

Residential & Commercial Irrigation International Market





TORO WATERSMART® SYSTEM SOLUTIONS

All the parts of an irrigation system (controller, valves, sprinklers) work together to ensure your customer's landscape is watered properly. Toro WaterSmart® products can be retrofitted or added to any system to provide more efficient use of water while maintaining healthy landscapes. Incorporate WaterSmart solutions throughout the whole system to ensure optimum water savings.



WHAT'S NEW IN IRRIGATION PRODUCTS

Tempus™. Discover.



SEE PAGE
101-104

Tempus™ and Tempus™PRO

Discover the value of your Time, Tempus™ and Tempus™PRO take care of the irrigation of your garden.

With these controllers it is possible to have the full control of your irrigation at any time and wherever you are.



Tempus™DC

The new Tempus™DC is the ideal controller to manage irrigation in areas without electricity. Bluetooth connectivity is integrated to allow intuitive programming.

The range includes two versions: with and without LCD screen.



Tempus™DC LCD

SEE PAGE
93

TORO®



SPRAYS

Pages 7-42

LPS Series	9-12
570Z Series	13-16
Precision™ Series Spray Nozzles	17-24
Precision™ Series Rotating Nozzles	25-28
Precision™ Series H ₂ FLO™ Variable Radius Nozzles	29-30
MPR Plus Nozzles	31-32
TVAN Variable Arc Nozzles	33-34
Pressure-Compensating Flood Bubblers	35
500 Series Bubblers	35
Stream Spray Nozzles	36
Stream Bubbler Nozzles	36
Precision Check Valve	37
Spray Tools & Accessories	38
Super Funny Pipe®	39-40
Super Funny Pipe Swing Joints	41
Super Funny Pipe Fittings ccessories	42



ROTORS

Pages 43-72

Mini 8 Series	45-48
300 Series Stream Rotor®	49-52
T5 RapidSet® Series	53-56
T7 Series	57-60
640 Series	61-64
TS90 Series	65-68
690 Series	69-71
Rotor Accessories	72

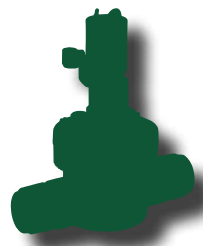

VALVES

Pages 73-92

EZ-Flo® Plus Series	75-76
TPV Series	77-78
264 Series	79-80
P150 Series	81-82
252 Series	83-84
P-220 Series	85-86
P-220S Scrubber Series	87-88
220 Brass Series	89-90
Quick Coupler Series	91
Valve Accessories	92



CONTROLLERS

Pages 93-116

TEMPUS DC™ Series	95-96
Electronic Tap Timer	97-98
DDC™ WP	99-100
TEMPUS™ Series	101-102
TEMPUS™ PRO Series	103-104
Lawn Master II	105-106
DDC™ Series	107-108
EVOLUTION® Series	109-110
TMC-424E Series	111-112
Custom Command™ Series	113-114
TDC Series Two-Wire System	115-116

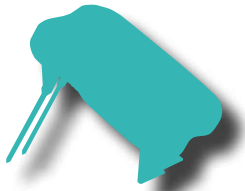

SENSORS & REMOTES

Pages 117-132

Precision™ Soil Sensor	119-122
Turf Guard®	123-124
Wireless ET Weather Sensor	125-128
Wireless RainSensor™	129
Wired RainSensor™	130
TFS Flow Sensors	131
EVOLUTION® Smart Connect® Remote	132



MICRO IRRIGATION FOR LANDSCAPE

Pages 133-156

Neptune PC - Woodland Brown	135
Neptune HW - Woodland Brown	136
Drip In® PC Brown	137
Drip In PC Camouflage Green	138
Drip In PC ROOTGUARD®	139-140
S-Drip Brown	141
Polyethylene Hose	142
NGE® AL	143
White Spider	144
Euro Plus	145
Euro Key	146
Fogger	147
Bubbler™	147
Varis™ & Varistake™	148
Trickler	148
Varijet / Accessories	149
Screen In-line filters	150
M Series filters	150
S and M Series filters	151
XD Series filters	152
Universal Valve Boxes	153-154
Pressure Regulators	155
Drip Line and PE Tube Fittings	156



CENTRAL CONTROL

Pages 157-164

Tricomm® Sustum	159-160
Sentinel® Central Control	161-162
National Support Network (NSN®)	163



RESOURCES

Pages 165-170

Customer Support	167
Formulas & Conversion Factors	168
Sprinkler Spacing & Winterization	169
Wire Sizing	170

SPRAYS

Whether you need a spray solution for turf lawns, slopes, medians, high traffic, or high wind locations, Toro® spray bodies provide the options you are looking for. Traditional MPR to high efficiency water management solutions, Toro nozzles provide reliable easy-to-use products with the latest in water saving technology.



TORO®



SPRAYS

Pages 7-42

LPS Series	9-12
570Z Series	13-16
Precision™ Series Spray Nozzles	17-24
Precision™ Series Rotating Nozzles	25-28
Precision™ Series H2FLO™ Variable Radius Nozzles	29-30
MPR Plus Spray Nozzles	31-32
TVAN Variable Arc Nozzles	33-34
Pressure-Compensating Flood Bubblers	35
500 Series Bubblers	35
Stream Spray Nozzles	36
Stream Bubbler Nozzles	36
Precision™ Check Valve	37
Spray Tools & Accessories	38
Super Funny Pipe®	39-40
Super Funny Pipe Swing Joints	41
Super Funny Pipe Fittings	42

The Toro® LPS Series meets the demand without sacrificing quality. These fixed sprays feature a durable, compact body with a pressure activated seal that minimizes flow-by during start-up and keeps debris away during retraction



LPS SERIES SPRAYS

FEATURES & BENEFITS

Pressure Activated Seal

Minimizes flow-by during pop-up and keeps debris away from stem during retraction.

Stainless Steel Retraction Spring

This heavy-duty spring ensures positive pop-down.

Easy Grip Top

Unique grip-and-turn adjustment from the top of the nozzle – wet or dry.

Removable Components

Nozzle, screen and internal components are easily removed for flushing and servicing.

Compatible With All 570Z Nozzles

Available with pre-installed Toro Variable Arc Nozzles (TVAN), Precision™ Series spray nozzles (Variable Radius) or Precision™ Series rotating nozzles



Check Valve
Options Available



OPTIONAL CHECK VALVE

The LPS sprinkler series has an optional check valve rated to hold back 2,1m of elevation change.

This helps to eliminate low head drainage and keeps the lines charged to lessen water hammer potential.



WATER MANAGEMENT

Available with Precision™ Series Nozzles and Precision™ Series Rotating Nozzles preinstalled.



SPECIFICATIONS

Operational

- Radius: 0,6-7,9m
- Operating pressure range: 1,4-3,5 Bar
- Recommended pressure for TVAN nozzles: 2,1 Bar
- Flow by: 0 at 0,7 Bar or greater
- Infinitely adjustable from 0° to 360°
- Top color-coded nozzles

PRN:

- Radius: 4,3m-7,9m
- Operating pressure range: 1,4-3,8 bar maximum: 5,2 bar
- Recommended pressure for rotating nozzles: 2,8-3,5 Bar
- Flow Rate: 0,6-13,9 LPM

Options

- LPSCV: Check Valve-Maintains up to 2,1 m elevation change

Dimensions

- Body diameter: 30mm
- Cap diameter: 41mm
- Inlet: ½" female-threaded

Warranty

- Two years

LPS SERIES MODEL LIST

Model	Description
LPS200	50mm (2") Pop-up w/o nozzle
LPS208	500mm (2") Pop-up w/TVAN8 installed
LPS210	50mm (2") Pop-up w/TVAN10 installed
LPS212	50mm (2") Pop-up w/TVAN12 installed
LPS215	50mm (2") Pop-up w/TVAN15 installed
LPS217	50mm (2") Pop-up w/TVAN17 installed
LPS400	100mm (4") Pop-up w/o nozzle
LPS408	100mm (4") Pop-up w/TVAN8 installed
LPS410	100mm (4") Pop-up w/TVAN10 installed
LPS412	100mm (4") Pop-up w/TVAN12 installed
LPS415	100mm (4") Pop-up w/TVAN15 installed
LPS417	100mm (4") Pop-up w/TVAN17 installed
53877	Multi-Stream PRN (Adjustable) PRN-TA
53878	Multi-Stream PRN (Full) PRN-TF
53892	100mm (4") LPS Spray w/ Variable Radius Precision™ Series Nozzle, Quarter Circle
53893	100mm (4") LPS Spray w/ Variable Radius Precision™ Series Nozzle, Half Circle
53894	100mm (4") LPS Spray w/ Variable Radius Precision™ Series Nozzle, Full Circle

Specifying Information—LPS Series

LPS X XX CV				
Base Model	Pop-Up Height	Nozzle		Optional
LPS	XX	XX		XXX
LPS—LPS Fixed Spray	2 — 2" (50mm) 4 — 4" (100mm)	00—Body Only* 08— 2,4m (8)* 10— 3,0m (10')	12— 3,7m (12') 15— 4,6m (15') 17— 5,2m (17')	CV — Check Valve
Example: A 100mm (4") Fixed-spray Sprinkler with a 3,0m (10') nozzle, would be specified as: LPS410				

*4" only

RUGGED – FLEXIBLE – VERSATILE – RELIABLE: Toro® 570Z Series spray heads provide a durable solution for residential and commercial contractors to satisfy all installation and retrofit requirements. In combination with Toro spray and rotating nozzles, 570Z Series spray heads can be configured in hundreds of combinations and present an unparalleled range of flexibility. Available in 2", 3", 4", 6" and 12" models with both bottom and side inlet thread options, Toro 570Z Series spray heads are further available with patented in-stem X-Flow® Technology and Pressure Regulating water-saving features. Trusted for over 25 years, Toro's 570Z Series spray heads are the ideal choice.



570Z SERIES SPRAYS

FEATURES & BENEFITS

Zero Flush Wiper Seal

The elimination of flushing on pop-up allows for more sprinklers to be installed per zone.

Patented X-Flow® Technology

The X-Flow in-stem flow shut-off device is built into the riser and restricts water loss by 99% should the nozzle be removed or damaged. The exclusive X-Flow device greatly reduces water waste, landscape erosion, and wet hardscape safety concerns. Furthermore, X-Flow allows for 'dry' nozzle and filter replacement or system maintenance while the system is running.

One-Piece Check Valve (570CV)

Pre-installed from the factory or easily installed in the field, Toro's one-piece check valve prevents low-head drainage on elevation changes of up to 3 m.

Ratcheting Riser

Quick and precise arc adjustment on all pop-up models.

Additional Features

- ✓ Corrosion-resistant stainless steel retraction spring
- ✓ All models shipped with installed flush plug

Options Available

- ✓ Serviceable Check Valve (570CV) prevents low-head drainage on elevation changes of up to 3 m (not compatible with Side Inlet models)
- ✓ Replacement Zero-Flush seal (570SEAL)
- ✓ Effluent water indicators:
 - Effluent Shrub Adapter (102-0563)-
 - Effluent snap-on cap cover (89-9752)
 - Effluent Cap with seal (102-1211)
- ✓ 6" (150mm) Riser Extender (570-6X)
- ✓ 6" (150mm) Stationary Riser (570-SR-6) [1/2" male-threaded inlet]
- ✓ 18" (450mm) Stationary Riser (570-SR-18) [1/2" male-threaded inlet]
- ✓ Riser Pull-up Tool (89-6395)
- ✓ Nozzle Adjustment Key (89-7350)



Effluent Options Available



Check Valve Options Available



Enhanced Zero Flush Seal

No Water Wasted at System Start

System start up is a critical time when water waste can occur. The Toro 570Z Series spray head's wiper seal is pressure-activated and prevents flow-by at start up, meaning no water is wasted and more heads can be installed on the same line.

Patented X-Flow® Shut-off Device

X-Flow® Technology Cuts Off Water Waste

Up to 151 liters of water per minute can escape through a spray head that has a missing or damaged nozzle. This wasted water can lead to landscape erosion, property damage, or unsafe conditions due to wet hardscapes. The patented X-Flow device is factory-installed in the riser and holds back over 99% of the water that would otherwise be wasted in cases where the nozzle has been compromised through unintentional accidents or vandalism. Furthermore, X-Flow Technology allows for spray head maintenance or component replacement without the need to turn off the system.



Without X-Flow



With X-Flow

Pressure Regulator

Reliability thanks to Built-in Pressure Regulation

Toro's factory-installed pressure regulator eliminates water misting and fogging at the nozzle that can lead to rapid evaporation or water being blown away from the intended irrigation area. From the first to the last head, the in-stem pressure regulator provides a steady outlet pressure of 2,1 bar and consistent spray head performance across the zone.

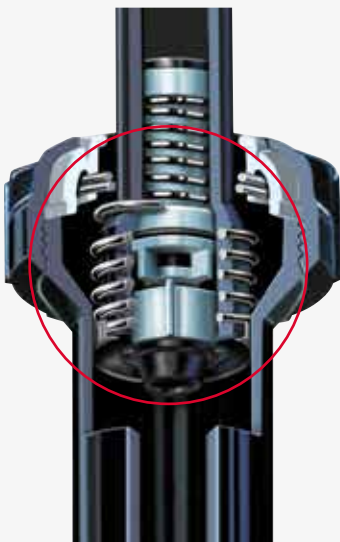

Without Pressure Regulation



With Pressure Regulation

SPECIFICATIONS

Operational

- Radius: 0,6 – 7,9 m
- Operating pressure range: 1,4-5,2 Bar (1,0-5,2 Bar for Low Pressure models)
- Recommended operating pressure for spray nozzles: 2,1 Bar
- Recommended operating pressure for rotating nozzles: 2,8-3,5 Bar
- Flow rate: 0,2 – 17,0 l/min

Dimensions

- Body diameter:
 - 35mm (13/8") on 2P, 3P, 4P, 6P and 6P SI models
 - 41mm (15/8") on 12P
 - 45mm (1 3/4") on 12P SI
- Cap diameter: 50mm (2")
- Inlet: 1/2" female-threaded
- Side inlet: 4 3/4" from top of sprinkler to center of side inlet

Warranty

- Five years on 570ZPR and 570ZPRX models
- Two years on 570Z, 570ZLP and 570ZXF



570Z & 570ZLP

570S

Shrub Adapter

570Z-2P Spray Head

570Z-2LP 2" Spray Head, Low Pressure

570Z-3P 3" Spray Head

570Z-3LP 3" Spray Head, Low Pressure

570Z-4P 4" Spray Head

570Z-4LP 4" Spray Head, Low Pressure

570Z-6P 6" Spray Head

570Z-6LP 6" Spray Head, Low Pressure

570Z-6SI 6" Spray Head, Side Inlet body

570Z-6LPSI 6" Spray Head, Low Pressure, Side Inlet body

570Z-12P 12" Spray Head

570Z-12LP 12" Spray Head, Low Pressure

570Z-12SI 12" Spray Head, Side Inlet body

570Z-12LPSI 12" Spray Head, Low Pressure, Side Inlet body

570Z-4P-COM 4" Spray Head with Check Valve

570Z-6P-COM 6" Spray Head with Check Valve

570Z-12P-COM 12" Spray Head with Check Valve



570ZXF

570S-XF

Shrub Adapter with X-Flow

570Z-4P-XF

4" XF Spray Head

570Z-6P-XF

6" XF Spray Head

570Z-6SI-XF

6" XF Spray Head, Side Inlet Body

570Z-12P-XF

12" XF Spray Head

570Z-12SI-XF

12" XF Spray Head, Side Inlet Body

570Z-4P-XFCOM

4" XF Spray Head with Check Valve

570Z-6P-XFCOM

6" XF Spray Head with Check Valve

570Z-12P-XFCOM

12" XF Spray Head with Check Valve

Note:all w/o nozzle



570ZPR

570S-PR

PR Shrub Adapter

570Z-4P-PR

4" PR Spray Head

570Z-6P-PR

6" PR Spray Head

570Z-12P-PR

12" PR Spray Head

570Z-4P-PRCOM

4" PR Spray Head with Check Valve

570Z-6P-PRCOM

6" PR Spray Head with Check Valve

570Z-12P-PRCOM

12" PR Spray Head with Check Valve



570ZPRX

570S-PRX

PRX Shrub Adapter

570Z-4P-PRX

4" PRX Spray Head

570Z-6P-PRX

6" PRX Spray Head

570Z-6SI-PRX

6" PRX Spray Head, Side Inlet Body

570Z-12P-PRX

12" PRX Spray Head

570Z-12SI-PRX

12" PRX Spray Head, Side Inlet Body

570Z-4P-PRXCOM

4" PRX Spray Head with Check Valve

570Z-6P-PRXCOM

6" PRX Spray Head with Check Valve

570Z-12P-PRXCOM

12" PRX Spray Head with Check Valve



Specifying Information—570Z Series

570X-XXXXX-XXXXXXX

Base Model	Pop-Up Height	Spring and Inlet	Optional	Optional	Optional
570X	XX	XXX-	XXX	XXX	X
S — Shrub Z — Lawn Pop-up	2 — 2" (50mm) 3 — 3" (75mm) 4 — 4" (100mm) 6 — 6" (150mm) 12 — 12" (300mm)	P — Standard LP — Low Pressure SI — Std. Side Inlet* LPSI — Low Pressure SI	XF — X-Flow® Technology PR — Pressure Regulator PRX — Pressure Regulator with XF	COM — Check Valve**	E — Effluent

Example: A 570Z PRX Series Sprinkler with a 6" pop-up height, side inlet would be specified as: **570Z-6SI-PRX**

*Available for 6" and 12" models. **Available with non-side inlet models.

Toro® Precision™ Series Spray Nozzles are the most efficient spray nozzles available and feature proprietary H²O Chip Technology. With a precipitation rate of 22mm per hour Precision™ Series Spray Nozzles help irrigation professionals better manage water usage, eliminate runoff, and reduce their customers' water bills. These nozzles are available in a wide variety of arcs and radii, as well as Toro (male) and female-threaded bodies, making them ideal for large scale installations and retrofits. In addition, the best-in-class* Precision™ Series Spray nozzles are available with factory-installed Pressure Compensating Discs (PCD).

The Toro logo is the word "TORO" in a white, bold, sans-serif font, set against a red rounded rectangular background. The nozzle in the foreground is a black, cylindrical spray nozzle with a red top cap. The top cap has a circular pattern of small holes and the word "TORO" printed on it. Water is spraying out from the nozzle in a fine mist. The background is a blurred green lawn.

TORO

**Laboratory and third party independent field testing show efficiency to be 15-20% higher than competitive nozzles at 4,5m or less.*

PRECISION™ SERIES SPRAY NOZZLES

FEATURES & BENEFITS

Patented H²O Chip Technology

Each nozzle contains one or more H²O chips that create a high frequency oscillating stream and deliver a precipitation rate of 22mm per hour – an industry first – while using up to 35% less water than a standard MPR nozzle.

Pressure-Compensating Versions Available

At a fraction of the cost of a pressure-regulating spray head, pressure-compensating Precision™ Series Spray Nozzles maintain a 22mm per hour precipitation rate and minimize misting and water waste that results from higher pressure systems.

Design and Retrofit Effectiveness

The lower flow rate of Precision™ Series Spray Nozzles maximizes design efficiency and helps reduce overall material costs based on the need for fewer valves and controller stations.

Third-Party Performance Validation

Precision™ Series Spray Nozzles* have been tested and validated in the field and at the Center for Irrigation Technology (CIT).

* non-PCD models only

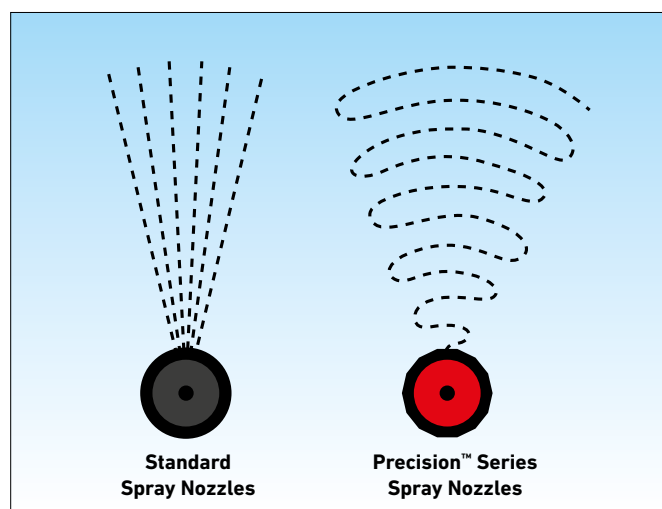

Patented H²O Chip Technology Delivers Improved Uniformity
 Water enters a specially designed chamber within the H²O Chip where the water expands and collapses, creating an oscillating effect. Consistent-sized water droplets exit the Chip in the designed arc pattern and radius with clean edge definition, class-leading distribution uniformity, and reduced water usage.

Additional Features

- ✓ Specialty Arcs available (60°, 120°, 150°, 210°, 240°)
- ✓ Radius reduction capability of 25%
- ✓ Matched precipitation rate after radius adjustment
- ✓ Screen attached to nozzle for easy insertion into the spray body



Male-threaded Model



Female-threaded Model

Pressure Compensating Disc (PCD)
 The elastomeric PCD adjusts in response to changes in inlet pressure to maintain optimal nozzle performance. Recommended for use on systems operating above 2.8 Bar, PCD models can easily be identified by the red Toro lettering across the top of the nozzle.





25mm Per Hour Matched Precipitation & One-For-One Retrofit

Perfect when upgrading conventional, higher flow spray nozzles... Look for the "0" stamped on top of the nozzle.

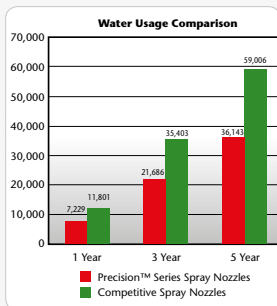

Higher Overall Irrigation Efficiency From 1,5-4,6m

Precision™ Series Spray nozzles perform more like a small rotor. The H²O Chip enables the nozzles to achieve distances of throw equivalent to those of conventional spray nozzles – but with one-third less flow and higher overall irrigation efficiency.



Water Use Reduction While Minimizing Run-Off & Water Waste

Precision™ Series Spray Nozzles have proven to save water in the field while reducing unnecessary overspray, wasteful run-off and evaporation.



Nozzle Selection Second To None

Available in male and female threaded models with a radius between 1,5 and 4,6m and the nozzle tops are color-coded to indicate the specific radius.

Available in models with 9 different arcs between 60° and 360°, and specialty arcs such as right and left corners and center strips. All Precision™ nozzles can be used with operating pressures of between 1,4 and 3,5 Bar

SPECIFICATIONS

Operational

- Radius: 1,5-4,6 m
- Operating pressure range: 2,8-5,2 Bar
- Recommended operating pressure:
 - Non-Pressure Compensating: 2,0 Bar
 - Pressure Compensating - 3,5 Bar
- Flow Rate: 0,15-9,6 l/m
- Nozzle trajectory:
 - 1,5m (5'): 5°
 - 2,4m (8'): 10°
 - 3,0m (10'): 15°
 - 3,7m (12'): 20°
 - 4,6m (15'): 27°
 - Corner and Side Strips: 20°

Warranty

- Two years



Laboratory and third party independent field testing show efficiency to be 15-20% higher than competitive nozzles at 4,6m or less.

PRECISION™ SERIES SPRAY NOZZLE MODEL LIST

1,5M (5') NOZZLE (RED)			2,4M (8') NOZZLE (GREEN)		
Male	Female	Pattern	Male	Female	Pattern
O-T-5-60	O-5-60	60° Arc	O-T-8-60	O-8-60	60° Arc
O-T-5-Q	O-5-Q	90° Arc	O-T-8-Q	O-8-Q	90° Arc
O-T-5-T	O-5-T	120° Arc	O-T-8-T	O-8-T	120° Arc
O-T-5-150	O-5-150	150° Arc	O-T-8-150	O-8-150	150° Arc
O-T-5-H	O-5-H	180° Arc	O-T-8-H	O-8-H	180° Arc
O-T-5-210	O-5-210	210° Arc	O-T-8-210	O-8-210	210° Arc
O-T-5-TT	O-5-TT	240° Arc	O-T-8-TT	O-8-TT	240° Arc
O-T-5-TQ	O-5-TQ	270° Arc	O-T-8-TQ	O-8-TQ	270° Arc
O-T-5-F	O-5-F	360° Arc	O-T-8-F	O-8-F	360° Arc
3,0M (10') NOZZLE (BLUE)			3,7M (12') NOZZLE (BROWN)		
O-T-10-60	O-10-60	60° Arc	O-T-12-60	O-12-60	60° Arc
O-T-10-Q	O-10-Q	90° Arc	O-T-12-Q	O-12-Q	90° Arc
O-T-10-T	O-10-T	120° Arc	O-T-12-T	O-12-T	120° Arc
O-T-10-150	O-10-150	150° Arc	O-T-12-150	O-12-150	150° Arc
O-T-10-H	O-10-H	180° Arc	O-T-12-H	O-12-H	180° Arc
O-T-10-210	O-10-210	210° Arc	O-T-12-210	O-12-210	210° Arc
O-T-10-TT	O-10-TT	240° Arc	O-T-12-TT	O-12-TT	240° Arc
O-T-10-TQ	O-10-TQ	270° Arc	O-T-12-TQ	O-12-TQ	270° Arc
O-T-10-F	O-10-F	360° Arc	O-T-12-F	O-12-F	360° Arc
4,6M (15') NOZZLE (BLACK)			SPECIAL PATTERNS (GREY)		
O-T-15-60	O-15-60	60° Arc	Male	Female	
O-T-15-Q	O-15-Q	90° Arc	O-T-4X9-RCS	O-4X9-RCS	Right Corner
O-T-15-T	O-15-T	120° Arc	O-T-4X9-LCS	O-4X9-LCS	Left Corner
O-T-15-150	O-15-150	150° Arc	O-T-4X18-SST	O-4X18-SST	Side Strip
O-T-15-H	O-15-H	180° Arc	O-T-4X15-RCS	O-4X15-RCS	Right Corner
O-T-15-210	O-15-210	210° Arc	O-T-4X15-LCS	O-4X15-LCS	Left Corner
O-T-15-TT	O-15-TT	240° Arc	O-T-4X30-SST	O-4X30-SST	Side Strip
O-T-15-TQ	O-15-TQ	270° Arc			
O-T-15-F	O-15-F	360° Arc			

PRESSURE-COMPENSATING

PRECISION™ SERIES SPRAY NOZZLE MODEL LIST

1,5M (5') NOZZLE (RED)			2,4M (8') NOZZLE (GREEN)		
Male	Female	Pattern	Male	Female	Pattern
O-T-5-60P	O-5-60P	60° Arc	O-T-8-60P	O-8-60P	60° Arc
O-T-5-QP	O-5-QP	90° Arc	O-T-8-QP	O-8-QP	90° Arc
O-T-5-TP	O-5-TP	120° Arc	O-T-8-TP	O-8-TP	120° Arc
O-T-5-150P	O-5-150P	150° Arc	O-T-8-150P	O-8-150P	150° Arc
O-T-5-HP	O-5-HP	18° Arc	O-T-8-HP	O-8-HP	18° Arc
O-T-5-210P	O-5-210P	210° Arc	O-T-8-210P	O-8-210P	210° Arc
O-T-5-TTP	O-5-TTP	240° Arc	O-T-8-TTP	O-8-TTP	240° Arc
O-T-5-TQP	O-5-TQP	270° Arc	O-T-8-TQP	O-8-TQP	270° Arc
O-T-5-FP	O-5-FP	360° Arc	O-T-8-FP	O-8-FP	360° Arc
3,0M (10') NOZZLE (BLUE)			3,7M (12') NOZZLE (BROWN)		
O-T-10-60P	O-10-60P	60° Arc	O-T-12-60P	O-12-60P	60° Arc
O-T-10-QP	O-10-QP	90° Arc	O-T-12-QP	O-12-QP	90° Arc
O-T-10-TP	O-10-TP	120° Arc	O-T-12-TP	O-12-TP	120° Arc
O-T-	O-	150° Arc	O-T-12-150P	O-12-150P	150° Arc
O-T-10-150P	O-10-150P	18° Arc	O-T-12-HP	O-12-HP	18° Arc
O-T-10-HP	O-10-HP	210° Arc	O-T-12-210P	O-12-210P	210° Arc
O-T-	O-	240° Arc	O-T-12-TTP	O-12-TTP	240° Arc
O-T-10-210P	O-10-210P	270° Arc	O-T-12-TQP	O-12-TQP	270° Arc
O-T-10-TTP	O-10-TTP	360° Arc	O-T-12-FP	O-12-FP	360° Arc
O-T-10-TQP	O-10-TQP				
O-T-10-FP	O-10-FP				
4,6M (15') NOZZLE (BLACK)			SPECIAL PATTERNS (GREY)		
O-T-15-60P	O-15-60P	60° Arc	Male	Female	
O-T-15-QP	O-15-QP	90° Arc	O-T-4X9-RCSP	O-4X9-RCSP	Right Corner
O-T-15-TP	O-15-TP	120° Arc	O-T-4X9-LCSP	O-4X9-LCSP	Left Corner
O-T-	O-	150° Arc	O-T-4X18-SSTP	O-4X18-SSTP	Side Strip
O-T-15-150P	O-15-150P	18° Arc	O-T-4X15-RCSP	O-4X15-RCSP	Right Corner
O-T-15-HP	O-15-HP	210° Arc	O-T-4X15-LCSP	O-4X15-LCSP	Left Corner
O-T-	O-	240° Arc	O-T-4X30-SSTP	O-4X30-SSTP	Side Strip
O-T-15-210P	O-15-210P	270° Arc			
O-T-15-TTP	O-15-TTP	360° Arc			
O-T-15-TQP	O-15-TQP				
O-T-15-FP	O-15-FP				

Specifying Information-Precision™ Series Spray Nozzles

O-X-XXXX-XXXX-P					
Nozzle	Thread	Radius	Arc	PCD	
O	X	XXXX	XXXX	P	
O—25mm (1") Per Hour	T—Toro Male-Threaded Nozzle Blank—Female Threaded Nozzle	5— 1,5m (5') 8— 2,4m (8') 10— 3,0m (10') 12— 3,7m (12') 15— 4,6m (15')	4X15 — 1,2mX4,6m (4'X15') (PCD Models only) 4X30 — 1,2mX9,1m (4'X30') (PCD Models only) 4X9 — 1,2mX2,7m (4'X9') 4X18 — 1,2mX5,5m (4'X18')	60 — 60°* Q — 90° T — 120° 150 — 150°* H — 180° 210 — 210°* TT — 240° TQ — 270° F — 360° -Full Circle LCS — Left Corner RCS — Right Corner SST — Side Strip	P—Pressure Compensating

Example: A female-threaded Precision™ Series Spray with a spray radius of 3,7m (12') and a 90° arc would be specified as: O-12-Q

Example 2: A male-threaded Pressure-Compensating Precision™ Series Spray with a spray radius of 3,0m (10') and a 180° arc would be specified as O-T-10-HP

*Not available with Pressure Compensation.



PERFORMANCE DATA PRESSURE COMPENSATING – PRECISION™ SERIES SPRAY NOZZLES

Arc	model # (0-XX-XX)	Press. (Bar)	Flow (LPM)	Radius (m)	Precip. Rate ■ (cm./hr)	Precip. Rate ▲ (cm./hr)	model # (0-XX-XX)	Press. (Bar)	Flow (LPM)	Radius (m)	Precip. Rate ■ (cm./hr)	Precip. Rate ▲ (cm./hr)	model # (0-XX-XX)	Press. (Bar)	Flow (LPM)	Radius (m)	Precip. Rate ■ (cm./hr)	Precip. Rate ▲ (cm./hr)
60°	5-60P	2,8	0,26	1,83	3,05	3,56	8-60P	2,8	0,42	2,29	2,79	3,30	10-60P	2,8	0,61	2,90	2,54	3,05
		3,4	0,26	1,68	3,30	3,81		3,4	0,42	2,29	3,05	3,30		3,4	0,68	3,20	2,54	2,79
		4,1	0,26	1,83	2,54	3,05		4,1	0,45	2,29	3,30	3,56		4,1	0,76	3,36	2,54	2,79
		4,8	0,30	1,98	2,54	3,05		4,8	0,53	2,44	3,05	3,56		4,8	0,83	3,36	2,79	3,05
90°	5-QP	2,8	0,23	1,40	2,54	3,05	8-QP	2,8	0,53	2,14	2,79	3,30	10-QP	2,8	0,98	2,90	2,54	2,79
		3,4	0,30	1,56	3,05	3,56		3,4	0,64	2,35	3,05	3,30		3,4	1,06	3,05	2,79	3,05
		4,1	0,34	1,71	3,30	3,81		4,1	0,76	2,56	3,05	3,56		4,1	1,10	3,20	2,79	3,30
		4,8	0,42	1,89	3,81	4,32		4,8	0,87	2,78	3,30	3,56		4,8	1,17	3,39	3,05	3,56
120°	5-TP	2,8	0,26	1,34	2,54	2,79	8-TP	2,8	0,76	2,32	2,54	3,05	10-TP	2,8	1,17	2,90	2,54	2,79
		3,4	0,42	1,49	3,30	3,81		3,4	0,91	2,44	2,79	3,30		3,4	1,36	3,05	2,79	3,05
		4,1	0,57	1,68	4,32	5,08		4,1	1,02	2,59	3,05	3,56		4,1	1,55	3,20	3,05	3,56
		4,8	0,72	1,83	5,08	6,10		4,8	1,17	2,71	3,30	3,81		4,8	1,74	3,36	3,30	3,81
150°	5-150P	2,8	0,53	1,83	2,29	2,54	8-150P	2,8	1,21	2,44	2,79	3,30	10-150P	2,8	1,78	2,90	3,05	3,56
		3,4	0,53	1,83	2,29	2,54		3,4	1,21	2,59	2,54	3,05		3,4	1,85	3,05	2,79	3,30
		4,1	0,53	1,83	2,29	2,54		4,1	1,21	2,44	2,79	3,30		4,1	1,93	3,05	3,05	3,56
		4,8	0,53	1,83	2,29	2,54		4,8	1,21	2,44	2,79	3,30		4,8	2,01	3,20	2,79	3,30
180°	5-HP	2,8	0,38	1,34	2,54	3,05	8-HP	2,8	0,98	2,14	2,54	3,05	10-HP	2,8	1,82	2,96	2,54	2,79
		3,4	0,49	1,49	2,79	3,30		3,4	1,25	2,32	2,79	3,30		3,4	2,01	3,08	2,79	3,05
		4,1	0,61	1,65	3,30	3,81		4,1	1,48	2,47	3,05	3,56		4,1	2,16	3,17	2,79	3,30
		4,8	0,72	1,83	3,56	4,06		4,8	1,74	2,65	3,30	3,81		4,8	2,35	3,29	3,05	3,56
210°	5-210P	2,8	0,61	1,53	2,79	3,05	8-210P	2,8	1,29	2,44	2,29	2,54	10-210P	2,8	2,16	2,90	2,79	3,05
		3,4	0,68	1,68	2,54	2,79		3,4	1,44	2,44	2,54	2,79		3,4	2,42	3,05	2,79	3,05
		4,1	0,76	1,83	2,29	2,79		4,1	1,59	2,44	2,79	3,30		4,1	2,65	3,05	3,05	3,30
		4,8	0,79	1,83	2,54	2,79		4,8	1,70	2,44	3,05	3,30		4,8	2,84	3,05	3,05	3,56
240°	5-TTP	2,8	0,53	1,31	2,79	3,30	8-TTP	2,8	1,29	2,14	2,54	2,79	10-TTP	2,8	2,38	2,93	2,54	2,79
		3,4	0,76	1,49	3,30	3,81		3,4	1,63	2,38	2,79	3,05		3,4	2,65	3,02	2,79	3,05
		4,1	0,95	1,65	3,56	4,32		4,1	1,97	2,59	3,05	3,56		4,1	2,91	3,14	2,79	3,30
		4,8	1,17	1,83	4,06	4,57		4,8	2,31	2,84	3,30	3,81		4,8	3,18	3,23	3,05	3,56
270°	5-TQP	2,8	0,57	1,31	2,54	3,05	8-TQP	2,8	1,55	2,20	2,54	2,79	10-TQP	2,8	2,69	2,90	2,54	2,79
		3,4	0,79	1,49	3,05	3,56		3,4	1,82	2,41	2,79	3,05		3,4	2,91	3,02	2,54	3,05
		4,1	0,98	1,71	3,56	4,06		4,1	2,08	2,62	3,05	3,56		4,1	3,10	3,14	2,79	3,05
		4,8	1,21	1,89	3,81	4,32		4,8	2,35	2,84	3,30	3,81		4,8	3,33	3,26	2,79	3,30
360°	5-FP	2,8	0,64	1,22	2,54	3,05	8-FP	2,8	2,08	2,14	2,79	3,05	10-FP	2,8	3,60	2,93	2,54	2,79
		3,4	0,91	1,46	2,79	3,30		3,4	2,46	2,29	2,79	3,05		3,4	4,01	3,05	2,79	3,05
		4,1	1,17	1,68	3,05	3,56		4,1	2,80	2,44	2,79	3,30		4,1	4,39	3,20	2,79	3,30
		4,8	1,44	1,92	3,30	3,81		4,8	3,18	2,59	2,79	3,30		4,8	4,81	3,32	3,05	3,56

5 Radii Available in Toro Male and Female Threads

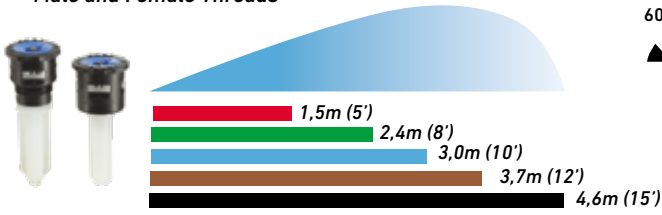

9 Arcs Plus Side and Corner Strips Available

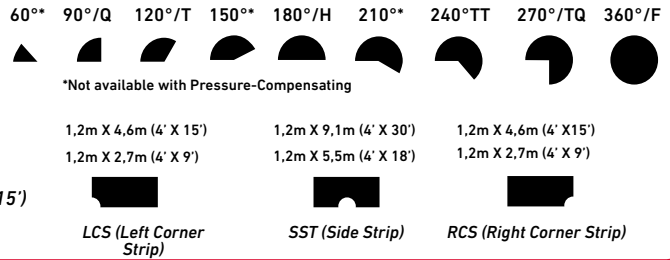

PERFORMANCE DATA PRESSURE COMPENSATING – PRECISION™ SERIES SPRAY NOZZLES

Arc	model # (O-XX-XX)	Press. (Bar)	Flow (LPM)	Radius (m)	Precip. Rate (cm./hr) ■	Precip. Rate (cm./hr) ▲	model # (O-XX-XX)	Press. (Bar)	Flow (LPM)	Radius (m)	Precip. Rate (cm./hr) ■	Precip. Rate (cm./hr) ▲	Arc	Press. (Bar)	Flow (LPM)	Radius (m)	Precip. Rate (cm./hr) ■	Precip. Rate (cm./hr) ▲
60°	12-60P	2,8	1,14	3,97	2,54	3,05	15-60P	2,8	1,36	4,27	2,79	3,05	4X30 SSTP	2,8	2,35	1,2x8,5	2,5	2,79
		3,4	1,14	3,97	2,54	3,05		3,4	1,55	4,58	2,54	3,05		3,4	2,46	1,2x9,1	2,5	3,05
		4,1	1,14	3,97	2,54	3,05		4,1	1,70	4,58	2,79	3,30		4,1	2,54	1,2x9,1	2,8	3,30
		4,8	1,14	3,97	2,54	3,05		4,8	1,82	4,58	3,05	3,56		4,8	2,65	1,2x9,1	2,8	3,30
90°	12-QP	2,8	1,29	3,66	2,54	3,05	15-QP	2,8	2,01	4,33	2,54	3,05	4X15 LCSP	2,8	1,21	1,2x4,5	2,5	3,05
		3,4	1,48	3,72	2,79	3,30		3,4	2,23	4,42	2,79	3,05		3,4	1,25	1,2x4,5	2,8	3,05
		4,1	1,63	3,81	3,05	3,30		4,1	2,42	4,51	2,79	3,30		4,1	1,29	1,2x4,5	2,8	3,30
120°	12-TP	2,8	1,74	3,51	2,54	3,05	15-TP	2,8	2,73	4,36	2,54	3,05	4X15 RCSP	2,8	1,21	1,2x4,5	2,5	3,05
		3,4	1,89	3,60	2,54	3,05		3,4	2,91	4,51	2,54	3,05		3,4	1,25	1,2x4,5	2,8	3,05
		4,1	2,04	3,66	2,79	3,30		4,1	3,10	4,64	2,79	3,05		4,1	1,29	1,2x4,5	2,8	3,30
150°	12-150P	2,8	2,23	3,66	2,54	2,79	15-150P	2,8	3,52	4,27	2,79	3,30	4X18 SSTP	2,8	1,21	1,2x4,5	2,5	3,05
		3,4	2,50	3,51	3,05	3,30		3,4	3,94	4,42	3,05	3,30		3,4	1,25	1,2x4,5	2,8	3,05
		4,1	2,73	3,66	3,05	3,30		4,1	4,31	4,42	3,30	3,81		4,1	1,29	1,2x4,5	2,8	3,30
180°	12-HP	2,8	2,65	3,51	2,54	3,05	15-HP	2,8	4,16	4,42	2,54	3,05	4X9 LCSP	2,8	1,36	1,2x5,5	2,5	2,79
		3,4	2,84	3,60	2,54	3,05		3,4	4,54	4,36	2,79	3,05		3,4	1,40	1,2x5,5	2,5	3,05
		4,1	3,03	3,72	2,79	3,05		4,1	4,88	4,27	2,79	3,30		4,1	1,44	1,2x5,5	2,5	3,05
		4,8	3,22	3,81	2,79	3,05		4,8	5,26	4,21	3,05	3,30		4,8	1,48	1,2x5,5	2,5	3,05
210°	12-210P	2,8	3,26	3,36	3,05	3,56	15-210P	2,8	4,66	4,27	2,54	3,05	4X9 RCSP	2,8	0,68	1,2x2,7	2,5	2,79
		3,4	3,63	3,51	3,05	3,56		3,4	5,45	4,27	3,05	3,56		3,4	0,72	1,2x2,7	2,8	3,05
		4,1	3,97	3,66	3,05	3,56		4,1	5,90	4,27	3,30	3,81		4,1	0,76	1,2x2,7	2,8	3,05
		4,8	4,28	3,66	3,30	3,81		4,8	6,43	4,58	3,05	3,56		4,8	0,79	1,2x2,7	3,0	3,30
240°	12-TTP	2,8	3,41	3,48	2,54	3,05	15-TTP	2,8	5,49	4,42	2,54	3,05	4X9 RCSP	2,8	0,68	1,2x2,7	2,5	3,05
		3,4	3,90	3,51	2,79	3,30		3,4	5,94	4,51	2,54	3,05		3,4	0,72	1,2x2,7	2,8	3,05
		4,1	4,39	3,51	3,05	3,30		4,1	6,36	4,58	2,79	3,05		4,1	0,76	1,2x2,7	2,8	3,05
		4,8	4,88	3,54	3,05	3,56		4,8	6,81	4,67	2,79	3,30		4,8	0,79	1,2x2,7	3,0	3,30
270°	12-TQP	2,8	3,97	3,48	2,54	3,05	15-TQP	2,8	6,06	4,27	2,29	2,54	4X9 RCSP	2,8	0,68	1,2x2,7	2,5	3,05
		3,4	4,31	3,57	2,54	3,05		3,4	6,43	4,39	2,54	2,79		3,4	0,72	1,2x2,7	2,8	3,05
		4,1	4,66	3,66	2,79	3,30		4,1	6,81	4,51	2,54	3,05		4,1	0,76	1,2x2,7	2,8	3,05
		4,8	5,00	3,75	2,79	3,30		4,8	7,19	4,61	2,79	3,05		4,8	0,79	1,2x2,7	3,0	3,30
360°	12-FP	2,8	5,11	3,51	2,54	2,79	15-FP	2,8	8,33	4,42	2,54	3,05	4X9 RCSP	2,8	0,68	1,2x2,7	2,5	3,05
		3,4	5,64	3,60	2,54	3,05		3,4	8,93	4,51	2,54	3,05		3,4	0,72	1,2x2,7	2,8	3,05
		4,1	6,17	3,72	2,79	3,30		4,1	9,54	4,61	2,79	3,05		4,1	0,76	1,2x2,7	2,8	3,05
		4,8	6,70	3,81	2,79	3,30		4,8	10,14	4,70	2,79	3,30		4,8	0,79	1,2x2,7	3,0	3,30



PERFORMANCE DATA – PRECISION™ SERIES SPRAY NOZZLES

Arc	model # (O-XX-XX)	Press. (Bar)	Flow (LPM)	Radius (m)	Precip. Rate ■ (cm./hr.)	Precip. Rate ▲ (cm./hr.)	model # (O-XX-XX)	Press. (Bar)	Flow (LPM)	Radius (m)	Precip. Rate ■ (cm./hr.)	Precip. Rate ▲ (cm./hr.)	model # (O-XX-XX)	Press. (Bar)	Flow (LPM)	Radius (m)	Precip. Rate ■ (cm./hr.)	Precip. Rate ▲ (cm./hr.)
60°	5-60	1,4	0,15	1,43	2,54	3,05	8-60	1,4	0,38	2,32	2,54	3,05	10-60	1,4	0,61	2,90	2,54	3,05
		2,1	0,15	1,53	2,54	3,05		2,1	0,42	2,44	2,5	2,8		2,1	0,64	3,05	2,54	2,79
		2,8	0,15	1,53	2,54	3,05		2,8	0,45	2,47	2,8	3,0		2,8	0,68	3,05	2,54	3,05
		3,4	0,19	1,62	2,54	2,79		3,4	0,49	2,53	2,8	3,3		3,4	0,72	3,05	2,79	3,30
90°	5-Q	1,4	0,23	1,40	2,54	3,05	8-Q	1,4	0,53	2,14	2,8	3,3	10-Q	1,4	0,98	2,90	2,54	2,79
		2,1	0,23	1,53	2,54	2,79		2,1	0,64	2,44	2,5	2,8		2,1	0,87	3,05	2,54	3,05
		2,8	0,26	1,53	2,54	3,05		2,8	0,68	2,50	2,5	3,0		2,8	1,06	0,37	2,54	3,05
		3,4	0,26	1,53	2,54	3,05		3,4	0,68	2,56	2,5	2,8		3,4	1,06	0,40	2,54	3,05
120°	5-T	1,4	0,26	1,34	2,54	3,05	8-T	1,4	0,76	2,32	2,5	3,0	10-T	1,4	1,17	2,90	2,54	2,79
		2,1	0,34	1,53	2,54	3,05		2,1	0,83	2,44	2,5	2,8		2,1	1,29	3,05	2,54	2,79
		2,8	0,34	1,59	2,54	3,05		2,8	0,87	2,50	2,5	2,8		2,8	1,36	3,05	2,54	3,05
		3,4	0,38	1,65	2,54	2,79		3,4	0,91	2,53	2,5	2,8		3,4	1,40	3,05	2,79	3,05
150°	5-150	1,4	0,26	1,22	2,54	3,05	8-150	1,4	0,95	2,29	2,5	3,0	10-150	1,4	1,55	2,99	2,54	2,79
		2,1	0,42	1,53	2,54	3,05		2,1	1,02	2,44	2,5	2,8		2,1	1,63	3,05	2,54	2,79
		2,8	0,45	1,59	2,54	3,05		2,8	1,06	2,47	2,5	2,8		2,8	1,67	3,11	2,54	2,79
		3,4	0,49	1,65	2,54	3,05		3,4	1,10	2,50	2,5	3,0		3,4	1,74	3,17	2,54	2,79
180°	5-H	1,4	0,38	1,34	2,54	3,05	8-H	1,4	0,98	2,14	2,5	3,0	10-H	1,4	1,82	2,96	2,54	2,79
		2,1	0,49	1,53	2,54	3,05		2,1	1,25	2,44	2,5	2,8		2,1	1,93	3,05	2,54	2,79
		2,8	0,53	1,56	2,54	3,05		2,8	1,29	2,44	2,5	3,0		2,8	2,08	3,14	2,54	3,05
		3,4	0,53	1,59	2,54	2,79		3,4	1,29	2,44	2,5	3,0		3,4	2,12	3,17	2,54	3,05
210°	5-210	1,4	0,38	1,34	2,54	3,05	8-210	1,4	1,25	2,32	2,8	3,3	10-210	1,4	2,12	2,99	2,79	3,30
		2,1	0,57	1,59	2,79	3,05		2,1	1,36	2,44	2,8	3,3		2,1	2,20	3,05	2,79	3,30
		2,8	0,61	1,62	2,79	3,30		2,8	1,40	2,47	2,8	3,3		2,8	2,27	3,17	2,79	3,05
		3,4	0,64	1,68	2,79	3,30		3,4	1,44	2,50	2,8	3,3		3,4	2,35	3,20	2,79	3,30
240°	5-TT	1,4	0,53	1,31	2,79	3,30	8-TT	1,4	1,29	2,14	2,5	3,0	10-TT	1,4	2,38	2,93	2,54	2,79
		2,1	0,64	1,53	2,54	2,79		2,1	1,67	2,44	2,5	2,8		2,1	2,61	3,05	2,54	3,05
		2,8	0,72	1,53	2,79	3,05		2,8	1,74	2,44	2,5	3,0		2,8	2,76	3,14	2,54	2,79
		3,4	0,72	1,53	2,79	3,30		3,4	1,74	2,44	2,5	3,0		3,4	2,80	3,17	2,54	2,79
270°	5-TQ	1,4	0,57	1,31	2,54	3,05	8-TQ	1,4	1,55	2,20	2,5	2,8	10-TQ	1,4	2,69	2,90	2,54	2,79
		2,1	0,76	1,53	2,54	3,05		2,1	1,85	2,44	2,8	2,8		2,1	2,99	3,05	2,54	2,79
		2,8	0,79	1,53	2,79	3,05		2,8	2,04	2,44	2,8	3,0		2,8	3,18	3,14	2,54	2,79
		3,4	0,83	1,53	2,79	3,30		3,4	2,08	2,44	2,8	3,0		3,4	3,26	3,17	2,54	2,79
360°	5-F	1,4	0,64	1,22	2,54	3,05	8-F	1,4	2,08	2,14	2,8	3,0	10-F	1,4	3,60	2,93	2,54	2,79
		2,1	0,98	1,53	2,54	3,05		2,1	2,50	2,44	2,5	2,8		2,1	3,90	3,05	2,54	2,79
		2,8	0,98	1,53	2,54	3,05		2,8	2,57	2,44	2,5	3,0		2,8	4,09	3,14	2,54	2,79
		3,4	0,98	1,53	2,54	3,05		3,4	2,69	2,44	2,8	3,0		3,4	4,24	3,17	2,54	3,05

5 Radii Available in Toro Male and Female Threads

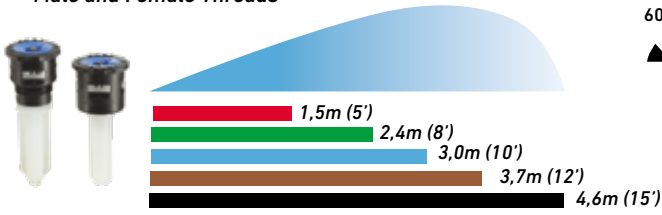

9 Arcs Plus Side and Corner Strips Available

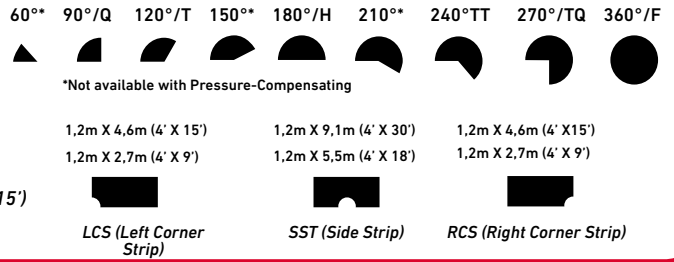

PERFORMANCE DATA – PRECISION™ SERIES SPRAY NOZZLES

Arc	model # (O-XX-XX)	Press. (Bar)	Flow (LPM)	Radius (m)	Precip. Rate (cm/hr) ■	Precip. Rate (cm/hr) ▲	model # (O-XX-XX)	Press. (Bar)	Flow (LPM)	Radius (m)	Precip. Rate (cm/hr) ■	Precip. Rate (cm/hr) ▲	Arc	Press. (Bar)	Flow (LPM)	Radius (m)	Precip. Rate (cm/hr) ■	Precip. Rate (cm/hr) ▲
60°	12-60	1,4	0,91	3,51	2,54	3,05	15-60	1,4	1,32	4,27	2,54	3,05	4X30 SST	1,4	2,35	1,2x8.5	2,54	2,79
		2,1	0,95	3,66	2,54	3,05		2,1	1,48	4,58	2,54	3,05		2,1	2,50	1,2x9.1	2,79	3,05
		2,8	0,98	3,69	2,54	3,05		2,8	1,51	4,61	2,54	3,05		2,8	2,54	1,2x9.1	2,79	3,05
		3,4	1,06	3,72	2,79	3,30		3,4	1,59	4,67	2,54	3,05		3,4	2,57	1,2x9.1	2,79	3,30
		3,4	1,06	3,72	2,79	3,30		3,4	1,59	4,67	2,54	3,05		3,4	2,57	1,2x9.1	2,79	3,30
90°	12-Q	1,4	1,29	3,66	2,54	3,05	15-Q	1,4	2,01	4,33	2,54	3,05	4X15 LCS	1,4	1,21	1,2x4.5	2,54	3,05
		2,1	1,40	3,69	2,54	2,79		2,1	2,20	4,58	2,54	2,79		2,1	1,25	1,2x4.5	2,79	3,05
		2,8	1,48	3,48	2,54	3,05		2,8	2,27	4,61	2,54	3,05		2,8	1,29	1,2x4.5	2,79	3,05
		3,4	1,48	3,66	2,54	2,79		3,4	2,31	4,67	2,54	3,05		3,4	1,29	1,2x4.5	2,79	3,30
120°	12-T	1,4	1,74	3,51	2,54	3,05	15-T	1,4	2,73	4,36	2,54	3,05	4X15 RCS	1,4	1,21	1,2x4.5	2,54	3,05
		2,1	1,85	3,66	2,54	2,79		2,1	2,91	4,58	2,54	2,79		2,1	1,25	1,2x4.5	2,79	3,05
		2,8	1,93	3,72	2,54	2,79		2,8	3,07	4,67	2,54	3,05		2,8	1,29	1,2x4.5	2,79	3,30
		3,4	1,97	3,75	2,54	2,79		3,4	3,10	4,70	2,54	3,05		3,4	1,29	1,2x4.5	2,79	3,30
150°	12-150	1,4	2,27	3,54	2,54	3,05	15-150	1,4	3,48	4,48	2,54	3,05	4X18 SST	1,4	1,36	1,2x5.5	2,54	2,79
		2,1	2,35	3,66	2,54	2,79		2,1	3,63	4,58	2,54	3,05		2,1	1,40	1,2x5.5	2,54	2,79
		2,8	2,38	3,72	2,54	2,79		2,8	3,79	4,64	2,54	3,05		2,8	1,44	1,2x5.5	2,54	3,05
		3,4	2,42	3,75	2,54	2,79		3,4	4,16	4,67	2,79	3,30		3,4	1,44	1,2x5.5	2,54	3,05
180°	12-H	1,4	2,65	3,51	2,54	3,05	15-H	1,4	4,16	4,42	2,54	3,05	4X9 LCS	1,4	0,68	1,2x2.7	2,54	3,05
		2,1	2,80	3,66	2,54	2,79		2,1	4,39	4,58	2,54	2,79		2,1	0,72	1,2x2.7	2,54	3,05
		2,8	2,99	3,75	2,54	3,05		2,8	4,73	4,70	2,54	3,05		2,8	0,76	1,2x2.7	2,79	3,05
		3,4	3,03	3,78	2,54	3,05		3,4	4,84	4,73	2,54	3,05		3,4	0,76	1,2x2.7	2,79	2,79
210°	12-210	1,4	2,88	3,54	2,79	3,30	15-210	1,4	4,35	4,42	2,79	3,05	4X9 RCS	1,4	0,68	1,2x2.7	2,54	3,05
		2,1	3,10	3,66	2,79	3,30		2,1	4,54	4,58	2,54	3,05		2,1	0,72	1,2x2.7	2,54	3,05
		2,8	3,18	3,75	2,79	3,05		2,8	4,92	4,73	2,54	3,05		2,8	0,76	1,2x2.7	2,79	3,05
		3,4	3,22	3,78	2,79	3,05		3,4	5,30	4,76	2,79	3,30		3,4	0,76	1,2x2.7	2,79	2,79
		3,4	3,22	3,78	2,79	3,05		3,4	5,30	4,76	2,79	3,30		3,4	0,76	1,2x2.7	2,79	2,79
240°	12-TT	1,4	3,41	3,48	2,54	3,05	15-TT	1,4	5,49	4,42	2,54	3,05	4X9 RCS	1,4	0,68	1,2x2.7	2,54	3,05
		2,1	3,75	3,66	2,54	2,79		2,1	5,83	4,58	2,54	2,79		2,1	0,72	1,2x2.7	2,54	3,05
		2,8	3,94	3,75	2,54	2,79		2,8	5,98	4,64	2,54	2,79		2,8	0,76	1,2x2.7	2,79	3,05
		3,4	3,97	3,78	2,54	2,79		3,4	6,09	4,67	2,54	2,79		3,4	0,76	1,2x2.7	2,79	3,05
270°	12-TQ	1,4	3,97	3,48	2,54	3,05	15-TQ	1,4	6,51	4,42	2,54	3,05	4X9 RCS	1,4	0,68	1,2x2.7	2,54	3,05
		2,1	4,35	3,66	2,54	3,05		2,1	6,74	4,58	2,54	2,79		2,1	0,72	1,2x2.7	2,54	3,05
		2,8	4,50	3,72	2,54	3,05		2,8	6,89	4,58	2,54	3,05		2,8	0,76	1,2x2.7	2,79	3,05
		3,4	4,62	3,75	2,54	3,05		3,4	7,19	4,67	2,54	3,05		3,4	0,76	1,2x2.7	2,79	3,05
360°	12-F	1,4	5,11	3,51	2,54	2,79	15-F	1,4	8,33	4,42	2,54	3,05	4X9 RCS	1,4	0,68	1,2x2.7	2,54	3,05
		2,1	5,60	3,66	2,54	2,79		2,1	8,74	4,58	2,54	2,79		2,1	0,72	1,2x2.7	2,54	3,05
		2,8	6,02	3,78	2,54	2,79		2,8	8,89	4,64	2,54	2,79		2,8	0,76	1,2x2.7	2,79	3,05
		3,4	6,06	3,81	2,54	2,79		3,4	9,08	4,67	2,54	2,79		3,4	0,76	1,2x2.7	2,79	3,05

Making use of the same patented gear drive technology found in Toro's world-leading Golf rotors, Toro® Precision™ Series Rotating Nozzles are powered by a planetary drive system that delivers a pattern of multiple wind resistant, multi-trajectory streams. The full circle and adjustable arc models deliver a radius range of 4,3 to 7,9 m with exceptional uniformity and close-in watering characteristics at a precipitation rate of 14mm per hour.



PRECISION™ SERIES ROTATING NOZZLES

FEATURES & BENEFITS

Consistent, Gear-Driven Performance

Precision™ Series Rotating Nozzles are uniquely powered by a patented planetary gear drive, variable stator and turbine. Unlike competing rotating nozzles, the Precision™ Series Rotating Nozzle's gear drive is not system pressure dependent and delivers consistent rotation speed and performance across a wide range of operating pressures. The entire drive system is protected by the factory-installed fine mesh filter screen.

Fewer Models

Two Toro-threaded models and two female-threaded models are all that are required to cover radius requirements of 4,3 to 7,9 meters and infinitely adjustable arcs between 45° and 270° or 360°. Fewer models allow for less inventory and more flexibility.

Matched Precipitation Rate

These nozzles deliver water more slowly and evenly than standard spray nozzles, which helps prevent runoff and water waste. Moreover, the 14mm per hour precipitation rate better positions users to meet watering window requirements than competing rotating nozzles.

EZ ARC™ Visual Arc Indicators

Toro Precision™ Series Rotating Nozzles are the only rotating nozzles available that allow the user to dial in the nozzle's arc setting before installation. Further, the nozzle features a right edge call-out on adjustable models that assists in quick and effective installations.

Additional Features

- ✓ Maximum trajectory height of 20° to help fight wind
- ✓ Threads onto nearly all manufacturers' spray heads and shrub adapters
- ✓ Pre-attached screen for easy installation
- ✓ Radius reduction up to 25% by turning set screw
- ✓ Color-coded to easily identify adjustable and full circle models



Female-threaded
PRN-A



Male-threaded
PRN-TA



Female-threaded
PRN-F



Male-threaded
PRN-TF



Precision™ Series Rotating Nozzles supply matched precipitation with any arc and radius from 4,3 to 7,9 meters. Water is applied slowly and evenly to reduce runoff and wasted water.

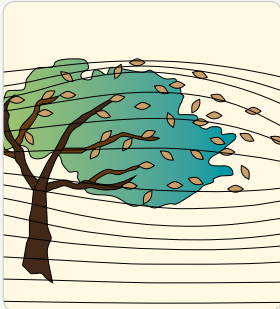

Stronger, Low Trajectory Streams for Superior Performance in Wind

Precision™ Series Rotating Nozzle's streams have trajectories under 20°, making them more resistant to wind and drift than those of competing rotating nozzles. Lower trajectory streams provide great wind resistance, especially on 12" and 6" pop-ups resulting in significantly less overspray and misting.



**360°
Full-Circle
Model**

Only Two Models Needed:

Fewer models allow for less inventory and more flexibility. Two Toro-threaded models and two female-threaded models to fit other professional brand spray heads are all that are required to cover radius requirements of 4,3 to 7,9 meters and infinitely adjustable arcs between 45° and 270° or 360°.



**45° - 270°
Adjustable
Arc Model**



Shorter Watering Times (Up to 40%) with PRN

Precision™ Spray Nozzles average 14mm per hour precipitation rate (square spacing) allowing shorter watering times. With the PSN's exceptional uniformity, close-in watering characteristics and phenomenal edge control it is the ideal nozzle for any water efficient application challenge.



Step-Up™ Technology

The unique arc adjustment ring dial allows for pre-setting the arc by hand or with the PRNTOOL before the nozzle is installed or quickly after the nozzle is threaded onto the spray head and under pressure.



Visual Arc Adjustment

The unique arc adjustment ring dial allows for pre-setting the arc by hand or with the PRNTOOL before the nozzle is installed or quickly after the nozzle is threaded onto the spray head and under pressure.

SPECIFICATIONS

Operational

- Radius: 4,3-7,9 m (14'-26')
- Operating pressure range: 1,4-5,2 Bar (20-75 psi)
- Recommended operating pressure: 2,8-3,5 Bar (40-50 psi)
- Flow Rate: 1,4-14 l/m (0.17-3.68 gpm)

Warranty

- Two years



PRECISION™ SERIES ROTATING NOZZLES PERFORMANCE DATA

Arc	Bar	LPM	Radius	Precip Rate (mm/hr)		Rotation
				■	▲	
45°	1,7	0,64	4,3	17,0	19,59	19,0
	2,1	0,87	4,6	20,0	23,09	17,0
	2,4	0,79	4,9	16,0	18,53	16,0
	3,1	1,06	5,5	16,9	19,52	15,0
	3,8	1,25	5,8	17,9	20,65	14,0
	4,5	1,48	6,7	15,8	18,20	14,0
90°	5,2	1,63	6,7	17,4	20,07	13,0
	1,7	1,63	4,9	16,4	18,97	14,0
	2,1	1,70	5,2	15,2	17,58	13,0
	2,4	2,04	5,8	14,6	16,89	13,0
	3,1	2,65	6,7	14,1	16,33	13,0
	3,8	2,99	7,0	14,6	16,87	13,0
120°	4,5	3,22	7,6	13,3	15,36	12,0
	5,2	3,48	7,6	14,4	16,62	12,0
	1,7	1,82	5,0	13,1	15,12	14,0
	2,1	2,23	5,2	15,0	17,29	12,0
	2,4	2,38	5,6	13,5	15,59	12,0
	3,1	3,48	6,7	13,9	16,10	12,0
180°	3,8	3,86	7,0	14,1	16,33	11,0
	4,5	4,20	7,3	14,1	16,32	11,0
	5,2	4,47	7,6	13,8	15,99	11,0
	1,7	3,14	4,6	18,0	20,83	12,0
	2,1	3,44	5,2	15,4	17,78	12,0
	2,4	4,01	5,8	14,4	16,58	12,0
240°	3,1	5,22	6,7	13,9	16,10	12,0
	3,8	5,83	7,0	14,2	16,44	11,0
	4,5	6,36	7,6	13,1	15,18	11,0
	5,2	6,85	7,9	13,1	15,12	10,0
	1,7	4,24	4,6	18,3	21,08	12,0
	2,1	4,58	4,9	17,3	20,02	12,0
270°	2,4	5,38	5,8	14,4	16,66	12,0
	3,1	6,47	6,4	14,2	16,42	12,0
	3,8	7,15	6,7	14,3	16,54	12,0
	4,5	7,61	7,0	13,9	16,09	11,0
	5,2	8,33	7,3	14,0	16,18	10,0
	1,7	4,09	4,3	17,9	20,69	11,0
360°	2,1	4,88	4,6	18,6	21,53	11,0
	2,4	5,19	5,5	13,7	15,88	11,0
	3,1	7,08	6,4	13,8	15,92	10,0
	3,8	8,06	6,7	14,3	16,52	10,0
	4,5	8,90	7,3	13,3	15,32	10,0
	5,2	9,84	7,6	13,5	15,62	10,0
360°	1,7	6,85	4,6	19,7	22,71	13,0
	2,1	8,18	5,5	16,3	18,82	13,0
	2,4	8,25	5,9	14,2	16,35	13,0
	3,1	11,13	6,8	14,3	16,54	13,0
	3,8	12,26	7,1	14,6	16,85	11,0
	4,5	13,17	7,4	14,4	16,64	11,0
5,2	13,93	7,8	13,7	15,85	11,0	

Nozzle data subject to change.

PRECISION™ SERIES ROTATING NOZZLE MODEL LIST

Toro (male)-threaded	Description
PRN-TA	Toro Threaded, 4,3-7,9m (14-26') Adjustable from 45°-270°
PRN-TF	Toro Threaded, 4,3-7,9m (14-26') Full-Circle
Female-threaded	
PRN-A	Threaded, 4,3-7,9m (14-26') Adjustable from 45°-270°
PRN-F	Threaded, 4,3-7,9m (14-26') Full-Circle

Specifying Information—Precision™ Series Rotating Nozzles

PRN-XX		
Model	Thread	Arc
PRN	X	X
PRN—Precision™ Rotating Nozzle	T—Toro (male)-thread Blank—Female-thread	A—Adjustable F— Full circle
Example: A male threaded Precision Series Rotating nozzle with a 7,3m (24') radius and a 180° arc would be specified as: PRN-TA A female threaded Precision Series Rotating nozzle with a 6,1m (20') radius and 360° arc would be specified as: PRN-F		

Note: For optimal performance in dirty water applications, a minimum of 120 mesh primary filtration is recommended.

Maximum irrigation efficiency with optimal product versatility: All the water-saving capabilities of Toro's Precision™ Series Spray Nozzles with the inventory-reducing advantage of true variable radius. Adjustable from 2,4m (8') to 4,6m (15') to match multiple sizes of landscape with one nozzle.



PRECISION™ SERIES H2FLO™ VARIABLE RADIUS NOZZLES

FEATURES & BENEFITS

Patented H2O Chip Technology

Variable Radius: 2,4m (8') to 4,6m (15')

Arc Options: Quarter, Half, and Full

Male or Female Thread, or pre-installed on 100mm (4") pop-up LPS Spray

PERFORMANCE DATA

VARIABLE RADIUS PRECISION™ SERIES SPRAY NOZZLES @ 2,0 BAR

QUARTER CIRCLE

Radius (m)	DU	CU	SC	LPM	Precip.Rate ■(mm/hr.)
2,4	55	73	1,4	0,9	29,7
3,0	58	75	1,3	1,2	26,9
3,7	54	73	1,3	1,5	25,1
4,6	56	75	1,2	2,2	27,2

HALF CIRCLE

Radius (m)	DU	CU	SC	LPM	Precip.Rate ■(mm/hr.)
2,4	55	73	1,4	2,0	36,1
3,0	58	75	1,3	2,4	29,2
3,7	54	73	1,3	2,9	26,2
4,6	56	75	1,2	4,4	26,4

FULL CIRCLE

Radius (m)	DU	CU	SC	LPM	Precip.Rate ■(mm/hr.)
2,4	55	73	1,4	3,5	33,5
3,0	58	75	1,3	4,5	27,7
3,7	54	73	1,3	6,7	28,7
4,6	56	75	1,2	8,1	24,6



Precision™ Series Sprinkler, 100mm(4") Pop-Up with Nozzle
53892, 53893, 53894

Variable Radius Nozzle Only (1 per Blister Pack)

Male (Toro) Threaded
Red Cap
53926, 53927, 53928

Female Threaded
Green Cap
53895, 53896, 53897

VARIABLE RADIUS PRECISION™ SERIES SPRAY NOZZLE MODEL LIST

Model	Description
100mm (4") Pop-up w/ pre-installed Variable Radius Precision™ Series Spray Nozzle – 2,4m (8') to 4,6m (15'), without PCD	
53892	100mm (4") LPS Spray w/ Variable Radius Precision™ Series Nozzle, Quarter Circle
53893	100mm (4") LPS Spray w/ Variable Radius Precision™ Series Nozzle, Half Circle
53894	100mm (4") LPS Spray w/ Variable Radius Precision™ Series Nozzle, Full Circle
Variable Radius Precision™ Series Spray Nozzle – 2,4m (8') to 4,6m (15'), Toro Thread, without PCD, (1 per Blister Pack)	
53926	Precision™ Series Spray Nozzle, Variable Radius, Toro-thread, Quarter Circle
53927	Precision™ Series Spray Nozzle, Variable Radius, Toro-thread, Half Circle
53928	Precision™ Series Spray Nozzle, Variable Radius, Toro-thread, Full Circle
Variable Radius Precision™ Series Spray Nozzle – 2,4m (8') to 4,6m (15'), Female Thread, without PCD, (1 per Blister Pack)	
53895	Precision™ Series Spray Nozzle, Variable Radius, Female-thread, Quarter Circle
53896	Precision™ Series Spray Nozzle, Variable Radius, Female-thread, Half Circle
53897	Precision™ Series Spray Nozzle, Variable Radius, Female-thread, Full Circle

MPR PLUS SPRAY NOZZLES



Additional Features

- ✓ Customized screens for each nozzle
- ✓ Fine-mesh snap-in filter screens for lower flow nozzles
- ✓ Convenient nozzle packaging – nozzles and screens packed separately
- ✓ Adjustment screw allows up to 25% reduction in radius and complete shutoff

MPR PLUS SPRAY NOZZLES MODEL LIST

Model	Description	Model	Description
1,5M (5') MPR PLUS NOZZLE-RED		2,4M (8') MPR PLUS NOZZLE-GREEN	
5Q	90° Arc	8Q	90° Arc
5T	120° Arc	8T	120° Arc
5H	180° Arc	8H	180° Arc
5TT	240° Arc	8TT	240° Arc
5TQ	270° Arc	8TQ	270° Arc
5F	360° Arc	8F	360° Arc
3,0M (10') MPR PLUS NOZZLE-BLUE		3,7M (12') MPR PLUS NOZZLE-BROWN	
10Q	90° Arc	12Q	90° Arc
10T	120° Arc	12T	120° Arc
10H	180° Arc	12H	180° Arc
10TT	240° Arc	12TT	240° Arc
10TQ	270° Arc	12TQ	270° Arc
10F	360° Arc	12F	360° Arc
4,6M (15') MPR PLUS NOZZLE-BLACK		SPECIAL PATTERNS-ORANGE	
15Q	90° Arc	4SST	Side Strip 1,2-9,1m
15T	120° Arc	4EST	End Strip 1,2-4,3m
15H	180° Arc	4CST	Center Strip 1,2-6,1m
15TT	240° Arc	9SST	Side Strip 2,7-5,2m
15TQ	270° Arc	4SSST	Side Strip 1,2-5,2m
15F	360° Arc	2SST	Side Strip 0,6-1,8m

Toro® MPR Plus nozzles make system design and installation easier than ever. Simply select the needed radius and arc—the nozzle does everything else.

FEATURES & BENEFITS

Matched Precipitation Rates

Ensures all nozzles with a common radii apply water at approximately the same rate.

Pre-installed Pressure Compensation Disc

Eliminates excessive misting, conserves water and provides precise flow rates.

SPECIFICATIONS

Operational

- Operating pressure range: 1,4-5,2 Bar
- Recommended pressure: 2,1 Bar
- Flow Rate: 0,2-17,3 LPM
- Nozzle trajectory:
1,5m (5'): 5°; 2,4m (8'): 10°; 3,0m (10'): 17°;
3,7m (12'): 24°; 4,6m (15'): 28°
Corner and Side Strips: 17°

Warranty

- Two years

Specifying Information—MPR Plus

XX-XXX-PC		
Radius	Arc	Optional
XXX	XXX	PC
5—5' 8—8' 10—10' 12—12' 15—15'	Q—90° T—120° H—180° TT—240° Q—270° F—360° EST—End Strip CST—Center Strip SST—Side Strip	PC—Pressure Compensation
Example: A 570 MPR Plus Nozzle with a spray of 3,0m(10'), 180° arc and pressure compensation, would be specified as: 10-H-PC		

Note: To specify a MPR Plus nozzle with a 570Z sprinkler body, attach the body specification before the above nozzle specification. Do not use PCDs with 570Z PR & 570Z PRX models

PERFORMANCE DATA-MPR PLUS SPRAY NOZZLES

5' SERIES WITH 5° TRAJECTORY (RED)

Arc	Desc.	Bar	LPM	Radius	Prec. Rate	
					▲	■
90°	5-Q	1.5	1.48	4.3	3.56	3.07
		2.0	1.68	4.5	4.09	3.56
		2.7	1.89	4.8	4.52	3.91
		3.5	2.29	4.9	4.72	4.11
	5-Q-PC	2.07-2.76	1.63	4.6	4.09	3.56
		2.76-5.18	1.89	4.6	4.55	3.94
120°	5-T	1.5	2.94	4.2	3.73	3.23
		2.0	3.35	4.5	4.09	3.56
		2.7	3.74	4.7	4.52	3.91
		3.5	4.43	4.7	4.72	4.11
	5-T-PC	2.07-2.76	3.26	4.6	4.09	3.56
		2.76-5.18	3.79	4.6	4.55	3.94
180°	5-H	1.5	3.92	4.1	3.56	3.07
		2.0	4.47	4.5	4.32	3.73
		2.7	4.97	4.8	4.32	3.73
		3.5	5.92	4.9	4.27	3.68
	5-H-PC	2.07-2.76	4.16	4.6	4.09	3.56
		2.76-5.18	4.54	4.6	4.55	3.94
240°	5-TT	1.5	2.63	4.3	3.99	3.45
		2.0	3.31	4.5	4.27	3.68
		2.7	3.74	4.8	4.22	3.66
		3.5	4.43	4.9	4.14	3.58
	5-TT-PC	2.07-2.76	3.33	4.6	3.91	3.40
		2.76-5.18	3.79	4.6	4.60	3.99
270°	5-TQ	1.5	0.31	4.1	4.72	4.09
		2.0	0.34	4.5	4.39	3.81
		2.7	0.36	4.7	4.27	3.68
		3.5	0.46	4.9	4.22	3.66
	5-TQ-PC	2.07-2.76	0.34	4.6	3.94	3.40
		2.76-5.18	0.38	4.6	4.39	3.81
360°	5-F	1.5	1.80	4.1	4.45	3.84
		2.0	2.05	4.5	4.32	3.73
		2.7	2.27	4.8	4.22	3.66
		3.5	2.71	4.9	4.19	3.63
	5-F-PC	2.07-2.76	1.89	4.6	3.99	3.45
		2.76-5.18	2.23	4.6	4.45	3.84

8' SERIES WITH 10° TRAJECTORY (GREEN)

Arc	Desc.	Bar	LPM	Radius	Prec. Rate	
					▲	■
90°	8-Q	1.5	1.48	4.3	3.94	3.40
		2.0	1.68	4.5	4.27	3.68
		2.7	1.89	4.8	4.09	3.53
		3.5	2.29	4.9	4.06	3.53
	8-Q-PC	2.07-2.76	1.63	4.6	3.91	3.38
		2.76-5.18	1.89	4.6	4.45	3.84
120°	8-T	1.5	2.94	4.2	4.01	3.45
		2.0	3.35	4.5	3.99	3.45
		2.7	3.74	4.7	4.24	3.68
		3.5	4.43	4.7	4.22	3.66
	8-T-PC	2.07-2.76	3.26	4.6	3.86	3.35
		2.76-5.18	3.79	4.6	4.67	4.04
180°	8-H	1.5	3.92	4.1	3.73	3.23
		2.0	4.47	4.5	4.45	3.84
		2.7	4.97	4.8	4.57	3.96
		3.5	5.92	4.9	4.57	3.96
	8-H-PC	2.07-2.76	4.16	4.6	3.91	3.38
		2.76-5.18	4.54	4.6	4.45	3.84
240°	8-TT	1.5	2.63	4.3	4.88	4.22
		2.0	3.31	4.5	4.67	4.04
		2.7	3.74	4.8	4.72	4.09
		3.5	4.43	4.9	4.62	4.01
	8-TT-PC	2.07-2.76	3.33	4.6	3.94	3.40
		2.76-5.18	3.79	4.6	4.67	4.04
270°	8-TQ	1.5	0.31	4.1	4.88	4.22
		2.0	0.34	4.5	4.50	3.89
		2.7	0.36	4.7	4.52	3.91
		3.5	0.46	4.9	4.34	3.76
	8-TQ-PC	2.07-2.76	0.34	4.6	3.78	3.28
		2.76-5.18	0.38	4.6	4.14	3.58
360°	8-F	1.5	1.80	4.1	4.29	3.71
		2.0	2.05	4.5	4.45	3.84
		2.7	2.27	4.8	4.57	3.96
		3.5	2.71	4.9	4.57	3.96
	8-F-PC	2.07-2.76	1.89	4.6	3.78	3.28
		2.76-5.18	2.23	4.6	4.45	3.84

10' SERIES WITH 17° TRAJECTORY (BLUE)

Arc	Desc.	Bar	LPM	Radius	Prec. Rate	
					▲	■
90°	10-Q	1.5	1.48	4.3	4.22	3.66
		2.0	1.68	4.5	4.55	3.94
		2.7	1.89	4.8	4.70	4.06
		3.5	2.29	4.9	4.72	4.11
	10-Q-PC	2.07-2.76	1.63	4.6	3.76	3.25
		2.76-5.18	1.89	4.6	4.22	3.63
120°	10-T	1.5	2.94	4.2	4.42	3.84
		2.0	3.35	4.5	4.45	3.84
		2.7	3.74	4.7	4.57	3.96
		3.5	4.43	4.7	4.45	3.84
	10-T-PC	2.07-2.76	3.26	4.6	3.76	3.25
		2.76-5.18	3.79	4.6	4.27	3.68
180°	10-H	1.5	3.92	4.1	4.22	3.66
		2.0	4.47	4.5	4.04	3.51
		2.7	4.97	4.8	3.99	3.45
		3.5	5.92	4.9	4.19	3.63
	10-H-PC	2.07-2.76	4.16	4.6	3.76	3.25
		2.76-5.18	4.54	4.6	4.27	3.68
240°	10-TT	1.5	2.63	4.3	3.73	3.23
		2.0	3.31	4.5	4.14	3.58
		2.7	3.74	4.8	4.24	3.68
		3.5	4.43	4.9	4.19	3.63
	10-TT-PC	2.07-2.76	3.33	4.6	3.78	3.28
		2.76-5.18	3.79	4.6	4.27	3.68
270°	10-TQ	1.5	0.31	4.1	3.84	3.33
		2.0	0.34	4.5	3.94	3.40
		2.7	0.36	4.7	4.11	3.58
		3.5	0.46	4.9	4.22	3.66
	10-TQ-PC	2.07-2.76	0.34	4.6	3.76	3.25
		2.76-5.18	0.38	4.6	4.14	3.58
360°	10-F	20	1.11	9	4.37	3.78
		30	1.49	10	4.24	3.66
		40	1.61	11	4.14	3.61
		50	1.85	11	4.34	3.76
	10-F-PC	30-40	1.33	10	3.78	3.28
		40-75	1.51	10	4.29	3.71

12' SERIES WITH 24° TRAJECTORY (BROWN)

Arc	Desc.	Bar	LPM	Radius	Prec. Rate	
					▲	■
90°	12-Q	1.5	1.48	4.3	3.76	3.25
		2.0	1.68	4.5	3.94	3.43
		2.7	1.89	4.8	4.17	3.61
		3.5	2.29	4.9	4.24	3.66
	12-Q-PC	2.07-2.76	1.63	4.6	3.78	3.28
		2.76-5.18	1.89	4.6	4.19	3.63
120°	12-T	1.5	2.94	4.2	4.01	3.48
		2.0	3.35	4.5	4.27	3.68
		2.7	3.74	4.7	4.75	4.11
		3.5	4.43	4.7	4.90	4.24
	12-T-PC	2.07-2.76	3.26	4.6	3.78	3.28
		2.76-5.18	3.79	4.6	4.14	3.58
180°	12-H	1.5	3.92	4.1	4.47	3.86
		2.0	4.47	4.5	4.29	3.73
		2.7	4.97	4.8	4.37	3.78
		3.5	5.92	4.9	4.50	3.89
	12-H-PC	2.07-2.76	4.16	4.6	3.78	3.28
		2.76-5.18	4.54	4.6	4.14	3.58
240°	12-TT	1.5	2.63	4.3	3.94	3.43
		2.0	3.31	4.5	4.29	3.71
		2.7	3.74	4.8	4.45	3.86
		3.5	4.43	4.9	4.55	3.94
	12-TT-PC	2.07-2.76	3.33	4.6	3.78	3.28
		2.76-5.18	3.79	4.6	4.14	3.58
270°	12-TQ	1.5	0.31	4.1	3.61	3.12
		2.0	0.34	4.5	4.09	3.53
		2.7	0.36	4.7	4.01	3.45
		3.5	0.46	4.9	4.04	3.51
	12-TQ-PC	2.07-2.76	0.34	4.6	3.78	3.28
		2.76-5.18	0.38	4.6	4.22	3.66
360°	12-F	1.5	1.80	4.1	3.91	3.40
		2.0	2.05	4.5	4.32	3.73
		2.7	2.27	4.8	4.27	3.71
		3.5	2.71	4.9	4.55	3.94
	12-F-PC	2.07-2.76	1.89	4.6	3.78	3.28
		2.76-5.18	2.23	4.6	4.14	3.58

15' SERIES WITH 28° TRAJECTORY (BLACK)

Arc	Desc.	Bar	LPM	Radius	Prec. Rate	
					▲	■
90°	15-Q	1.5	1.48	4.3	3.94	3.40
		2.0	1.68	4.5	4.29	3.71
		2.7	1.89	4.8	4.62	3.99
		3.5	2.29	4.9	5.46	4.72
	15-Q-PC	2.07-2.76	1.63	4.6	3.78	3.28
		2.76-5.18	1.89	4.6	4.09	3.56
120°	15-T	1.5	2.94	4.2	4.45	3.86
		2.0	3.35	4.5	4.17	3.61
		2.7	3.74	4.7	4.62	3.99
		3.5	4.43	4.7	5.16	4.45
	15-T-PC	2.07-2.76	3.26	4.6	3.78	3.28
		2.76-5.18	3.79	4.6	4.17	3.61
180°	15-H	1.5	3.92	4.1	4.55	3.94
		2.0	4.47	4.5	4.22	3.66
		2.7	4.97	4.8	4.50	3.89
		3.5	5.92	4.9	4.75	4.11
	15-H-PC	2.07-2.76	4.16	4.6	3.78	3.28
		2.76-5.18	4.54	4.6	4.17	3.61
240°	15-TT	1.5	2.63	4.3	4.04	3.51
		2.0	3.31	4.5	4.17	3.61
		2.7	3.74	4.8	4.42	3.84
		3.5	4.43	4.9	4.72	4.09
	15-TT-PC	2.07-2.76	3.33	4.6	3.78	3.28
		2.76-5.18	3.79	4.6	4.17	3.61
270°	15-TQ	1.5	0.31	4.1	4.70	4.09
		2.0	0.34	4.5	4.37	3.78
		2.7	0.36	4.7	4.72	4.09
		3.5	0.46	4.9	5.03	4.37
	15-TQ-PC	2.07-2.76	0.34	4.6	3.89	3.35
		2.76-5.18	0.38	4.6	4.22	3.66
360°	15-F	1.5	1.80	4.1	4.80	4.14
		2.0	2.05	4.5	4.55	3.94
		2.7	2.27	4.8	4.67	4.04
		3.5	2.71	4.9	5.08	4.39
	15-F-PC	2.07-2.76	1.89	4.6	3.78	3.28
		2.76-5.18	2.23	4.6	4.17	3.61

SPECIAL PATTERNS (ORANGE)

Pattern	Desc.	Bar	LPM	Special Patterns W x L (m)	Prec. Rate*
4-EST	4-EST	2.0	1.68	1.2 x 4.5	3.66
		2.7	1.89	1.4 x 5.1	2.87
		3.5	2.29	1.9 x 6.1	2.44
		2.07-2.76	1.63	1.2 x 4.4	3.51
4-EST-PC	4-EST-PC	2.76-5.18	1.89	1.2 x 4.4	4.09
		1.5	2.94	1.0 x 7.6	5.11
4-CST					

TVAN VARIABLE ARC NOZZLES

Quick, easy and infinitely adjustable! Toro® Variable Arc Nozzles (TVAN) are designed to deliver excellent irrigation efficiency with maximum versatility.

Additional Features

- ✓ Stainless steel adjustment screw allows up to 25% radius reduction
- ✓ Nozzle arc adjustment opens from a fixed left stop position indicated by an arrow on the top

FEATURES & BENEFITS

Matched Precipitation Rates

Ensures all nozzles with a common radii apply water at approximately the same rate.

Unique Grip and Turn Adjustment

Requires no tools and makes arc setting fast and simple. Adjust from the top of the nozzle – wet or dry.

Infinitely Adjustable from 0° - 360°

The TVAN provides a variety of arc settings to precisely match any terrain and reduces inventory by meeting the needs of any size or shape landscape.

Five Color-coded Nozzles

Allows for quick and easy identification even when retracted.



8' Variable Arc Nozzle



10' Variable Arc Nozzle



12' Variable Arc Nozzle



15' Variable Arc Nozzle



17' Variable Arc Nozzle



SPECIFICATIONS

Operational

- Radius: 2,4m-5,2m
- Operating pressure range: 1,4-3,5 Bar
- Recommended operating pressure: 2,1 Bar

Warranty

- Two years



Easy Grip Top
The easy grip top makes arc adjustment from 0°-360° a snap

TVAN VARIABLE ARC NOZZLES MODEL LIST

Model	Description
TVAN8	2,4m (8') Variable Arc Pattern
TVAN10	3,0m (10') Variable Arc Pattern
TVAN12	3,7m (12') Variable Arc Pattern
TVAN15	4,6m (15') Variable Arc Pattern
TVAN17	5,2m (17') Variable Arc Pattern

Performance Data TVAN Variable Arc Nozzles — Metric

Pattern	Bar	8 Series-Green				10 Series-Blue				12 Series-Brown				15 Series-Black				17 Series-Gray			
		LPM	Radius (m)	Precipitation		LPM	Radius (m)	Precipitation		LPM	Radius (m)	Precipitation		LPM	Radius (m)	Precipitation		LPM	Radius (m)	Precipitation	
90°	1,50	1,30	2,20	74,44	64,46	1,80	2,80	63,63	55,10	3,00	3,40	71,92	62,28	3,90	4,60	51,08	44,23	4,60	4,90	53,10	45,98
	2,00	1,40	2,40	67,36	58,33	1,90	3,00	58,51	50,67	3,10	3,60	66,29	57,41	4,20	4,60	55,01	47,64	5,10	5,20	52,27	45,27
	2,50	1,60	2,60	65,59	56,80	2,30	3,00	70,82	61,33	3,80	3,80	72,93	63,16	4,90	4,80	58,94	51,04	5,80	5,40	55,12	47,74
	3,00	1,80	2,70	68,43	59,26	2,60	3,00	73,90	64,00	4,50	4,10	74,19	64,25	5,60	4,90	64,64	55,98	6,50	5,50	59,55	51,57
	3,50	1,90	2,70	72,23	62,55	2,80	3,00	86,22	74,67	4,80	4,30	71,94	62,30	6,10	4,90	70,41	60,97	7,00	5,50	64,13	55,54
180°	1,50	2,10	2,20	60,12	52,07	3,20	2,50	70,95	61,44	5,20	3,40	62,33	53,98	6,50	4,10	53,58	46,40	7,40	4,40	52,97	45,87
	2,00	2,40	2,40	57,74	50,00	3,60	2,70	64,63	55,97	5,70	3,60	60,94	52,78	7,10	4,50	48,58	42,07	8,00	5,10	42,62	36,91
	2,50	2,60	2,40	62,55	54,17	3,90	2,90	64,26	55,65	6,40	4,00	55,43	48,00	8,00	4,60	52,39	45,37	10,70	5,30	52,78	45,71
	3,00	2,80	2,50	62,08	53,76	4,30	3,00	66,20	57,33	7,10	4,30	53,21	46,08	8,80	4,60	57,63	49,91	10,70	5,30	52,78	45,71
	3,50	2,90	2,80	51,26	44,39	4,70	3,00	72,36	62,67	7,70	4,30	57,71	49,97	9,40	4,60	61,56	53,31	11,60	5,50	53,14	46,02
270°	1,50	3,20	2,20	61,08	52,88	4,50	2,50	66,51	57,59	7,40	3,20	66,76	57,80	8,60	3,80	55,02	47,63	9,90	4,20	51,85	44,89
	2,00	3,50	2,40	56,13	48,60	4,90	2,70	62,09	53,76	8,10	3,90	49,20	42,59	9,90	4,50	45,16	39,10	10,80	5,10	38,36	33,21
	2,50	3,80	2,40	60,95	52,76	5,60	2,90	61,51	53,26	9,40	4,20	49,23	42,62	10,90	4,60	47,59	41,20	12,70	5,20	43,39	37,56
	3,00	4,20	2,50	62,08	53,75	6,20	3,00	63,64	55,10	10,40	4,30	51,96	44,99	11,90	4,70	49,77	43,09	14,20	5,30	46,70	40,43
	3,50	4,60	2,80	54,20	46,93	6,70	3,00	68,77	59,54	10,90	4,30	54,46	47,15	12,90	4,90	49,63	42,97	15,40	5,50	47,03	40,72
360°	1,50	4,20	2,20	60,12	52,07	6,20	2,50	68,73	59,52	8,60	3,00	66,21	57,33	9,90	3,80	47,50	41,14	11,00	5,20	28,19	24,41
	2,00	4,80	2,40	57,74	50,00	6,90	2,70	65,58	56,79	10,00	3,80	47,98	41,55	11,80	4,50	40,37	34,96	12,80	5,50	29,32	25,39
	2,50	5,50	2,60	56,37	48,82	7,90	2,90	65,09	56,36	11,10	3,60	59,34	51,39	12,90	4,60	42,24	36,58	14,20	5,50	32,52	28,17
	3,00	6,10	2,70	57,98	50,21	8,80	3,00	67,75	58,67	12,10	3,50	68,44	59,27	14,00	4,70	43,91	38,03	15,60	5,50	35,73	30,94
	3,50	6,70	2,70	63,68	55,14	9,50	3,00	73,14	63,33	12,90	3,70	65,29	56,54	15,00	4,90	43,29	37,48	17,00	5,50	38,94	33,72

▲ Precipitation rates are for triangular spacing, shown in millimeters per hour, calculated at 50% of diameter.
 ■ Precipitation rates are for square spacing, shown in millimeters per hour, calculated at 50% of diameter.
 All performance specifications are based on the stated working pressure available at the base of the sprinkler.
 Shaded data indicates optimal operating pressure.
 Data based on 360°.

Specifying Information—TVAN

TVANXX	
Model	Radius
TVAN	XX
TVAN—Toro Variable Arc Nozzle	8— 2,4m (8') Variable Arc Pattern 10— 3,0m (10') Variable Arc Pattern 12— 3,7m (12') Variable Arc Pattern 15— 4,6m (15') Variable Arc Pattern 17— 5,2m (17') Variable Arc Pattern

Example: A TVAN8 nozzle, would be specified as: **TVAN8**

PRESSURE-COMPENSATING FLOOD BUBBLERS



SPECIFICATIONS

Operational

- Recommended operating pressure range: 1,4-5,2 Bar
- Maximum pressure: 5,2 Bar
- Flow Rate: Adjustable: 0-7,6 LPM
- Fixed Flow: 0,9; 1,9; 3,8 LPM
- Adjustment screw allows up to 25% reduction in radius
- Compatible with shrub adapter, 570Z Series sprinklers, brisers and riser extenders

Warranty

- Two years

PERFORMANCE DATA FLOOD BUBBLER

Pattern	Model No.	2,5 Bar LPM	3 Bar LPM	3,5 Bar LPM	4 Bar LPM
Flood	FB-25-PC	0,95	0,95	0,95	0,95
	FB-50-PC	1,63	1,77	1,89	1,89
	FB-100-PC	3,53	3,66	3,79	3,79
	FB-200-ADJ-PC	7,05	7,32	7,57	7,57

PRESSURE-COMPENSATING FLOOD BUBBLERS MODEL LIST

Model	Description
FB-25-PC	0,9 LPM (0.25 GPM)
FB-50-PC	1,9 LPM (0.50 GPM)
FB-100-PC	3,8 LPM (1.00 GPM)
FB-200-ADJ-PC2.00	Adjustable GPM (LPM)

500 SERIES BUBBLERS



SPECIFICATIONS

Operational

- Operating pressure range:
 - Flood: 1,0-5,2 Bar
 - Stream: 0,7-5,2 Bar
- Maximum pressure: 5,2 Bar
- Flow Rate:
 - Flood: 6,4-10,2 LPM
 - Stream: 4,1-14,0 LPM
- Inlet: ½" female thread
- Attaches directly to risers
- Radius adjusts up to 50%

Warranty

- Two years



ADJUSTABLE FLOOD BUBBLER NOZZLE PERFORMANCE DATA

Pattern	Model No.	Bar	LPM
Universal Flood	514-20	1,00	6,32
		1,25	7,14
		1,50	7,84
		1,75	8,38
		2,00	8,93
		2,25	9,28
		2,50	9,65
		2,75	10,20

PERFORMANCE DATA ADJUSTABLE STREAM BUBBLER

Model Number	Stream Patterns	1 Bar		1,5 Bar		2 Bar		2,5 Bar		3 Bar	
		Flow (LPM)	Radius (m)	Flow (LPM)	Radius (m)	Flow (LPM)	Radius (m)	Flow (LPM)	Radius (m)	Flow (LPM)	Radius (m)
511-30	2/60°	4,84	3,6	5,99	4,4	6,95	4,8	7,62	5,1	8,25	5,3
512-30	4/60°	6,72	2,5	8,30	3,1	9,59	3,3	10,71	3,7	11,81	4,2
514-30	6/60°	8,38	2,1	10,27	2,5	11,89	3,0	13,3	3,2	14,67	3,5
516-30	2/180°	4,84	3,6	5,99	4,4	6,95	4,8	7,62	5,1	8,25	5,3

Data based on 360°.

500 SERIES BUBBLERS MODEL LIST

Model	Description
511-30	90° Arc, Stream Bubbler
512-30	180° Arc, Stream Bubbler
514-30	360° Arc, Stream Bubbler
516-30	180° Arc, 2-stream Bubbler
514-20	Universal Flood Bubbler

STREAM SPRAY NOZZLES



SPECIFICATIONS

Operational

- Operating pressure range: 1,4-5,2 Bar (20-75 psi)
- Flow Rate: 2,3-10,2 LPM (0,60 – 2,70 GPM)
- Radius adjusts up to 50%
- 10° or 35° Angle
- Non-Rotating

Warranty

- Two years



PERFORMANCE DATA 10° STREAM SPRAY

Pat-tern	Desc.	Bar	LPM	Radius	Prec. Rate*	
					▲	■
90°	10-SSQ	1,5	2,40	4,4	3,45	3,00
		2,0	2,95	4,8	3,53	3,05
		2,5	3,31	5,1	3,61	3,12
	3,5	3,93	5,5	3,58	3,10	
10-SSQ-PC	2,8-3,5	2,65	4,0	4,67	4,06	
	4,1-4,8	2,65	4,6	3,51	3,05	
180°	10-SSH	1,5	3,92	4,4	2,87	2,49
		2,0	4,47	4,8	2,64	2,29
		2,5	4,97	5,1	2,69	2,34
	3,5	5,92	5,5	2,69	2,34	
	10-SSH-PC	2,8-3,5	5,30	4,0	4,67	4,06
4,1-4,8		5,30	4,6	3,51	3,05	
360°	10-SSF	1,5	7,01	4,4	2,59	2,24
		2,0	7,84	4,8	2,31	2,01
		2,5	8,71	5,1	2,36	2,06
	3,5	10,30	5,5	2,36	2,03	
	10-SSF-PC	2,8-3,5	6,81	4,0	3,00	2,62
4,1-4,8		7,57	4,6	2,51	2,18	

PERFORMANCE DATA 35° STREAM SPRAY

Pattern	Desc.	Bar	LPM	Radius	Prec. Rate*	
					▲	■
90°	35-SSQ	1,5	2,40	5,6	2,08	1,80
		2,0	2,95	6,0	2,26	1,96
		2,5	3,31	6,3	2,36	2,03
	3,5	3,93	6,7	2,41	2,08	
35-SSQ-PC	2,8-3,5	2,65	5,2	2,74	2,36	
	4,1-4,8	2,65	5,5	2,44	2,11	
180°	35-SSH	1,5	3,92	5,6	1,75	1,50
		2,0	4,47	6,0	1,70	1,47
		2,5	4,97	6,3	1,78	1,52
	3,5	5,92	6,7	1,80	1,57	
	35-SSH-PC	2,8-3,5	5,30	5,2	2,74	2,36
4,1-4,8		5,30	5,5	2,44	2,11	
360°	35-SSF	1,5	7,01	5,6	1,57	1,37
		2,0	7,84	6,0	1,47	1,30
		2,5	8,71	6,3	1,55	1,35
	3,5	10,30	6,7	1,57	1,37	
	35-SSF-PC	2,8-3,5	6,81	5,2	1,75	1,52
4,1-4,8		7,57	5,5	1,75	1,50	

STREAM SPRAY NOZZLES MODEL LIST

Model	Description	Model	Description
NON-PRESSURE COMPENSATING		PRESSURE COMPENSATING	
10-SSQ	90° Arc	10-SSQ-PC	90° Arc
10-SSH	180° Arc	10-SSH-PC	180° Arc
10-SSF	360° Arc	10-SSF-PC	360° Arc
35-SSQ	90° Arc	35-SSQ-PC	90° Arc
35-SSH	180° Arc	35-SSH-PC	180° Arc
35-SSF	360° Arc	35-SSF-PC	360° Arc

STREAM BUBBLER NOZZLES



SPECIFICATIONS

Operational

- Operating pressure range: 0,7-5,2 Bar
- Flow Rate: 1,9-9,0 LPM
- Fits all Toro spray bodies, Shrub adapters, risers and Riser extenders

Warranty

- Two years



PERFORMANCE DATA STREAM BUBBLER

Description	Stream Patterns	1 Bar		1,5 Bar		2 Bar		2,5 Bar		3 Bar		3,5 Bar		4 Bar	
		Flow (LPM)	Rad (m)	Flow (LPM)	Rad (m)	Flow (LPM)	Rad (m)	Flow (LPM)	Rad (m)	Flow (LPM)	Rad (m)	Flow (LPM)	Rad (m)	Flow (LPM)	Rad (m)
SB-90	☺ 2/60°	2,2	2,7	2,8	3,5	3,2	3,9	3,6	4,3	3,9	4,7	4,3	4,9	4,6	5,4
SB-90-PC2	☺ 2/60°							0,8	0,5	0,9	0,5	0,9	0,5	0,9	0,5
SB-180	☺ 4/60°	3,8	2,1	4,6	2,9	5,3	3,6	6,0	4,0	6,6	4,5	7,1	4,9	7,5	5,1
SB-180-PC2	☺ 4/60°							1,8	0,8	1,9	0,8	1,9	0,8	1,9	0,8
SB-360	☺ 6/60°	5,2	1,3	6,4	1,9	7,4	2,4	8,3	2,6	9,0	2,8	9,7	3,1	11,8	3,7
SB-360-PC2	☺ 6/60°							2,8	0,5	2,9	0,5	2,9	0,5	2,9	0,5
SB-2-180	☺ 2/180°	2,2	2,7	2,8	3,5	3,2	3,9	3,6	4,3	3,9	4,7	4,3	4,9	4,6	5,4
SB-2-180-PC2	☺ 2/180°							0,8	0,5	0,9	0,5	0,9	0,5	0,9	0,5
SB-4-180	☺ 2/60°x2/60°	3,8	2,1	4,6	2,9	5,3	3,6	6,0	4,0	6,6	4,5	7,1	4,9	7,5	5,1
SB-4-180-PC2	☺ 2/60°x2/60°							1,8	0,8	1,9	0,8	1,9	0,8	1,9	0,8

Data based on 360°.

STREAM BUBBLER NOZZLES MODEL LIST

Model	Description
PRESSURE COMPENSATING	
SB-90-PC2	90° Arc, 0,6m (2') Radius
SB-180-PC2	180° Arc, 0,6m (2') Radius
SB-360-PC2	360° Arc, 0,6m (2') Radius
SB-2-180-PC2	180° Arc, 2 Stream, 0,6m (2') Radius
SB-4-180-PC2	180° Arc, 4 Stream, 0,6m (2') Radius

PRECISION™ CHECK VALVE

Low head drainage can be seen in an elevation change of fewer than six inches. The resulting runoff and water waste can lead to landscape erosion, unsafe conditions on hardscapes and sidewalks, and pooling around spray heads. The Toro Precision™ Check Valve saves water and eliminates runoff by immediately sealing the spray head at its connection point at the end of the irrigation cycle, thereby preventing the draining of lateral lines through the lowest-lying heads.



FEATURES & BENEFITS

Hold Back Strength of Up to 15 Feet

Capable of compensating for elevation changes in a zone of up to 15 feet, the Precision™ Check Valve (PCV) eliminates issues with low head drainage and the resulting water waste.

Spring-Actuated Design

Spring actuation ensures an immediate check when the irrigation cycle ends.

Low Profile

With an overall profile of just under 1 1/4" cubic inches, the PCV-500 adds less than 3/8" of height to retrofitted spray heads and can be retrofit to side inlet spray heads with minimal digging. The low profile design makes the PCV-500 ideal for turf or slope applications.

A Universal Fit

Featuring 1/2" NPT threads, the PCV fits all major manufacturers' spray bodies and fittings.



PRECISION™ CHECK VALVE MODEL LIST

Model	Description
PCV-500	15' Check Valve, 1/2" NPT

PCV-500 PRESSURE LOSS DATA

Flow Rate (gpm)	1	2	3	4	5
Pressure Loss (psi)	5.1	6.0	6.5	7.0	10.2

Note: Use of the PCV-500 is not recommended for irrigation systems with dynamic operating pressure of less than 35 psi.

Specifying Information—Precision™ Check Valve

PCV-XXX	
Model	Thread Size
PCV	XXX
PCV—Precision™ Check Valve	500—1/2" NPT, MxF

SPRAY TOOLS & ACCESSORIES

EFFLUENT WATER INDICATORS

570S

(Nozzle not included)

- 570 Series shrub adapter
- Installs onto a 1/2" NPT riser



570S-E

(Nozzle not included)

- Lavender molded 570S Series shrub adapter
- Installs onto a 1/2" NPT riser



SERVICEABLE PARTS

570SEAL

- Serviceable seal for all 570Z models
- Recommended for upgrades



Check Valve 570CV

- Check valve for all the 570Z models
- Install in field to prevent low head drainage
- 10' hold back



TOOLS

89-6395

- Riser pull-up and screen removal tool for all 570Z Series models



PRNTOOL

- Adjustment Tool for Precision™ Series Rotating Nozzles
- Adjusts arc and radius



RISERS AND EXTENDERS

89-9752

- Lavender snap-on cover for use on 570Z Series pop-up models



102-1211

- Lavender molded cap for use on 570Z Series pop-up models
- Includes wiper seal



570-6X

- 570Z Extender
- Male-inlet threads install onto any 570Z pop-up sprinkler or shrub adapter to provide 15cm (6") extension
- Maximum pressure: 5,2 Bar (75 psi)



570SR-6 and 570SR-18

- 570Z stationary riser
- 1/2" male-threaded inlet for installation on pipe fittings
- Maximum pressure: 5,2 Bar (75 psi)
- Height: 15cm (6"), 45cm (18")



PNOZZTOOL

- Riser pull up tool
- Fits all 570Z Sprays



ACCESSORIES

995-01

- Flow gauge



PCV-500

- Precision Check Valve 1/2" FxM Thread.
- Minimum operating pressure: 2,75 bar
- Check height: up to 4,5 m



PIPING

This unique piping acts like an extension cord, allowing you to put sprinklers exactly where you want them. Even deep-seated high-pops are easy to install in difficult, hard-to-trench locations.



TORO

SUPER FUNNY PIPE®

Toro® Super Funny Pipe is practical and saves time. Whether you are installing a new system or replacing an old sprinkler, Super Funny Pipe makes the job easier.

SPECIFICATIONS

Operational

- Maximum pressure: 8,3 Bar
- Cushions sprinklers from external impact
- Connects to sprinklers and Toro fittings

Dimensions

- Wall thickness: 2,5mm ± 0,25
- Inside diameter: 12,4mm ± 0,13
- Outside diameter: 17,8mm

Warranty

- Two years

FEATURES & BENEFITS

Flexible, Thick-walled Polyethylene Pipe

Super Funny Pipe is a high-strength poly tubing that solves tough sprinkler installation and replacement problems. It acts as an extension cord between the water line and the sprinkler.

Easy Installation For Problem Areas

One of the most useful and time-saving sprinkler installation aids whether you are installing a new system or replacing an old sprinkler. Also comes pre-assembled as the Super Funny Pipe Swing Joints in 20,3 cm (8") and 30,5 cm (12") lengths or just get the individual fittings as needed.



SUPER FUNNY PIPE FRINCTION LOSS DATA - LPM FLOW

LPM	5	10	15	20	25
BAR Loss	0,30	1,02	2,00	3,77	5,58

This chart indicates the amount of pressure loss Bar per meter of Super Funny Pipe at stated flow rates (LPM).

SUPER FUNNY PIPE MODEL LIST

Model	Description
850-23	6,1m (20') Length, 9,5mm (3/8") Polyethylene Pipe
850-24	15,2m (50') Coil, 9,5mm (3/8") Polyethylene Pipe
850-25	30,5m (100') Coil, 9,5mm (3/8") Polyethylene Pipe

SUPER FUNNY PIPE® SWING JOINTS

SPFA-5125



SPFA-585



SPFA-51275



SPFA-5875



SPECIFICATIONS

Warranty

- Two years

SUPER FUNNY PIPE SWING JOINTS MODEL LIST

Model	Description
SPFA-585	200 x 13mm (8" x 1/2")
SPFA-5875	200 x 20mm (8" x 3/4")
SPFA-5125	300 x 13mm (12" x 1/2")
SPFA-51275	300 x 20mm (12" x 3/4")

SUPER FUNNY PIPE® FITTINGS

850-20



850-34



850-31



850-35



850-32



850-36



850-33



850-37



SUPER FUNNY PIPE FITTINGS FRICTION LOSS DATA

Model No.	Description	LPM Flow				
		5	10	15	20	25
850-36	20mm Male Adapter	1,35	4,13	9,55	21,7	37,7
850-35	13mm Male Adapter	0,89	3,08	6,89	16,1	28,2
850-31	13mm Male Elbow	1,87	6,43	13,8	28,7	46,9
850-34	13mm Female Elbow	1,87	6,43	13,8	28,7	46,9
850-32	20mm Male Elbow	2,23	7,42	17,8	7,10	61,4

This chart indicates the amount of pressure loss Bar per meter of Super Funny Pipe at stated flow rates (LPM).

SUPER FUNNY PIPE FITTINGS MODEL LIST

Model	Description
850-20	Coupling
850-31	Male Elbow, 1/2"
850-32	Male Elbow, 3/4"
850-33	Female Adapter, 1/2" - 3/4"
850-34	Female Elbow, 1/2"
850-35	Male Adapter, 1/2"
850-36	Male Coupling, 3/4"
850-37	Tee, Barbed Inserts
850-60	Saddle Tee, 3/4"
850-61	Saddle Tee, 1"

SPECIFICATIONS

Warranty

- Two years

ROTORS

Dependable, reliable performance is what you will find with Toro rotors for residential, commercial and sports field applications. In addition, you will also find innovative features such as NO TOOLS arc adjustment, higher pop-up heights and some of the most efficient nozzles in the industry.



TORO



ROTORS

Pages 43-72

Mini 8 Series	45-48
300 Series Stream Rotor®	49-52
T5 RapidSet® Series	53-56
T7 Series Rotors	57-60
640 Series Rotors	61-64
TS90® Series Rotors	65-68
690 Series Rotors	69-71
Rotor Accessories	72

Simple to use, water-efficient, and versatile, the Mini 8 Series does it all. Designed to meet coverage areas between 6,1 m and 10,7 m radius, the Mini 8 has a simple to use top-of-rotor arc setting feature that ensures easy and accurate arc adjustments from 40 degrees to reversing full-circle 360 degrees. Furthermore, the pressure-activated riser seal, robust trip mechanism, ratcheting riser, and pre-installed 1.5 gpm nozzle combine for easy installations and reliable long-term performance. When spray heads won't do the job and a full-size rotor is more than what is needed, the Mini 8 rotor from Toro is the ideal choice.



TORO

MINI 8 SERIES ROTORS

FEATURES & BENEFITS

Top-of-Rotor Arc Adjustment

Allows easy arc setting with a slotted screwdriver and features a quick reference dial for fast and accurate adjustments (40° to 360°).

Pressure-activated Riser Seal

Helps prevent debris intrusion into the rotor's body and, ultimately, the system's water lines.

Ratcheting Riser

Allows the riser and fixed left edge to quickly be turned to the desired position without having to re-orient the entire rotor.

Five Interchangeable Nozzles

To cover varying flow and radius requirements.

Part and Full Circle In One

Offers more flexibility on new system installs and reduces inventory requirements.



Nozzle Tree
Five interchangeable nozzles – comes pre-installed with a 1.5 nozzle



Check Valve
Optional for field installations



Check Valve
Options Available

PRODUCT HIGHLIGHT

Arc Setting

Visual arc setting dial within rubber cover allows for fast and easy arc adjustments.

Infinite arc adjustment from 45° to 360°

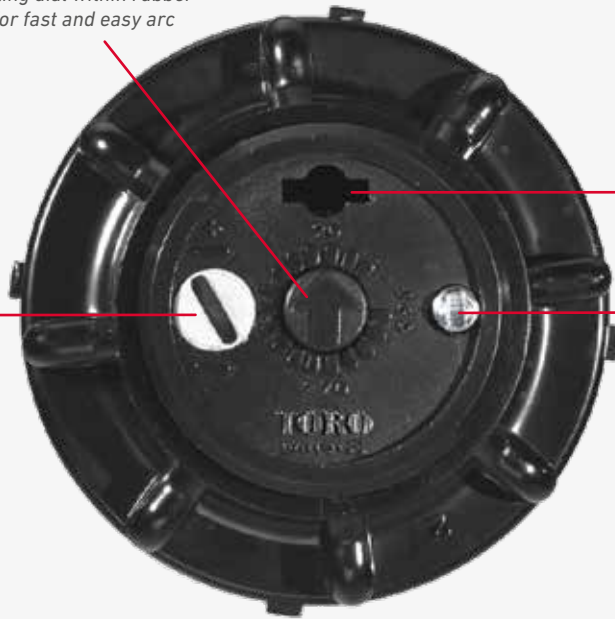

Dry pull-up shot

Dry pull-up shot

Not Too Big and Not Too Small – the Mini 8 is Just Right

The Mini 8 nozzles are designed for the efficient watering of smaller spaces, which means water savings when compared to full-size rotors. When compared to fixed sprays, the flexibility of the Mini 8 reduces the number of heads required, which in turn reduces the number of valves and stations needed. In either scenario, the Mini 8 brings together money savings and better water management.



SPECIFICATIONS

Operational

- Radius: 6,1-10,7m
- Arc Adjustment – 40° to 360°
- Operating Pressure Range: 2,0-3,4 Bar
- Flow Rate: 3,0-12,9 LPM
- Trajectory: 25°

Dimensions

- Body height: 150mm (6")
- Pop-up to nozzle height: 95mm
- Exposed diameter: 45mm
- Cap diameter: 57mm
- Inlet: ½" female-threaded

Options Available

- MINI8-CV – Check Valve – maintains up to 8' elevation change (Bag of 25)
- 102-2024 – Adjustment Tool

Warranty

- Two years

MINI 8 SERIES MODEL LIST

Model	Description
MINI8-4P	Mini 8 Rotor, 100mm (4") Lawn Pop-up

MINI 8 SERIES PERFORMANCE DATA

Nozzle	Bar	LPM	Radius	Prec. Rate	
				▲	■
0.75	2,0	3,0	6,1	5,6	4,8
	2,5	3,3	6,3	5,8	5,0
	3,0	3,8	6,5	6,2	5,4
	3,5	4,6	6,7	7,1	6,1
1.0	2,0	4,2	7,9	4,7	4,0
	2,5	4,6	8,1	4,8	4,2
	3,0	5,2	8,3	5,2	4,5
	3,5	5,7	8,6	5,3	4,6
1.5	2,0	4,5	8,8	4,0	3,5
	2,5	5,0	9,0	4,3	3,7
	3,0	5,6	9,3	4,5	3,9
	3,5	6,1	9,5	4,7	4,0
2.0	2,0	5,3	9,1	4,4	3,8
	2,5	6,0	9,3	4,8	4,2
	3,0	6,8	9,4	5,3	4,6
	3,5	7,7	9,4	6,0	5,2
3.0	2,0	8,7	10,3	5,7	4,9
	2,5	9,4	10,6	5,8	5,0
	3,0	10,4	10,7	6,3	5,4
	3,5	11,5	10,7	6,9	6,0

Radius shown in meters. Data based on 360°.

▲ Precipitation rates are for triangular spacing, shown in millimeters per hour, calculated at 50% of diameter.

■ Precipitation rates are for square spacing, shown in millimeters per hour, calculated at 50% of diameter.

All performance specifications are based on the stated working pressure available at the base of the sprinkler.

* Pre-installed nozzle.

Specifying Information—Mini 8 Series Rotors

MINI8-4P-XX-E			
Description	Body	Nozzle	Optional
MINI8	4P	XX	XX
MINI8—Mini 8 Rotor	4P—Lawn Pop-up	75-0.75 gpm 10-1.0 gpm 15-1.5 gpm 20-2.0 gpm 30-3.0 gpm	CV-Check Valve

Example: A Mini 8 Series sprinkler with a 3.0 nozzle, would be specified as: **MINI8-4P-30**

The 300 Series Multi-Stream Rotor® from Toro combines a highly distinctive way to irrigate with the reliability you've come to expect. Uniquely designed, Stream Rotors feature multiple rotating streams, a slower precipitation rate and successfully fights wind. The 300 Series utilizes Matched Precipitation Rate (MPR) nozzles ensuring precise, proportional flow for uniform water coverage every time. Interchangeable arc plates and nozzles provide the ultimate in versatility with the ability to cover varying arc requirements from 90 to 360 degrees. Durable plastic and stainless steel construction along with a wide selection of body styles—pop, shrub and high-pop—make the 300 Series ideal for medium to large lawns and ground cover. You can literally see the difference!



300 SERIES MULTI-STREAM ROTOR®

FEATURES & BENEFITS

Unique Multiple Rotating Streams

Provides slow, effective watering, and the ability to couple different arcs on the same zone, which saves time and water.

Matched Precipitation Rate Arc Discs

Ensures uniform delivery of water across each square foot of an irrigated area, resulting in high-precision water application.

Choice Of Six Nozzles and Nine Interchangeable Arc Discs

For maximum versatility covering varying landscape needs.



300 Series arc discs come in nine different selections



Effluent Options Available



Check Valve Options Available

PRODUCT HIGHLIGHT



A Winning Combination of Watering Efficiency and Visual Appeal

The exclusive "fingers of water" application takes a flow of water and divides it into smaller streams at different trajectories for a stronger performance all across the landscape. Shorter radii get the coverage needed with enough water still in the main stream to reach longer distances. This also creates a heavier watering stream at the tail end of the spray allowing for greater wind resistance.



SPECIFICATIONS

Operational

- Radius: 4,6-9,2m
- Flow Rate:
 - Lawn Pop-up and High-pop: 2,1-28,4 LPM
 - Shrub (COM): 7,8-24,0 LPM
- Operating Pressure Range: 2,4-3,5 Bar
- Pop-up Height to Nozzle:
 - Lawn Pop-up: 70mm
 - High-Pop: 298mm
- Inlet (Female-threaded):
 - Lawn Pop-up and High-pop: ¾"
 - Shrub: ½" to ¾"
- Large basket filter screen

Dimensions

- Body Diameter: 60mm
- Cap Diameter: 75mm
- Height:
 - Lawn Pop-up: 155mm
 - High-Pop: 405mm
- Shrub Base Diameter: 45mm

Options Available

- Recycled Water Indicators:
- Lavender Cover, High-Pop (89-7854 - fits 300-25 Omni only)
 - Lavender Cover, Lawn & Shrub (89-7853 - fits 300-15 Omni only)
 - Lavender Cap, Standard Nozzles (89-7889 - fits 01, 02, 03, 63, 93)
 - COM Check Seal (89-7561) (Fits Shrub model only)
 - 35-1344 — Locking cap for Lawn Pop-up models (standard on high-pop models)

Warranty

- Two years

300 SERIES: 300-15 (LAWN) AND 300-25 (HIGH POP) OMNI PERFORMANCE CHART

Bar	Radius (m)	Precipitation Rate*		360°	270°	225°	202.5°	180°	157.5°	135°	112°	90°
		▲	■	Flow (at Designated Arcs) (LPM)								
2,5	4,5	44,1	38,2	12,9	9,7	8,1	7,3	6,5	5,7	4,9	4,0	3,2
	5,0	39,0	33,8	14,1	10,6	8,8	8,0	7,1	6,2	5,3	4,4	3,5
	6,0	31,9	27,6	16,6	12,5	10,4	9,3	8,3	7,3	6,2	5,2	4,2
	7,0	27,0	23,3	19,1	14,3	11,9	10,7	9,6	8,4	7,2	5,9	4,8
	8,0	24,0	20,8	22,2	16,7	13,9	12,5	11,1	9,7	8,3	6,9	5,6
3,5	6,0	36,9	31,9	19,2	14,4	12,0	10,8	9,6	8,4	7,2	6,0	4,8
	7,0	31,3	27,1	22,2	16,7	13,9	12,5	11,1	9,7	8,3	6,9	5,6
	8,0	27,2	23,6	25,2	18,9	15,7	14,2	12,6	11,0	9,4	7,8	6,3
	9,0	24,1	20,9	28,2	21,1	17,6	15,8	14,1	12,3	10,6	8,8	7,0
	10,0	21,6	18,7	31,2	23,4	19,5	17,5	15,6	13,6	11,7	9,7	7,8

300 SERIES: FIXED RADIUS NOZZLE PERFORMANCE CHART

Nozzle	Bar	Radius (m)	Precipitation Rate*		360°	270°	225°	202.5°	180°	157.7°	135°	112°	90°
			▲	■	Flow (at Designated Arcs) (LPM)								
01	2,5	4,9	25,4	22,0	8,8	6,6	5,5	4,9	4,4	3,9	3,3	2,8	2,2
	3,5	5,5	25,2	21,8	11,0	8,3	6,9	6,2	5,5	4,8	4,1	3,4	2,8
02	2,5	6,5	18,2	15,7	11,1	8,3	6,9	6,2	5,5	4,8	4,2	3,5	2,8
	3,5	7,4	16,4	14,2	13,0	9,8	8,1	7,3	6,5	5,7	4,9	4,1	3,3
03	2,5	8,6	19,5	16,9	20,9	15,7	13,1	11,7	10,4	9,1	7,8	6,5	5,2
	3,5	9,2	20,1	17,4	24,6	18,5	15,4	13,8	12,3	10,8	9,2	7,7	6,2
63*	2,5	8,6	9,8	8,5	10,5	7,8	6,5	5,9	5,2	4,6	3,9	3,3	2,6
	3,5	9,2	10,1	8,7	12,3	9,2	7,7	6,9	6,2	5,4	4,6	3,9	3,9
93*	2,5	8,6	14,7	12,7	15,7	11,7	9,8	8,8	7,8	6,9	5,7	4,9	3,9
	3,5	9,2	15,1	13,1	18,5	13,9	11,5	10,4	9,2	8,1	6,9	5,8	4,6

*Radius shown in meters. Data based on 360°.

▲ Precipitation rates are for triangular spacing, shown in millimeters per hour, calculated at 50% of diameter.

■ Precipitation rates are for square spacing, shown in millimeters per hour, calculated at 50% of diameter.

All performance specifications are based on the stated working pressure available at the base of the sprinkler.

300 SERIES SHRUB WITH COM (360° ARC DISC)

Model Nos. 300-10-00COM —Metric

Nozzle	Bar	LPM	Radius
01	3,5	7,9	4,3
01	5,0	10,8	4,8
02	3,5	9,5	7,0
02	5,0	13,5	7,6
03	3,5	17,4	8,2
03	5,0	23,0	8,8
63	3,5	10,2	8,6
63	5,0	14,0	9,1
93	3,5	14,0	8,9
93	5,0	19,4	9,4
Omni (Min)	3,5	10,2	4,9
Omni (Min)	5,0	14,5	5,4
Omni (Max)	3,5	21,1	9,2
Omni (Max)	5,0	23,8	10

300 SERIES LAWN POP-UP APEX @ 3,5 BAR

Nozzle	27°
	Max. Ht. of Spray
01	1,47 m
02	1,55 m
03	1,8 m
63	2,1 m
93	1,9 m

300 SERIES MULTI-STREAM ROTOR MODEL LIST

Model	Description
300-00-00	Lawn Pop-up without Nozzle
300-10-00	Shrub without Nozzle
300-12-00	12" High Pop without Nozzle

Specifying Information—300 Series Multi-Stream Rotor

3XX-XX-XX-COM-E				
Arc	Body	Nozzle	Optional COM	Optional E
3XX	XX	XX	COM	E
04—90° 05—112° 06—135° 07—157.5° 08—180° 09—202.5° 10—225° 12—270° 16—360°	00—Lawn Pop-up 10—Shrub 12—High Pop	01/21—Small Radius, 12 Ports 02/22—Medium Radius, 12 Ports 03/23—Large Radius, 12 Ports 15—Adjustable Shrub & Lawn Pop-up 25—Adjustable, High Pop-up 63—Large Radius, 6 Ports, Low flow* 93—Large Radius, 9 Ports, Low flow*	COM—Check-O-Matic (COM available on shrub model only)	E—Effluent

Example: A 300 Series Shrub Sprinkler with a 90° arc and an adjustable nozzle, would be specified as: **304-10-15**

* Available on Lawn Pop-up and Shrub only.

The Toro® T5 RapidSet rotor can be set in seconds. Engineered to use the slip clutch to adjust the arc, the T5 RapidSet rotor requires NO TOOLS for arc adjustments. Along with a five inch pop-up height of the Lawn model, the T5 RapidSet rotors feature exclusive Airfoil Technology™ standard and low angle nozzles that deliver class-leading* distribution uniformity. Designed to save water, save time, and save money, the T5 RapidSet rotor is the only 3/4" rotor needed to get the job done.



**Based on independently tested performance profiles from the Center for Irrigation Technology*

T5 RAPIDSET® SERIES ROTORS

FEATURES & BENEFITS

RapidSet® Arc Adjustment

Arc adjustments from 40° to 360° can be made quickly with a few twists of the turret – no tools required. The RapidSet slip clutch also protects against gear damage caused by intentional vandalism or inexperienced users.

Lawn Model with a 12,7cm Pop-up Height

Fits in the same footprint as many competing 100mm (4") rotors for hassle-free retrofits, but delivers an extra inch of pop-up height, allowing the nozzle to clear tall grasses.

Airfoil Technology™ Nozzles

The T5 RapidSet rotor comes with a full set of 8 standard nozzles (25° trajectory) and 4 low angle (10° trajectory) nozzles that utilize proprietary Airfoil Technology, which creates a zone of low pressure just below the main stream to gently guide water downward for unmatched uniformity without forcefully washing out newly-laid seeds.

Design Flexibility

T5 RapidSet rotors are available in Effluent, Shrub, 305mm (12") High Pop and Stainless Steel models.

Stainless Steel Model Features

- ✓ 304 Stainless Steel riser and nozzle base protection
- ✓ Ideal for settings with heavy foot traffic or sandy soil conditions
- ✓ Heavy-duty construction protects the rotor from damage caused by vandalism

T5 RAPIDSET® ROTOR MODEL LIST

Model	Description
T5P-RS	127mm RapidSet Lawn pop-up
T5PE-RS	127mm RapidSet Lawn pop-up, Effluent
T5PCK-RS	127mm RapidSet Lawn pop-up with Check Valve
T5HP-RS	305mm (12") RapidSet High Pop
T5HPE-RS	305mm (12") RapidSet High Pop, Effluent
T5S-RS	RapidSet Shrub
T5SE-RS	RapidSet Shrub, Effluent
T5PSS-RS	127mm RapidSet Stainless Steel Lawn pop-up
T5PSSE-RS	127mm RapidSet Stainless Steel Lawn pop-up, Effluent
T5PCKSS-RS	127mm RapidSet Stainless Steel Lawn pop-up with Check Valve
T5CKSSE-RS	127mm RapidSet Stainless Steel Lawn pop-up with Check Valve and Effluent Cover



Effluent Options Available



Check Valve Options Available

PRODUCT HIGHLIGHT

NO TOOLS Arc Adjustment



12.7cm Pop-Up In a 4"(100mm) Body



Exclusive Airfoil™ Technology Nozzles



T5 RapidSet Stainless Steel Rotors

CLASS-LEADING DISTRIBUTION UNIFORMITY

3.0 Nozzle, 3.0 Bar, Square Spacing

Competitor	Uniformity (%)
Competitor 1	65%
Competitor 2	75%
Toro T5	82%

Based on independently tested performance profiles from the Center for Irrigation Technology

SPECIFICATIONS

Operational

- Radius: 7,6-15,2m
- Flow rate: 2,8-36,5 LPM
- Arc: 40° to 360°, adjustable
- Inlet: ¾" NPT
- Operating pressure range: 1,7-4,5 bar
- Recommended operating pressure: 3,0 Bar
- Trajectory: 25° standard, 10° low angle
- Pop-up height: 12,7 cm (measured from top of cap to nozzle high-pop height opening)
- Factory installed with a #3.0 nozzle (pre-installed)

Dimensions

- Body Diameter:
 - Lawn Pop-up: 57mm
 - Shrub: 57mm
 - High Pop: 57mm
- Cap Diameter:
 - Lawn Pop-up: 67mm
 - Shrub: N/A
 - High Pop: 67mm
- Height:
 - Lawn Pop-up: 190mm
 - Shrub: 196mm
 - High Pop: 429mm

Warranty

- Five years

T-5 LOW ANGLE NOZZLE PERFORMANCE DATA

Nozzle	Pressure Bar	Radius m	Flow m³/hr	Flow l/m	Precipitation Rate (mm/hr)	
					■	▲
1.0 LA	1,7	7,62	0,17	2,8	5,79	6,68
	2,0	7,99	0,19	3,1	5,84	6,74
	2,5	8,53	0,22	3,6	5,93	6,84
	3,0	8,53	0,23	3,8	6,29	7,26
	3,5	8,71	0,25	4,1	6,52	7,53
	4,0	8,84	0,27	4,4	6,82	7,88
	4,5	8,84	0,28	4,7	7,27	8,39
1.5 LA	1,7	8,23	0,25	4,2	7,38	8,52
	2,0	8,60	0,27	4,5	7,38	8,52
	2,5	9,18	0,31	5,2	7,39	8,53
	3,0	9,40	0,34	5,7	7,68	8,87
	3,5	9,45	0,38	6,3	8,41	9,71
	4,0	9,45	0,41	6,8	9,13	10,55
	4,5	9,45	0,43	7,2	9,67	11,16
2.0 LA	1,7	8,84	0,32	5,3	8,14	9,40
	2,0	9,08	0,35	5,8	8,41	9,72
	2,5	9,49	0,40	6,7	8,89	10,27
	3,0	9,71	0,45	7,6	9,64	11,14
	3,5	9,93	0,49	8,2	9,98	11,52
	4,0	10,06	0,52	8,7	10,37	11,98
	4,5	10,06	0,56	9,3	11,00	12,70

3.0 LA	1,7	8,84	0,50	8,3	12,79	14,77
	2,0	9,33	0,54	8,9	12,32	14,23
	2,5	10,10	0,60	10,1	11,84	13,67
	3,0	10,32	0,68	11,3	12,73	14,70
	3,5	10,71	0,74	12,3	12,87	14,86
	4,0	10,97	0,79	13,2	13,17	15,21
	4,5	10,97	0,84	14,0	13,96	16,12

*Recommended operating pressure. Data based on 180°.

T5 RAPIDSET NOZZLE PERFORMANCE DATA

Nozzle	Pressure Bar	Radius m.	Flow m³/hr	Flow l/m	Precipitation Rate (mm/hr)	
					■	▲
1.5	1,7	10,06	0,26	4,4	5,16	5,96
	2,0	10,18	0,28	4,7	5,44	6,29
	2,5	10,40	0,32	5,3	5,90	6,82
	3,0	10,62	0,35	5,9	6,27	7,25
	3,5	10,67	0,38	6,3	6,69	7,73
	4,0	10,76	0,40	6,7	6,99	8,07
	4,5	10,97	0,43	7,1	7,09	8,19
2.0	1,7	10,67	0,33	5,5	5,79	6,68
	2,0	10,79	0,36	6,0	6,20	7,16
	2,5	11,01	0,42	7,0	6,89	7,96
	3,0	11,23	0,47	7,8	7,46	8,62
	3,5	11,28	0,51	8,4	7,94	9,17
	4,0	11,28	0,54	9,0	8,52	9,83
	4,5	11,28	0,59	9,8	9,21	10,64
2.5	1,7	10,67	0,40	6,6	6,98	8,07
	2,0	10,79	0,44	7,3	7,53	8,70
	2,5	11,01	0,51	8,5	8,41	9,71
	3,0	11,23	0,57	9,5	8,99	10,39
	3,5	11,28	0,61	10,2	9,62	11,11
	4,0	11,28	0,65	10,9	10,27	11,86
	4,5	11,28	0,69	11,5	10,89	12,58
3.0 Standard	1,7	10,97	0,50	8,3	8,30	9,58
	2,0	11,22	0,54	8,9	8,52	9,84
	2,5	11,66	0,60	10,1	8,88	10,25
	3,0	12,10	0,68	11,3	9,25	10,68
	3,5	12,19	0,75	12,6	10,15	11,72
	4,0	12,19	0,82	13,6	11,01	12,72
	4,5	12,19	0,86	14,4	11,61	13,41
4.0	1,7	11,28	0,67	11,2	10,54	12,17
	2,0	11,64	0,72	12,1	10,69	12,34
	2,5	12,27	0,82	13,7	10,92	12,61
	3,0	12,71	0,91	15,2	11,30	13,04
	3,5	12,80	0,98	16,3	11,92	13,77
	4,0	12,89	1,04	17,3	12,49	14,42
	4,5	13,11	1,10	18,4	12,83	14,81
5.0	1,7	11,89	0,85	14,2	12,05	13,92
	2,0	12,13	0,92	15,3	12,50	14,44
	2,5	12,57	1,04	17,3	13,15	15,18
	3,0	13,02	1,14	19,0	13,44	15,51
	3,5	13,46	1,24	20,7	13,73	15,86
	4,0	13,72	1,33	22,2	14,14	16,33
	4,5	13,72	1,39	23,1	14,73	17,01
6.0	1,7	11,89	0,95	15,9	13,50	15,59
	2,0	12,38	1,04	17,4	13,65	15,76
	2,5	13,22	1,21	20,1	13,79	15,92
	3,0	13,88	1,35	22,4	13,96	16,12
	3,5	14,20	1,45	24,2	14,42	16,65
	4,0	14,42	1,55	25,9	14,93	17,24
	4,5	14,63	1,65	27,4	15,39	17,77
8.0	1,7	10,97	1,31	21,8	21,69	25,05
	2,0	11,83	1,43	23,8	20,43	23,59
	2,5	13,26	1,64	27,3	18,65	21,54
	3,0	14,14	1,80	29,9	17,96	20,74
	3,5	14,50	1,95	32,4	18,51	21,37
	4,0	14,81	2,08	34,7	18,99	21,93
	4,5	15,24	2,20	36,7	18,97	21,91

Precipitation rates based on half-circle operation

■ Square spacing based on 50% diameter of throw

▲ Triangular spacing based on 50% diameter of throw

Specifying Information — T5 RapidSet Rotors

T5XX XX XX X.X E-RS						
Base Model	Body	Optional	Optional	Custom Nozzles	Optional	
T5	XX	XX	XX	X.X	E	-RS
T5— T5 RapidSet Series Rotor	P - Lawn S - Shrub HP - High Pop	CK — Check Valve	SS — Stainless Steel Riser	1.5-5,9LPM (1.5 gpm) 2.0-7,8LPM (2.0 gpm) 2.5-9,5LPM (2.5 gpm)	E — Effluent	RS — RapidSet

Example: A T5 RapidSet Lawn Pop-up sprinkler with a 2.5 nozzle and Check Valve would be specified as: **T5PCK2.5-RS**

The 1" inlet Toro® T7 Series rotor is built rugged to withstand the performance and durability requirements of municipal/government, sports fields and large commercial settings. Driven by customer feedback, the T7 Series rotor has been designed and tested to ensure consistent performance and features a full 12,7m (5") pop-up height, a visual top-of-rotor arc adjustment dial, and Smart Arc™ Memory that resets the rotor's arc should it be changed due to vandalism or inexperienced users. Further enhancing its versatility, the T7 Series is also available in Low Flow models for smaller radius, lower flow applications, such as baseball infields.



T7 SERIES ROTORS

FEATURES & BENEFITS

Visual Arc Indication

Arc setting indicator on top of the rotor allows for easy wet or dry adjustments from 45°-360°.

High Efficiency Nozzles

Single port design ensures water is evenly distributed across the stream.

Vandal and Abuse Resistance

Smart Arc™ memory safely returns the sprinkler to previously set arc if vandalized. An integrated slip clutch prevents the breaking and stripping of gears.

Design Solutions and Safety

Standard Check-O-Matic Seal prevents low head drainage, and a minimal 2.2" exposed rubber cover diameter reduces the potential for injuries on play areas.

Durability

Heavy-duty retract spring and wiper seal reduce the occurrence of stick-ups and seal leakage, while a water-lubricated gear drive contributes to long-term consistent performance.

Additional Features

- ✓ Standard reversible Check-O-Matic seal
- ✓ Included nozzle trees:
 - Low flow nozzles (2, 3, 4.5, 6, 7.5, and 9)
 - Standard nozzles (7, 9, 12, 16, 20, 24, and 27)
- ✓ Slip clutch
- ✓ Locking cap screw
- ✓ Adjustment/pull up tool included

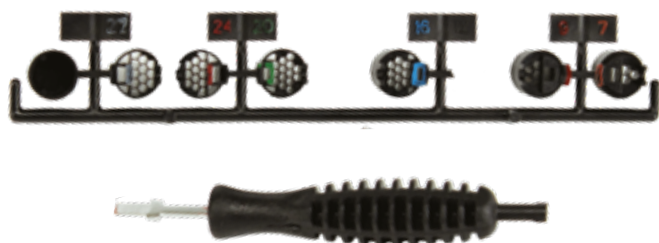

Effluent
Options
Available



Check
Valve
Options
Available



SST Riser
Options
Available



Arc Setting
Visual arc setting dial within rubber cover allows for fast and easy arc adjustments.



SPECIFICATIONS

Operational

- Radius capability:
 - Low flow models—11,6-17,1 m
 - Standard models—14,0-22,9 m
- Flow rates:
 - Low flow models—6,5-48,2 LPM
 - Standard models—25,0-115,5 m
- Operating pressure range: 2,8 - 6,9 Bar
- Recommended operating pressure: 4,1-4,8 Bar
- Inlet size: 1" female BSP
- Nozzle trajectory: 25°
- Arc adjustment: 45°-360° (unidirectional at 360°)

Dimensions

- Pop-up height (measured from top of cap to nozzle): 127mm (5")
- Body height: 220mm (8.8")
- Body diameter: 70mm (2.7")
- Rubber cover diameter: 57mm (2.2")

Available Options

- Stainless Steel riser
- Effluent Lavender rubber cover

Warranty

- Five years

T7 SPORTS ROTOR NOZZLE PERFORMANCE DATA HIGH FLOW

Nozzle	Pressure (Bar)	Flow (LPM)	Radius (m)	Precip mm/hr ■	Precip mm/hr ▲
7.0	2,8	25,8	14,1	7,87	8,97
	3,4	28,1	14,8	8,21	9,36
	4,1	30,7	14,9	8,60	9,81
	4,8	33,7	15,3	9,07	10,34
	5,5	36,6	15,8	9,09	10,37
	6,2	38,9	15,8	9,29	10,59
9.0	6,9	41,1	16,3	9,10	10,37
	2,8	28,5	14,4	8,35	9,52
	3,4	31,2	15,4	8,07	9,20
	4,1	33,7	15,3	8,38	9,55
	4,8	37,1	15,8	8,87	10,12
	5,5	39,7	16,4	8,80	10,04
12.0	6,2	42,4	16,3	9,06	10,33
	6,9	44,8	16,5	9,23	10,52
	2,8	37,7	15,3	9,74	11,10
	3,4	39,9	16,3	9,92	11,32
	4,1	43,6	17,3	10,04	11,45
	4,8	47,5	18,0	10,52	11,99
16.0	5,5	51,1	18,2	10,92	12,45
	6,2	54,4	18,5	11,22	12,79
	6,9	57,5	19,2	11,43	13,03
	2,8	50,8	16,0	11,68	13,32
	3,4	56,6	17,4	11,67	13,30
	4,1	59,8	18,3	11,48	13,09
20.0	4,8	64,8	18,6	12,03	13,72
	5,5	69,7	19,4	12,10	13,80
	6,2	74,3	19,6	12,50	14,25
	6,9	78,7	20,0	12,82	14,62
	2,8	61,0	15,8	14,02	15,99
	3,4	69,7	17,5	13,38	15,26
24.0	4,1	74,1	18,6	13,29	15,16
	4,8	79,5	19,4	13,81	15,75
	5,5	85,5	20,2	13,07	14,90
	6,2	90,8	20,7	13,47	15,36
	6,9	95,7	21,4	13,78	15,71
	2,8	58,5	16,4	13,99	15,95
27.0	3,4	67,0	18,4	12,02	13,70
	4,1	74,8	19,4	12,18	13,88
	4,8	81,8	20,2	12,51	14,27
	5,5	88,2	20,8	12,69	14,47
	6,2	94,2	21,3	13,16	15,00
	6,9	99,6	22,0	12,76	14,55
27.0	2,8	73,3	16,8	15,66	17,86
	3,4	83,2	19,6	12,72	14,51
	4,1	90,2	21,6	11,56	13,18
	4,8	97,2	22,0	12,11	13,81
	5,5	103,5	22,3	12,55	14,31
	6,2	109,9	22,7	12,97	14,79
6,9	115,5	22,9	13,27	15,13	

T7 SPORTS ROTOR NOZZLE PERFORMANCE DATA LOW FLOW

Nozzle	Pressure (Bar)	Flow (LPM)	Radius (m)	Precip mm/hr ■	Precip mm/hr ▲
2.0	2,8	6,5	12,2	2,78	3,17
	3,4	7,4	12,8	3,15	3,59
	4,1	8,2	12,8	3,32	3,78
	4,8	8,9	12,5	3,61	4,11
	5,5	9,6	12,8	3,88	4,43
	6,2	10,3	12,5	3,94	4,50
3.0*	6,9	10,9	12,5	4,19	4,78
	2,8	9,2	12,5	3,91	4,46
	3,4	10,5	12,8	4,23	4,83
	4,1	11,7	12,5	4,51	5,14
	4,8	12,8	12,5	4,92	5,61
	5,5	13,8	12,8	5,05	5,76
4.5	6,2	14,7	12,5	5,15	5,87
	6,9	15,4	13,1	5,37	6,12
	2,8	15,4	11,6	6,89	7,86
	3,4	17,6	12,5	6,77	7,72
	4,1	19,6	12,5	7,52	8,58
	4,8	21,3	12,8	7,82	8,92
6.0	5,5	23,0	12,8	8,43	9,61
	6,2	24,6	13,1	8,59	9,79
	6,9	26,0	13,1	9,10	10,38
	2,8	18,6	13,1	6,51	7,42
	3,4	21,3	14,0	6,51	7,42
	4,1	23,7	14,6	6,66	7,59
7.5	4,8	26,7	15,2	7,18	8,19
	5,5	27,9	14,9	7,51	8,56
	6,2	29,8	15,2	7,70	8,78
	6,9	31,7	15,2	8,19	9,34
	2,8	21,9	13,4	7,30	8,33
	3,4	25,1	14,0	7,66	8,74
9.0	4,1	27,9	14,6	7,82	8,92
	4,8	30,5	15,2	8,20	9,35
	5,5	33,0	15,5	8,54	9,74
	6,2	35,8	15,8	9,26	10,55
	6,9	37,4	15,8	8,95	10,20
	2,8	27,7	13,7	8,85	10,10
9.0	3,4	31,9	14,9	8,60	9,80
	4,1	35,5	15,5	8,83	10,07
	4,8	39,5	16,5	9,08	10,36
	5,5	42,7	16,8	9,11	10,39
	6,2	45,6	16,8	9,74	11,11
	6,9	48,2	17,1	9,94	11,33

When the sprinkler is adjusted to 360°, it will be uni-directional in that direction of rotation (clockwise or counterclockwise) at the moment when the sprinkler was changed to 360°
* Pre-installed nozzle. Data based on 180°.

Specifying Information—T7 Series Rotors

T7PXX-52XX			
Description	Optional	Thread	Optional
T7P	XX	52	XX
T7 Series Rotor	SS-Stainless Steel Riser	52—BSP	E—Effluent L—Low Flow
Example: A low flow T7 Series rotor with a Stainless Steel riser and Effluent rubber cover would be specified as: T7PSS-52LE			

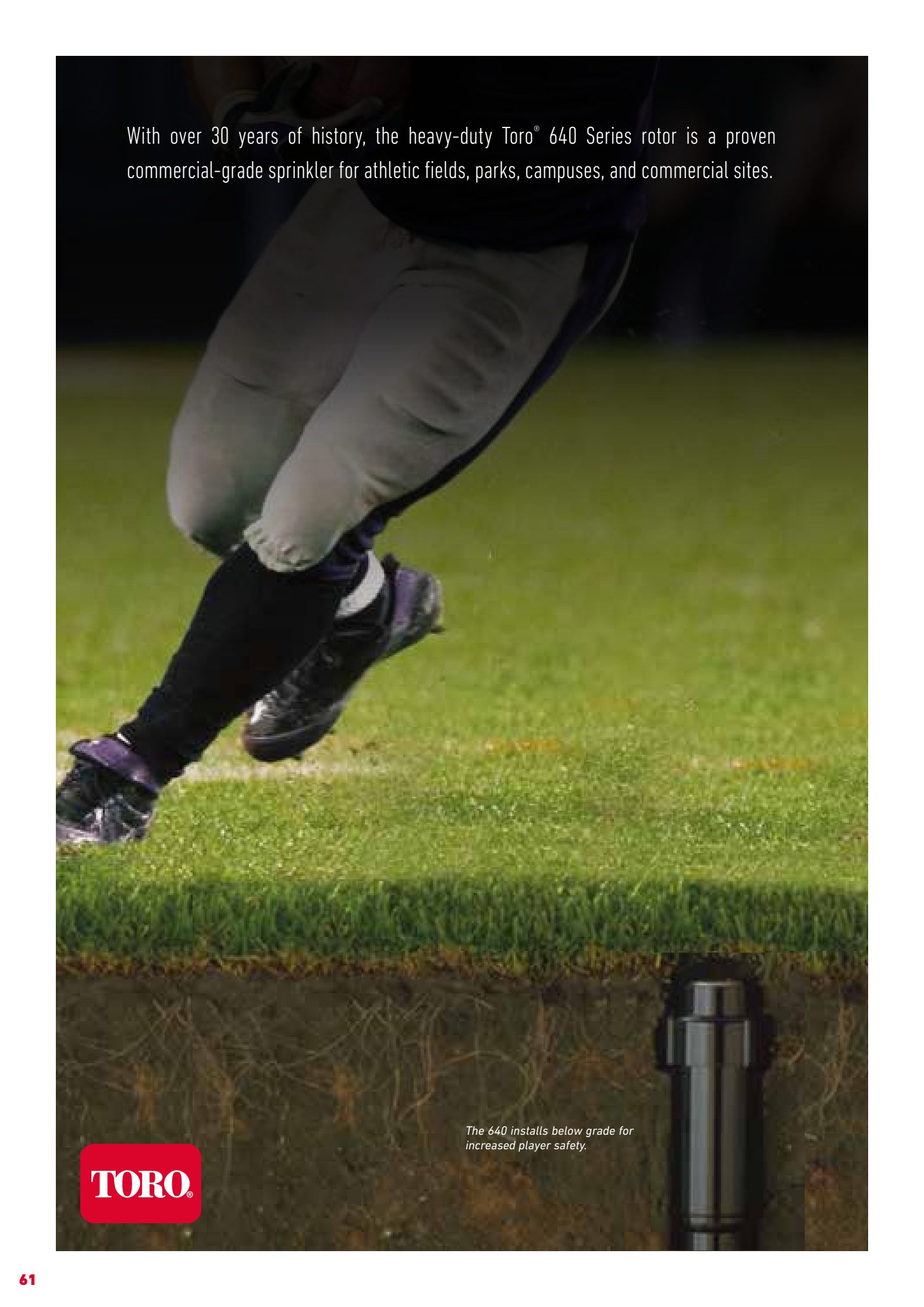
A photograph of a baseball player in mid-stride on a green field. The player is wearing a dark jersey, grey pants, black socks, and purple cleats. The background is dark, suggesting a night game. In the bottom right corner, a cross-section of the ground shows a black Toro 640 rotor sprinkler installed underground. The sprinkler is a vertical, cylindrical device with a cap at the top and a base at the bottom, positioned in a hole in the soil.

With over 30 years of history, the heavy-duty Toro® 640 Series rotor is a proven commercial-grade sprinkler for athletic fields, parks, campuses, and commercial sites.

The 640 installs below grade for increased player safety.

TORO®

640 SERIES ROTORS

FEATURES & BENEFITS

Normally Open Valve-In-Head Body

Allows individual head control - the only commercial grade Toro rotor available with this feature.

Standard Check Valve

Prevents low head drainage and keeps laterals charged with water.

Additional Features

- ✓ Standard rubber cover
- ✓ Vandal-resistant cap with locking set screw
- ✓ Small exposed surface diameter
- ✓ Basket filter screen



Effluent
Options
Available



Check
Valve
Options
Available

640 SERIES PERFORMANCE DATA

Nozzle	Pressure (Bar)	Flow (LPM)	Radius (M)	360°		270°		238°		192°		180°		173°	
				▲	■	▲	■	▲	■	▲	■	▲	■	▲	■
40	3.0	23.6	14.6	7.62	6.60	10.16	8.81	11.53	9.99	14.29	12.38	15.24	13.21	15.86	13.74
	3.5	25.5	15.3	7.62	6.60	10.16	8.81	11.53	9.99	14.29	12.38	15.24	13.21	15.86	13.74
	4.0	27.1	15.8	7.52	6.55	10.02	8.74	11.37	9.91	14.10	12.29	15.04	13.11	15.65	13.64
	4.5	29.2	16.0	8.01	6.74	10.68	8.98	12.11	10.19	15.01	12.63	16.01	13.47	16.66	14.02
	5.0	30.9	16.2	8.19	6.92	10.92	9.23	12.39	10.47	15.36	12.98	16.38	13.84	17.05	14.40
	5.5	32.6	16.5	8.38	7.11	11.18	9.48	12.68	10.76	15.72	13.34	16.76	14.22	17.44	14.80
6.0	34.7	16.7	8.56	7.29	11.41	9.72	12.95	11.03	16.05	13.67	17.12	14.58	17.81	15.17	
41	3.0	36.9	15.2	11.15	9.72	14.87	12.95	16.87	14.70	20.91	18.22	22.30	19.43	23.20	20.22
	3.5	38.8	16.2	10.20	8.91	13.60	11.88	15.43	13.48	19.12	16.70	20.40	17.82	21.22	18.54
	4.0	41.0	16.4	10.57	9.04	14.09	12.06	15.98	13.68	19.81	16.95	21.13	18.08	21.99	18.82
	4.5	43.6	16.6	11.06	9.53	14.74	12.71	16.72	14.42	20.73	17.87	22.11	19.06	23.01	19.83
	5.0	46.1	16.8	11.24	9.72	14.99	12.95	17.00	14.70	21.07	18.22	22.48	19.43	23.39	20.22
	5.5	48.1	17.1	11.43	9.91	15.24	13.21	17.29	14.98	21.43	18.57	22.86	19.81	23.78	20.61
6.0	49.9	17.3	11.61	10.08	15.48	13.45	17.56	15.25	21.76	18.91	23.22	20.17	24.15	20.98	
42	3.0	46.6	16.2	12.27	10.74	16.36	14.33	18.56	16.25	23.00	20.15	24.54	21.49	25.53	22.36
	3.5	49.1	16.8	12.00	10.45	15.99	13.94	18.14	15.81	22.49	19.60	23.99	20.90	24.96	21.75
	4.0	52.5	17.0	12.70	10.87	16.93	14.49	19.21	16.44	23.81	20.38	25.40	21.74	26.43	22.62
	4.5	53.7	17.2	12.46	11.06	16.61	14.74	18.85	16.72	23.36	20.73	24.92	22.11	25.93	23.01
	5.0	57.0	17.7	12.45	11.18	16.59	14.90	18.83	16.90	23.34	20.96	24.89	22.35	25.90	23.26
	5.5	59.8	17.7	13.21	11.43	17.61	15.24	19.98	17.29	24.77	21.43	26.42	22.86	27.48	23.78
6.0	62.5	17.7	13.92	11.96	18.56	15.95	21.05	18.10	26.10	22.43	27.84	23.93	28.96	24.89	
43	3.0	51.7	17.4	11.85	10.33	15.80	13.77	17.92	15.62	22.22	19.36	23.70	20.65	24.66	21.49
	3.5	55.2	18.0	11.76	10.22	15.68	13.62	17.79	15.45	22.05	19.16	23.52	20.43	24.47	21.26
	4.0	58.4	17.9	12.65	10.87	16.87	14.49	19.13	16.44	23.72	20.38	25.30	21.74	26.32	22.62
	4.5	62.0	18.3	12.95	11.18	17.27	14.90	19.59	16.90	24.29	20.96	25.91	22.35	26.96	23.26
	5.0	66.2	19.0	12.57	11.18	16.76	14.90	19.02	16.90	23.57	20.96	25.15	22.35	26.16	23.26
	5.5	69.3	19.2	12.95	11.18	17.27	14.90	19.59	16.90	24.29	20.96	25.91	22.35	26.96	23.26
6.0	72.2	19.4	13.31	11.53	17.75	15.38	20.13	17.44	24.96	21.62	26.62	23.06	27.70	24.00	
44	3.0	65.7	17.3	15.14	13.20	20.18	17.59	22.90	19.96	28.38	24.74	30.28	26.39	31.50	27.46
	3.5	70.8	18.3	14.52	12.74	19.35	16.98	21.96	19.27	27.22	23.88	29.03	25.48	30.21	26.51
	4.0	73.8	18.5	14.88	13.16	19.85	17.54	22.51	19.90	27.91	24.67	29.77	26.31	30.97	27.38
	4.5	80.2	18.9	15.37	13.46	20.50	17.95	23.25	20.36	28.83	25.24	30.75	26.92	31.99	28.01
	5.0	84.0	19.4	15.75	13.46	21.00	17.95	23.82	20.36	29.53	25.24	31.50	26.92	32.77	28.01
	5.5	88.6	19.8	15.75	13.46	21.00	17.95	23.82	20.36	29.53	25.24	31.50	26.92	32.77	28.01
6.0	92.8	20.2	15.75	13.64	21.00	18.19	23.82	20.63	29.53	25.57	31.50	27.28	32.77	28.38	

Nozzle	Pressure (Bar)	Flow (LPM)	Radius (M)	148°		127°		108°		90°		60°		45°	
				▲	■	▲	■	▲	■	▲	■	▲	■	▲	■
40	3.0	23.6	14.6	18.54	16.06	21.60	18.72	25.40	22.01	30.48	26.42	45.72	39.62	60.96	52.83
	3.5	25.5	15.3	18.54	16.06	21.60	18.72	25.40	22.01	30.48	26.42	45.72	39.62	60.96	52.83
	4.0	27.1	15.8	18.29	15.94	21.31	18.58	25.06	21.84	30.07	26.21	45.11	39.32	60.15	52.43
	4.5	29.2	16.0	19.48	16.39	22.70	19.10	26.69	22.46	32.03	26.95	48.04	40.42	64.06	53.90
	5.0	30.9	16.2	19.93	16.84	23.22	19.62	27.31	23.07	32.77	27.69	49.15	41.53	65.53	55.37
	5.5	32.6	16.5	20.39	17.30	23.76	20.16	27.94	23.71	33.53	28.45	50.29	42.67	67.06	56.90
6.0	34.7	16.7	20.82	17.73	24.26	20.66	28.53	24.30	34.24	29.16	51.36	43.74	68.48	58.32	
41	3.0	36.9	15.2	27.12	23.63	31.61	27.54	37.17	32.39	44.60	38.86	66.90	58.29	89.20	77.72
	3.5	38.8	16.2	24.81	21.67	28.91	25.25	33.99	29.70	40.79	35.64	61.19	53.45	81.58	71.27
	4.0	41.0	16.4	25.70	22.00	29.95	25.63	35.22	30.14	42.27	36.17	63.40	54.25	84.53	72.34
	4.5	43.6	16.6	26.89	23.18	31.34	27.02	36.85	31.77	44.22	38.13	66.33	57.19	88.44	76.25
	5.0	46.1	16.8	27.34	23.63	31.86	27.54	37.47	32.39	44.96	38.86	67.44	58.29	89.92	77.72
	5.5	48.1	17.1	27.80	24.10	32.40	28.08	38.10	33.02	45.72	39.62	68.58	59.44	91.44	79.25
6.0	49.9	17.3	28.24	24.53	32.90	28.58	38.69	33.61	46.43	40.34	69.65	60.50	92.86	80.67	
42	3.0	46.6	16.2	29.84	26.13	34.78	30.46	40.89	35.81	49.07	42.98	73.61	64.47	98.15	85.95
	3.5	49.1	16.8	29.18	25.42	34.00	29.63	39.98	34.84	47.98	41.81	71.97	62.71	95.96	83.62
	4.0	52.5	17.0	30.89	26.44	36.00	30.82	42.33	36.24	50.80	43.48	76.20	65.23	101.60	86.97
	4.5	53.7	17.2	30.30	26.89	35.32	31.34	41.53	36.85	49.83	44.22	74.75	66.33	99.67	88.44
	5.0	57.0	17.7	30.27	27.18	35.28	31.68	41.49	37.25	49.78	44.70	74.68	67.06	99.57	89.41
	5.5	59.8	17.7	32.13	27.80	37.44	32.40	44.03	38.10	52.83	45.72	79.25	68.58	105.66	91.44
6.0	62.5	17.7	33.86	29.10	39.46	33.91	46.40	39.88	55.68	47.85	83.52	71.78	111.35	95.71	
43	3.0	51.7	17.4	28.82	25.12	33.59	29.27	39.50	34.42	47.40	41.30	71.09	61.95	94.79	82.60
	3.5	55.2	18.0	28.61	24.85	33.34	28.96	39.20	34.06	47.04	40.87	70.56	61.30	94.08	81.74
	4.0	58.4	17.9	30.77	26.44	35.86	30.82	42.16	36.24	50.60	43.48	75.90	65.23	101.19	86.97
	4.5	62.0	18.3	31.51	27.18	36.72	31.68	43.18	37.25	51.82	44.70	77.72	67.06	103.63	89.41
	5.0	66.2	19.0	30.58	27.18	35.64	31.68	41.91	37.25	50.29	44.70	75.44	67.06	100.58	89.41
	5.5	69.3	19.2	31.51	27.18	36.72	31.68	43.18	37.25	51.82	44.70	77.72	67.06	103.63	89.41
6.0	72.2	19.4	32.37	28.05	37.73	32.69	44.37	38.44	53.24	46.13	79.86	69.19	106.48	92.25	
44	3.0	65.7	17.3	36.82	32.10	42.91	37.40	50.46	43.98	60.55	52.78	90.83	79.17	121.11	105.56
	3.5	70.8	18.3	35.31	30.98	41.15	36.11	48.39	42.46	58.06	50.95	87.10	76.43	116.13	101.90
	4.0	73.8	18.5	36.21	32.00	42.19	37.30	49.61	43.86	59.54	52.63	89.31	78.94	119.08	105.26
	4.5	80.2	18.9	37.39	32.75	43.58	38.16	51.24	44.87	61.49	53.85	92.24	80.77	122.99	107.70
	5.0	84.0	19.4	38.31	32.75	44.64	38.16	52.49	44.87	62.99	53.85	94.49	80.77	125.98	107.70
	5.5	88.6	19.8	38.31	32.75	44.64	38.16	52.49	44.87	62.99	53.85	94.49	80.77	125.98	107.70
6.0	92.8	20.2	38.31	33.18	44.64	38.66	52.49	45.47	62.99	54.56	94.49	81.84	125.98	109.12	

Precipitation Rate Data in mm/HR
 ▲ Precipitation rates are for triangular spacing, shown in millimeters per hour, calculated at 50% of diameter.
 ■ Precipitation rates are for square spacing, shown in millimeters per hour, calculated at 50% of diameter.
 All performance specifications are based on the stated working pressure available at the base of the sprinkler.
 Radius shown in meters. Data based on 360°.
 Note: For the 640, differing arcs cannot be valved together.

SPECIFICATIONS

Operational

- Radius: 14-20m
- Flow Rate: 22,7-94,6LPM
- Operating Pressure Range: 2,8-6,2Bar
- Trajectory: 27°
- Pop-up to nozzle: 60mm
- Inlet: 1" female-threaded
- Below-grade installation: up to 13mm
- Check-O-Matic maintains up to 14,6m elevation change
- Selection of five nozzles and 12 arcs
- Adjustment screw allows up to 25% radius reduction
- Rotation speed at 360° for the fast-rotating drive is 40 seconds

Dimensions

- Body diameter: 63mm
- Cap diameter: 81mm
- Body height:
 - Check-O-Matic – 230mm
 - Valve-In-head – 267mm
- Exposed surface diameter when buried
 - 13mm below grade: 45mm

Options Available

- Valve-In-Head Snap Ring Pliers (995-100)
- Valve Removal Tool (995-08)
- #41 Fast Rotating Stator (35-0579)

Warranty

- Five years

640 SERIES MODEL LIST

Model	Description
BODY PACKAGE	
640-52	640 Body Package, VIH Check-O-Matic, BSP
640-51	641 Body Package, Normally Open VHI, BSP
NOZZLE/STATOR SET	
640-40	#40 Nozzle and Stator
640-41	#41 Nozzle and Stator
640-42	#42 Nozzle and Stator
640-43	#43 Nozzle and Stator
640-44	#44 Nozzle and Stator
640-40E	#40 Nozzle & Stator, Effluent
640-41E	#41 Nozzle & Stator, Effluent
640-42E	#42 Nozzle & Stator, Effluent
640-43E	#43 Nozzle & Stator, Effluent
640-44E	#44 Nozzle & Stator, Effluent

Model	Description
DRIVE ASSEMBLY	
640-0045	640 Drive Assembly, 45 degrees
640-0060	640 Drive Assembly, 60 degrees
640-0090	640 Drive Assembly, 90 degrees
640-0108	640 Drive Assembly, 108 degrees
640-0127	640 Drive Assembly, 127 degrees
640-0148	640 Drive Assembly, 148 degrees
640-0173	640 Drive Assembly, 173 degrees
640-0180	640 Drive Assembly, 180 degrees
640-0192	640 Drive Assembly, 192 degrees
640-0238	640 Drive Assembly, 238 degrees
640-0270	640 Drive Assembly, 270 degrees
640-0360	640 Drive Assembly, 360 degrees

Specifying Information—640 Series Rotors (Assembled Rotors)

64X-XX-XX				
Arc	Thread	Valve Type	Nozzle	Optional
64X	X	X	XX	E
0—Special Arc 1—90° 2—180° 3—270° 4—360°	5—BSP Thread	1—Normally Open Valve-In-Head 2—Check-O-Matic	41 - #41 Nozzle 42 - #42 Nozzle 43 - #43 Nozzle 44 - #44 Nozzle	E—Effluent Model
Example: A 640 Series Sprinkler with a 90° arc, 40 nozzle and a check valve, would be specified as: 641-02-40				

Most 640 sprinklers are available in component parts only. Consult Res/Com Finished Goods Price List for a complete list of sprinklers available as finished goods.

For big open spaces, the Toro® TS90 provides unparalleled features and performance into a fully adjustable rotor. Designed for large turf areas, its radius of 16,2 to 29,0 m is ideal for parks, sports fields, synthetic turf athletic fields and horse arenas. In addition, Toro patented TruJectory™ allows for the fine tuning of nozzle spray height from 7-30° to ensure wind resistance and head-to-head spacing.



TS90 SERIES ROTORS

FEATURES & BENEFITS

TruJectory™ Adjustment from 7° to 30°

Fine tunes nozzle spray height, helps provide true head-to-head coverage, and compensates for windy conditions.

Part- and Full-Circle in One Sprinkler

No need to inventory multiple models or service parts

Back Nozzle Capable

Perfect for perimeter of sports fields. Provides the flexibility for fine-tuning any watering requirement.

Ratcheting Riser

Allows you to adjust the riser position in the body without disassembling. Simply pull up the riser and ratchet it to the precise position you want to water.

Three Nozzle Configuration

Provides better distribution uniformity, nozzle flexibility and system efficiency.

Constant-Velocity Drive

Provides reliable rotation speed – from sprinkler to sprinkler.

TurfCup™ for Sports Fields

The optional TurfCup version seamlessly integrates into either natural grass or artificial turf sports fields, enhancing player safety, surface playability and field aesthetics.



Effluent
Options
Available



Check
Valve
Options
Available

SPECIFICATIONS

Operational

- Radius: 16,2-29,0 m at 25° trajectory
- Flow Rate: 52,9-232,8 LPM
- Precipitation Rate: 14,2-15,2 mm/hr
- Arc: Full- and Part-circle in one
 - Full-circle: 360° unidirectional rotation
 - Part-circle: 40°-330°
- Rotation Speed: 3 minutes ± 30 seconds (360°)
- Inlet: 1" female-threaded BSP
- Operating pressure range: 2,8-7,0 Bar

Dimensions

- Body Height: 254mm
- Overall Height: 317mm
- Retracted Height: 216mm
- Pop-Up Height: 100mm
- Exposed Cap Diameter: 57mm

Warranty

- Five years

Options Available

- Nozzle, #9 Main (102-4259)
- Effluent Cap Marker (118-0063)
- Main Nozzle Tool: (995-99)
- Intermediate nozzle and TruJectory™ tool (995-105)

Additional Features

- ✓ Full set of color-coded nozzles that thread directly into the nozzle port
- ✓ Rubber cover and below grade installation
- ✓ Check Valve standard – maintains up to 3m elevation
- ✓ Nozzle options: nine main, three intermediate, one inner



TS90 SERIES MODEL LIST

Model	Description
TS90TP-52	1" BSP, Nozzles 1-9 included
TS90TP-52TC	1" BSP with Turf Cup, Nozzles 1-9 included

TS90TP NOZZLE PERFORMANCE DATA

Nozzle Set		Stator	3,4 Bar		4,1 Bar		4,8 Bar		5,5 Bar		6,2 Bar		6,9 Bar	
Number	Main/Intermediate		Radius (m)	Flow (LPM)	Radius (m)	Flow (LPM)	Radius (m)	Flow (LPM)	Radius (m)	Flow (LPM)	Radius (m)	Flow (LPM)	Radius (m)	Flow (LPM)
1	Yellow/Blue	102-1939 Yellow	16,2	53	16,5	58	16,8	62	16,8	66	16,5	70	17,1	74
2	Blue/Red		16,8	71	18,0	78	18,6	84	18,0	89	18,0	95	18,9	100
3	Brown/Orange		-	-	17,4	86	18,3	93	18,6	99	19,2	105	20,7	110
4	Orange/Orange		-	-	-	-	22,6	124	24,4	133	24,7	140	25,0	147
5	Green/Blue	102-1940 White	-	-	-	-	-	-	24,1	143	25,0	151	25,6	158
6	Gray/Blue		-	-	-	-	-	-	25,0	150	26,2	159	26,5	167
7	Black/Orange		-	-	-	-	-	-	24,4	165	26,5	175	25,6	184
8	Red/Blue		-	-	-	-	-	-	26,2	184	26,8	195	26,8	205
9	Beige/Blue	102-1941 White	-	-	-	-	-	-	25,9	208	27,7	221	29,0	233

Specifying Information—TS90TP Series

TS90TP52-XX-X					
Arc	Threads	TurfCup™	Nozzle		Optional
TS90TP	XX		X		E
TS90TP— TS90TP 25mm (1") Rotor with TruJectory	52—BSP	TC—TurfCup Option	1	4	7
			2	5	8
			3	6	9
			E—Effluent Model		

Example: A TS90 Series sprinkler with TruJectory, BSP threads, and with an #8 nozzle would be specified as: **TS90TP-52-8**

For nearly 40 years the 690 series has set the standard for durability and reliability in commercial applications. Extremely rugged, the 690 Series is constructed of brass, stainless steel and engineering plastics for unmatched performance in the most demanding environments.



TORO

690 SERIES ROTORS

FEATURES & BENEFITS

Artificial Playing Surfaces

Radius and flow capabilities are perfect for cooling and rinsing artificial playing surfaces such as football fields

Electric Valve In Head Models

Provide individual head control that ensures run times can match differing soil, turf and terrain watering requirements, pressure regulation to ensure all nozzles perform at the same pressure and manual ON-OFF-auto control at the head.

Fixed Arc Drives

Nine fixed arc drive assemblies ensure positive retention of the coverage area with no arc drift

Balanced Application Rate

Used in single or double row applications these sprinklers operate at a slower speed over the non-overlap area and a faster speed over the overlapped areas to provide a balanced application rate.



Effluent
Options
Available



Check
Valve
Options
Available

SPECIFICATIONS

Operational

- Radius: 26,5-33,0m
- Flow Rate: 193,0-311,2 LPM
- Operating Pressure Range: 5,5-10,3 Bar
- Pop-up height to nozzle: 20mm (¾")
- Inlet: NPT (1½")
- Check-0-Matic: Maintains 11,2m of elevation

Dimensions

- Body diameter: 254mm
- Body height: 405mm

Warranty

- Three years

Options Available

- Electric Valve-in-head Solenoid: 24VAC, 50/60Hz
 - Inrush: 60 Hz, 0.30 amps
 - Holding: 60 Hz, 0.20 amps

690 SERIES MODEL LIST

Model	Description
690	90° Part-circle sprinkler
691	180° Part-circle sprinkler
694	Full-circle sprinkler
696	2-speed (60°-120°) sprinkler
698	2-speed (180°-180°) sprinkler

690 SERIES PERFORMANCE DATA

Base Pressure			Nozzle Set 90				Nozzle Set 91				Nozzle Set 92			
Bar	kPa	Kg/cm2	Rad.	LPM	Prec. Rate		Rad.	LPM	Prec. Rate		Rad.	LPM	Prec. Rate	
5,5	550	5,61	26,5	193	19,0	16,5	29,3	232	18,7	16,2	30,5	280	20,8	18,0
6,9	690	7,04	27,4	216	19,9	17,2	30,5	278	20,7	17,9	32,9	311	19,9	17,2

Specifying Information—690

69X-0X-XX-X					
Arc		Valve-In-Head Type		Nozzle	Pressure Regulation*
69X		0X		XX	X
0—90°	4—Full-circle	A—150°	1—Normally Open Hydraulic	90	8—80 psi
1—180°	6—Full-circle, 2-speed (60°-120°)	B—165°	2—Check-0-Matic	91	1—100 psi
	8—Full-circle, 2-speed (180°-180°)	C—195°	6—Electric	92	
		D—210°			

Example: When specifying a 690 Series Sprinkler with a 180° arc, electric valve-in-head, #91 nozzle, and pressure regulation at 5,5 Bars (80 psi), you would specify: **692-06-918**

*Electric models only.

ROTOR ACCESSORIES

EFFLUENT WATER INDICATORS FOR 300 SERIES



- 89-7854**
- Lavender cover for 300 Series Omni nozzle high-pop models
 - Use with part no. 300-25 (Omni Nozzle)



- 89-7853**
- Lavender cover for 300 Series Omni nozzle lawn and shrub models
 - Use with part no. 300-15 (Omni Nozzle)



- 89-7889**
- Lavender cap for 300 Series standard lawn and shrub models
 - Use with nozzle assy (01, 02, 03, 63, 93)

NOZZLES



- 102-2633**
- Standard T7 Nozzle Tree

- 102-1877**
- Low Flow T7 Nozzle Tree



- T5 Nozzle Tree Kit**
- 102-7712**
- 20 nozzle trees per bag



- 118-3832**
- T5 Effluent Cap

INSTALLATION/ADJUSTMENT TOOLS



- 102-2024**
- Mini 8 Adjustment Tool



- T5 Rotor Check Valve Kit**
- 102-7714**
- 20 valve seals per bag



- 102-6527**
- T5, T7 and TS90 Rotor Adjustment Tool



- 995-51**
- Pressure gauge kit



- 995-50**
- Pilot tube



- 995-49**
- 0-200 psi pressure gauge hermetically sealed shake resistant-free



- 995-01**
- Flow gauge

INSTALLATION/ADJUSTMENT TOOLS FOR 640 SERIES



- 995-08**
- Valve removal tool
 - Designed for quick removal of valve assembly from body



- 995-33**
- 1/16" Allen screwdriver



- 995-42**
- Canister removal tool for 640 Series models



- 996-51**
- Cap removal tool for 640 Series models



- 995-35**
- Valve insertion tool for 640 Series models
 - Designed for accurate one-step insertion of valve assembly and snap ring

VALVES

A critical part of any irrigation system, Toro® valves are available in a wide variety of sizes, materials and options to meet the most demanding needs.

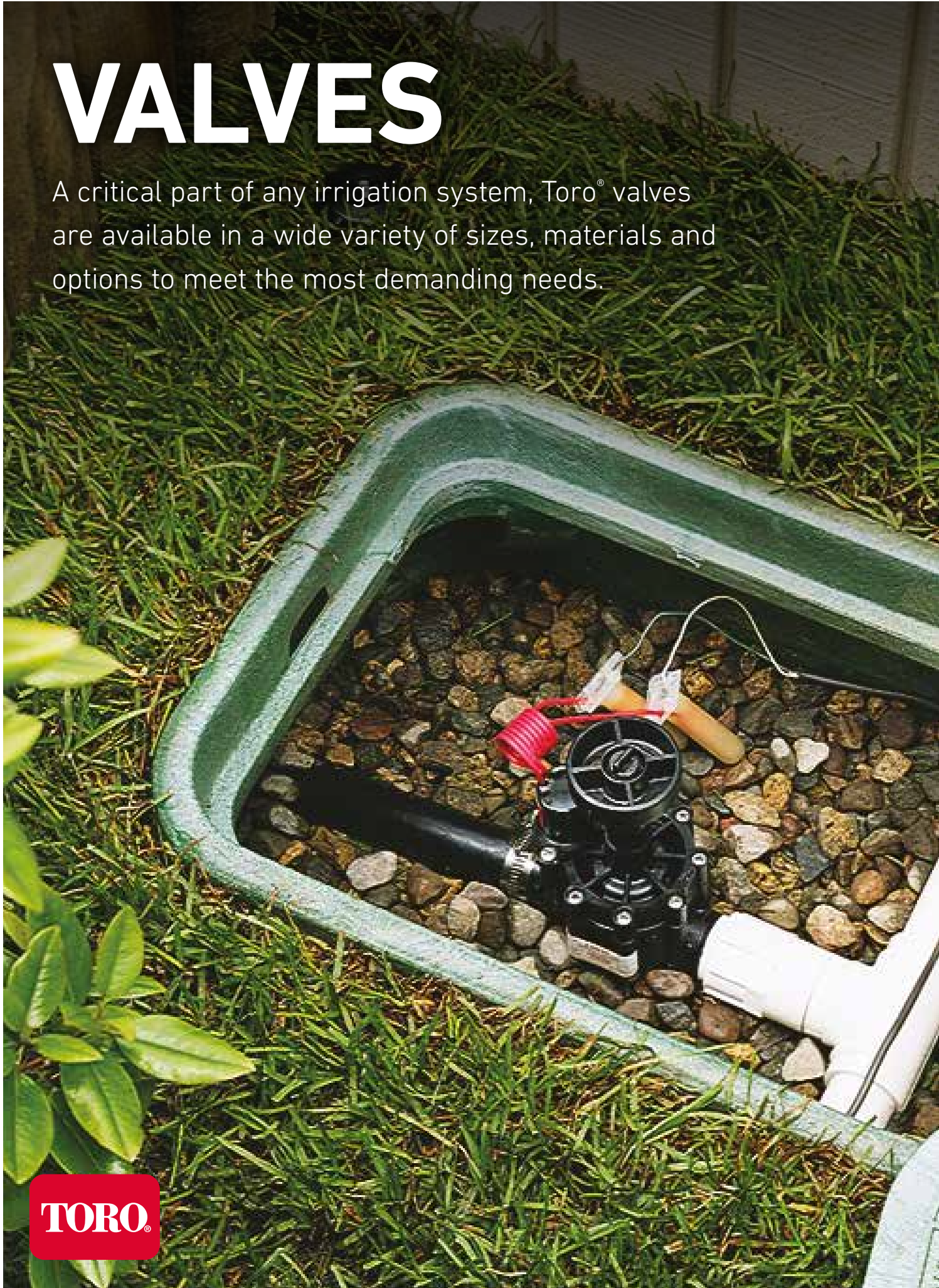

TORO®



VALVES

Pages 73-92

EZ-Flo® Plus Series	75-76
TPV Series	77-78
264 Series	79-80
P150 Series	81-82
252 Series	83-84
P-220 Series	85-86
P-220S Scrubber Series	87-88
220 Brass Series	89-90
Quick Coupler Series	91
Valve Accessories	92

EZ-FLO® PLUS SERIES VALVES



The name says it all. Easy to install, and even easier to service, Toro® EZ-Flo® Plus Series valves are available in a comprehensive range of in-line or anti-siphon configurations that provide design and retrofit flexibility for any residential application. The EZ-Flo valves' heavy duty jar top designs make servicing fast and simple without the need for removing screws or fasteners. Constructed of corrosion and UV-resistant commercial grade PVC and glass-filled polypropylene, all EZ-Flo Series valves feature double-beaded chloramine- and ozone-resistant leak-proof diaphragms, manual external bleed screws, and fully encapsulated solenoids. Robust construction, reliable operation, and jar-top designs that make for tool-free access for servicing – it couldn't be easier.



FEATURES & BENEFITS

Jar-Top Design

No screws or fasteners means fast and easy servicing without the need for tools.

PVC, Glass-Filled Polypropylene and Stainless Steel Construction

Helps provide longer service life and leak protection in nearly any environment.

Double-beaded, Chloramine- and Ozone-Resistant Diaphragm

Ensures a consistent, leak-proof seal up to 10,3 Bar.

In-Line or Anti-Siphon Models

Comprehensive range of options for new or retrofit installations.



Effluent
Options
Available



DC Latching
Solenoid
Option

SPECIFICATIONS

Operational

- Flow Range: 0,9-113,5 LPM
- Operating Pressure: 0,68-10,3 Bar
- Encapsulated solenoid with captured hex plunger, 24 Vac (118-5983):
 - Inrush current, 0.4 amps
 - Holding current, 0.2 amps

Dimensions

- Female Globe: 30 x 75 x 101mm (H x W x L)
- Male Globe: 130 x 75 x 140mm (H x W x L)
- Anti-Siphon: 52 x 75 x 175mm (H x W x L)

Warranty

- Two years

Available Parts & Accessories

- Potted DC Latching Solenoid (DCLS-P)
- Effluent Solenoid Assembly and Tag (EFF-KIT-50HZ)

PRODUCT HIGHLIGHT

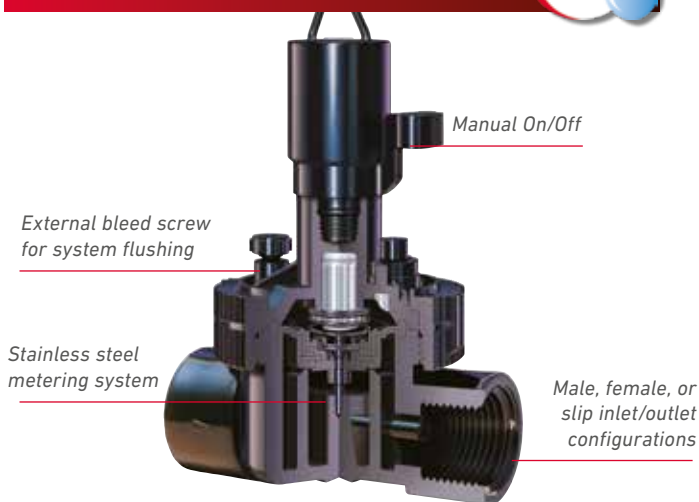

PRESSURE LOSS DATA (measured in pressure loss, LPM)

Size	Model	LPM Flow					
		1	19	38	57	76	114
1"	In-line	0,14	0,24	0,28	0,31	0,32	0,43
1"	Anti-siphon	0,14	0,14	0,31	0,16	0,26	0,56

Flow Control

The precise flow control with ergonomic handle allows fine tuning of the downstream pressure to prevent high pressure situations that can lead to misting, poor nozzle performance, or system damage and premature wear.

EZ-FLO® PLUS JAR-TOP SERIES MODEL LIST

Model	Description
50HZ SOLENOIDS	
EZP-02-54	1", Male X Male, BSP without Flow Control
EZP-22-54	1", Male X Male, BSP, with Flow Control
EZP-03-54	1", Female, BSP without Flow Control
EZP-23-54	1", Female, BSP, with Flow Control
LESS SOLENOID	
EZP-02-64	1", Male X Male, BSP, without Flow Control Less Solenoid
EZP-03-64	1", Female, BSP, without Flow Control Less Solenoid
EZP-22-64	1", Male X Male, BSP, with Flow Control, Less Solenoid
DC-LATCHING SOLENOIDS	
EZP-02-94	1", Male X Male, BSP, DCLS-P, without Flow Control
EZP-22-94	1", Male X Male, BSP, DCLS-P, with Flow Control
EZP-23-94	1", Female, BSP, DCLS-P, with Flow Control
EZP-03-94	1", Female, BSP, DCLS-P, without Flow Control

Specifying Information—EZ-Flo® Plus Valve

EZP X-X-X-X				
Model	Flow Control	Body Style	Solenoid	Size
EZP	X	X	X	XX
EZP—EZ-Flo® Plus Valve BSP	0—Without 2—With	2—1" Male x Male BSP 3—1" Female BSP	5—50Hz Solenoid 6—Less Solenoid 9—DC-Latching Solenoid (DCLS-P)	4—1"
Example: A 1" EZ-Flo Plus Valve Female with flow control would be specified as: EZP-23-54				

TPV SERIES VALVES



The search for a full-featured, yet economically priced, residential and commercial valve is over thanks to Toro's 1" valve offering—the TPV Series. These full-featured, rugged, debris-resistant valves range in flow from 0,38 to 151 LPM, making them ideal for everything from drip to high-flow residential and light-commercial applications.

FEATURES & BENEFITS

Double-Beaded, Chloramine- and Ozone-Resistant Diaphragm

Ensures a consistent, leak-proof seal all the way up to 12,0 Bar

Multiple Body Styles

Choose from various styles to meet any installation requirement.

Flow Control

Fine tune the valve's downstream pressure to ensure optimal performance throughout the zone.

Robust Solenoid Design

Ensures reliable opening and closing.

Additional Features

- ✓ Patented Debris Bypass System (DBS™) technology
- ✓ Operates in low-flow and landscape drip applications when a filter is installed upstream
- ✓ Built with either AC or DC Latching Solenoids
- ✓ Manual operation without the use of a controller—internal and external bleed
- ✓ Captured hex/Phillips screws
- ✓ Encapsulated injection-molded solenoid with a captured plunger
- ✓ Removable flow control handle to ensure vandal-resistance
- ✓ Self-aligning bonnet permits fast and easy servicing



Effluent
Options
Available



DC Latching
Solenoid
Option

SPECIFICATIONS

Operational

- Flow Range: 0,38-151,4 LPM
- Operating Pressure: 0,7-12,0 Bar
- Burst pressure safety rating: 68,9 bar
- Solenoid: 24 Vac (50 Hz) Standard (P/N 118-5983)
 - Inrush: 0.4 amps
 - Holding: 0.2 amps

Dimensions

- 130 x 70 x 127mm (H x W x L)

Options Available

- EFF-Kit-50Hz - Effluent Water Solenoid Assembly and Watering Tag
- DCLS-P- Potted DC Latching Solenoid Assembly

Warranty

- Five years

PRODUCT HIGHLIGHT



Flow Control

The precise flow control with ergonomic handle allows fine tuning of the downstream pressure to prevent high pressure situations that can lead to misting, poor nozzle performance, or system damage and premature wear.



Glue Stop

TPV Slip x Slip models include this patented feature that ensures the installer cannot block the downstream port of the valve during installation with primer and cement.

TPV PRESSURE LOSS DATA

Flow Rate (LPM)	0.38	0,94	18,9	37,8	56,8	75,7	113,6	151,4	189,3
Pressure Loss (Bar)	0,14	0,14	0,24	0,27	0,21	0,23	0,48	0,90	1,34

TPV SERIES VALVES MODEL LIST

Model	Description
AC SOLENOIDS	
TPV100BSP	TPV 1" Female x Female, 50Hz/BSP, without Flow Control
TPVF100BSP	TPV 1" Female x Female, 50Hz/BSP, with Flow Control
TPV100MMBSP	TPV 1" Male x Male, 50Hz/BSP, without Flow Control
TPVF100MMBSP	TPV 1" Male x Male, 50Hz/BSP, with Flow Control
DC-LATCHING SOLENOIDS	
TPVF100BSPDC	TPV 1" FxF, Electric Globe, with Flow Control, BSP, DCLS-P
TPV100BSPDC	TPV 1" FxF, Electric Globe, without Flow Control, BSP, DCLS-P
TPVF100MMBSPDC	TPV 1" MxM, Electric Globe, with Flow Control BSP, DCLS-P
TPV100MMBSPDC	TPV 1" MxM, Electric Globe, without Flow Control BSP, DCLS-P

Specifying Information—TPV Series Valves

TPVX100XXXX					
Model	Flow Control	Size	Body Style	Threads, Solenoid	Optional
TPV	X	100	XX	XXX	XX
TPV—TPV Valve	F—With Flow Control	100— 1"	MM—Male X Male	BSP- BSP Threads, 50Hz Solenoid	DC—DCLS-P Latching Solenoid

Example: A 1" TPV Valve Male with flow control would be specified as: **TPV100MMBSP**

264 SERIES VALVES

Heavy duty. Hardworking. The Toro® 264 Series Valves are made to withstand whatever a large residential or light commercial application can dish out

FEATURES & BENEFITS

Heavy-Duty Toro Solenoid

Provides dependable operation and long life.

Single-Piece Rubber Diaphragm

For reliable, leak-tight closing.

Tough, Glass-Filled Nylon Bonnet and ABS Body

Durable construction that provides years of reliable operation.



Additional Features

- ✓ Self-cleaning, stainless steel metering pin
- ✓ External manual bleed
- ✓ 45cm lead wires (electric)
- ✓ Low in-rush solenoid
- ✓ Manual flow control adjustable to zero flow
- ✓ Single-piece rubber diaphragm



SPECIFICATIONS

Operational

- Recommended flow range: 0,9-56,7 LPM
- Operating Pressure: 0,7-10,3 Bar
- Solenoid: 24 VAC-50Hz:
 - Inrush: 0.25 amps, 6.00 VA;
 - Holding: 0.19 amps, 4.56 VA
- Burst Pressure safety rating: 51,7 Bar

Options Available

- 89-7855 - Effluent Water Valve Flow Control Knob

Dimensions

- 75 x 100mm (H x W)

Warranty

- Two years

WATER MANAGEMENT HIGHLIGHT



External Bleed

The external bleed allows perfect manual operation of the valve without electrically charging the solenoid. System flushing can also be accomplished using the external bleed with debris and other material being flushed out of the port.

250/260 SERIES MODEL LIST

Model	Description
264-06-03	¾" Male x Male, Electric, without Flow Control

264 SERIES PRESSURE LOSS DATA

Size	Model	LPM Flow							
		2	25	50	75	100	125	150	175
¾"	Electric	<1.0	0.1	0.4	0.7				

Specifying Information—264 Series Valves

264-X6-0X		
Model	Body Style	Size
264	X6	0X
264—264 Valve	MM—Male X Male	3—¾"

P150 SERIES VALVES



1½" and 2" in-line globe/angle valves for light commercial applications. The P-150 Series valves are the "value" work horses of plastic valves.

Additional Features

- ✓ Non-rising, manual flow control handle; adjustable to zero flow
- ✓ Manual internal bleed
- ✓ No external tubing for either electric or pressure regulating models
- ✓ Positive O-ring seal on inlet plug

FEATURES & BENEFITS

Heavy-duty glass-filled nylon (GFN) and stainless-steel construction

Precise pressure control option with compact EZReg® dial-design

Serviceable under pressure - no need to shut down system

Globe/Angle configuration

Rated at 10 Bar with flows from 20 to 568 LPM

Filter-controlled Water

To resist contamination of solenoid port. Filter serviceable from top of valve.

Pressure regulates in electric and manual modes

Serviceable under pressure



DC Latching
Solenoid
Option



Pressure
Regulation

SPECIFICATIONS

Operational

- Flow range: 18,9-567,8 LPM
- Pressure range: 1,4-10,3 Bar
- Solenoid: 50Hz (24 VAC)
 - Inrush volt-amp: 50Hz (24 VAC) - 7,2 VA
 - Inrush current: .3 amps
- Holding volt-amps: 50Hz (24 VAC) - 4,8 VA
- Holding current: .2 amps
- Body styles - Globe/angle valve: 1½" and 2" BSP female threads

Options Available

- EZR-30 - EZReg, 0,3-2,1 Bar Regulator Module
- EZR-100 - EZReg, 0,3-7,0 Bar Regulator Module
- EFF-KIT-50Hz - Effluent Water (Lavender) Solenoid Assembly (24 VAC, 50 Hz) and Warning Tag
- 118-5983 - 24 VAC Solenoid Assembly, 50 Hz, 457mm Leads, Captive Plunger
- DCLS-P - Potted DC Latching Solenoid Assembly

Dimensions

- 1½": 184mm x 92mm (H x W)
- 2": 241mm x 156mm (H x W)

Warranty

- Five years

PRODUCT HIGHLIGHT



Pressure Regulator

The EZReg® module can regulate with flows of only 19 l/min (0,3 Bar) with a 25mm (1") valve and it only requires 0,7 Bar differential to operate. The pressure regulator can be easily and quickly installed—even under pressure, with no danger of water geysers.

P-150 SERIES PLASTIC VALVE MODEL LIST

Model	Description
EU-P150-23-56	Electric, Globe/Angle, 1½" BSP Plastic Valve, 50 Hz Solenoid
EU-P150-23-58	Electric, Globe/Angle, 2" BSP Plastic Valve, 50 Hz Solenoid
EU-P150-23-96	Electric, Globe/Angle, 1½" BSP Plastic Valve, DCLS-P Solenoid
EU-P150-23-98	Electric, Globe/Angle, 2" BSP Plastic Valve, DCLS-P Solenoid

Note: all w/o Nozzle

P-150 SERIES FRICTION LOSS DATA—LPM FLOW

Size	Configuration	80	100	120	140	160	180	200	250	300	350	400	450	500	550	600
1.5"	Globe Angle	0,22	0,21	0,21	0,17	0,18	0,20	0,31	0,46							
		0,21	0,21	0,22	0,15	0,13	0,13	0,19	0,26							
2"	Globe Angle					0,22	0,22	0,20	0,19	0,26	0,34	0,42	0,42	0,52	0,62	0,74
						0,18	0,17	0,14	0,13	0,16	0,24	0,24	0,26	0,32	0,37	0,43

Flow rates are recommended not to exceed 0,35 Bar loss. Values shown in Bar. Note: For optimum performance when designing a system, be sure to calculate total friction loss to ensure sufficient downstream pressure. For optimum regulation performance, size regulating valves toward the higher flow ranges.

Specifying Information—TPV Series Valves

P150-23-X-X			
Model	Configuration	Solenoid	Size
P150	23	X	X
P150—P-150 Series Plastic Valve	23—BSP, Electric	5—50 Hz Solenoid 9—DCLS-P	6—1½" 8—2"
Example: A 50 mm (2") P-150 Series Plastic Valve with BSP threads and 50 Hz solenoid, would be specified as: P150-23-58			

252 SERIES VALVES



Toro® 252 Series valves are built tough and ready to withstand the harshest conditions in any commercial application. With several configurations to choose from, 252 Series valves are available in electric or hydraulic, 1", 1.5" and 2" globe/angle models with flow control. Each valve diaphragm is a single piece and made with fabric-reinforced rubber for long-term tear and stretch tolerance. All models are female inlet/outlet BSP and their durable plastic construction makes them a cost effective option for commercial applications.

Additional Features

- ✓ 60cm lead solenoid wires on 1½" and 2" models, 45cm lead wires 1" models
- ✓ Self-cleaning, stainless steel metering pin (electric)
- ✓ Tough, glass-filled bonnet
- ✓ Single-piece diaphragm

FEATURES & BENEFITS

Heavy-Duty Toro Solenoid

Provides dependable operation and long life.

Fabric-Reinforced Rubber Diaphragm

Provides long-term resistance to tears and stretching.

Flow Control Handle

Adjusts the flow of each zone on a system.

Robust ABS Body Material and Durable Glass-Filled Cap

Ensures the valve can withstand high pressures and flows without compromise.



Effluent
Options
Available

SPECIFICATIONS

Operational

- Recommended Flow Range:
 - 1": 18,9-75,7 LPM (5-20 GPM)
 - 1½": 94,6-264,9 LPM (25-70 GPM)
 - 2": 227,1-340,6 LPM (60-90 GPM)
- Operating Pressure: 1,3-10,3 Bar
 - Solenoid: 24 VAC, 50Hz
 - Inrush: 0.30 amps, 7.20 VA
 - Holding: 0.20 amps, 4.80 VA
- Burst pressure safety rating: 51,7 Bar

Dimensions

- 1": 171 x 114mm (H x W)
- 1½": 197 x 152mm (H x W)
- 2": 241 x 178mm (H x W)

Options Available

- 89-7855 - Effluent Water Indicator Flow Control Knob

Warranty

- Two years

PRODUCT HIGHLIGHT



External Bleed

The external bleed allows manual operation of the valve without electrically charging the solenoid. System flushing can also be accomplished using the external bleed with debris and other material being flushed out of the port.



Combination Globe and Angle Valve

The all-in-one globe and angle configuration allows flexibility in design and installation. Angle installations allow for less pressure loss across the piping system, while globe configurations are standard in many irrigation systems.

252 SERIES FRICTION LOSS DATA

Size	Type	Config.	LPM Flow													
			25	50	75	100	125	150	175	200	250	300	400	500	600	700
1½"	Hydraulic	Globe				0,07	0,09	0,14	0,18	0,23	0,34	0,44	0,78	1,06		
		Angle				0,07	0,08	0,10	0,10	0,13	0,25	0,34	0,56	0,93		
2"	Hydraulic	Globe									0,14	0,17	0,27	0,43	0,61	0,79
		Angle									0,07	0,13	0,23	0,30	0,37	0,52
1"	Electric	Globe	0,2	0,30	0,34	0,42	0,53	0,65								
		Angle	0,2	0,26	0,31	0,32	0,40	0,51								
1½"	Electric	Globe				0,10	0,11	0,14	0,18	0,23	0,32	0,47	0,84	1,20		
		Angle				0,09	0,08	0,10	0,12	0,16	0,21	0,33	0,52	0,70		
2"	Electric	Globe									0,14	0,17	0,28	0,45	0,61	0,79
		Angle									0,07	0,13	0,23	0,30	0,37	0,52

Note: For optimum performance when designing a system, be sure to calculate total friction loss to ensure sufficient downstream pressure. For optimum regulation performance, size regulating valves toward the higher flow ranges. Flow rates are recommended not to exceed 0,3 Bar loss. = Debris-resistant models

252 SERIES MODEL LIST

Model	Description
FEMALE NPT GLOBE/ANGLE WITH FLOW CONTROL	
252-26-56	1 ½"
252-26-58	2"
252-21-56	1 ½" Normally Open
252-21-58	2" Normally Open

Specifying Information — 252 Series Valves

252-XX-5X			
Model	Activation Type	Thread Type	Size
252	XX		X
252—252 Series Valve	21—Normally Open Hydraulic 26—1½" or 2" Electric	5 - BSP	6—1½" 8—2"
Example: A 1 ½" electric 252 Series Valve, would be specified as: 252-26-56			

Note: DC Latching Solenoid not available.

P-220 SERIES VALVES

For proven reliability in the field, the Toro® P-220 Series valves deliver. Constructed of heavy-duty, glass-filled nylon material, these valves are ready to consistently withstand pressures up to 15,1 Bar.

Additional Features

- ✓ No external tubing for either pressure-regulating model
- ✓ Self-aligning bonnet to ensure correct installation
- ✓ Self-cleaning, stainless steel metering rod
- ✓ Low-flow capability down to 18,9 LPM with EZReg®
- ✓ EPDM diaphragm and seat seal

FEATURES & BENEFITS

Durable Glass-Filled Nylon Construction

Ensures the P-220 can operate at pressures up to 15,1 Bar.

Precise Pressure Control Option

Compact EZReg® dial-design technology can be factory or field installed and does not require the removal of the solenoid.

Standard Schrader Valve at Outlet

Simple verification of downstream pressure.

Optional Spike Guard™ Solenoid

Reduces wire size requirements, allows twice as many valves to run simultaneously on a transformer, and lowers power costs with a lightning rating exceeding 20,000 volts.

Filter Screen On 2" and 3" Models

Allows for upstream filtration of water to ensure no clogging occurs inside the valve.

Flow Control Handle

Adjusts the flow of each zone on a system.



Effluent
Options
Available



Pressure
Regulation



DC Latching
Solenoid
Option

SPECIFICATIONS

Operational

- Flow Range:
 - 1": 18,9-132,5 LPM
 - 1½": 113,6-416,4 LPM
 - 2": 302,8-681,4 LPM
 - 3": 567,8-1135,6 LPM
- Operating Pressure
 - 1" & 1½" Models: 0,7-15,0 Bar
 - 2" & 3" Models: 1,3-15,0 Bar
- Pressure Regulating:
 - Outlet (EZR-30): 0,3-2,0 Bar ± 3
 - Outlet (EZR-100): 0,3-7,0 Bar ± 3
 - Minimum flow requirement of 0,3 Bar

- Minimum Pressure Differential (between inlet and outlet) for Pressure Regulation: 0,7 Bar
- Body Styles:
 - Globe/Angle – 1", 1½", 2" & 3" female threads
- 118-5983 Solenoid: 24 Vac(50Hz)
 - Inrush: 50 Hz, 0.34 amps
 - Holding: 50 Hz, 0.2 amps

Options Available

- EZR-30 - EZReg®, 0,3-2,1 Bar Regulator Module
- EZR-100 - EZReg®, 0,3-7,0 Bar Regulator Module
- EFF-KIT-50HZ - Effluent Water Solenoid Assembly, 24 Vac, 50 Hz; and Warning Tag
- DCLS-P - Potted DC Latching Solenoid Assembly
- 118-5983 - 24 VAC Solenoid Assembly, 50 Hz, 457mm Leads, Captive Plunger

Dimensions

- 1": 171 x 92mm (H x W)
- 1½": 184 x 92mm (H x W)
- 2": 241 x 156mm (H x W)
- 3": 273 x 156mm (H x W)

Warranty

- Five years

PRODUCT HIGHLIGHT



Pressure Regulator

The EZReg® module can regulate flows as low as 0,3 Bar with a 1" valve and only requires 0,7 Bar differential to operate. The pressure regulator can be easily and quickly installed—even under pressure—with no danger of water geysers.

P-220 SERIES MODEL LIST

Model	Description
WITH AC SOLENOID	
P220-23-54	Electric, In-Line 1" BSP Plastic Valve, 50 Hz Solenoid
P220-23-56	Electric, In-Line 1½" BSP Plastic Valve, 50 Hz Solenoid
P220-23-58	Electric, In-Line 2" BSP Plastic Valve, 50 Hz Solenoid
P220-23-50	Electric, Angle 3" BSP Plastic Valve, 50 Hz Solenoid
WITH D.C. LATCHING SOLENOID	
P220-23-94	Electric, In-Line 1" BSP Plastic, with DCLS-P latching solenoid pre-installed
P220-23-96	Electric, In-Line 1½" BSP Plastic, with DCLS-P latching solenoid pre-installed
P220-23-98	Electric, In-Line 2" BSP Plastic, with DCLS-P latching solenoid pre-installed
P220-23-90	Electric, Angle 3" BSP Plastic, with DCLS-P latching solenoid pre-installed

P-220 SERIES PRESSURE LOSS DATA

Size	Config.	LPM Flow																						
		40	60	80	100	120	140	160	180	200	250	300	350	400	450	500	550	600	700	800	900	1000	1100	
1"	Globe	0,29	0,25	0,25	0,26	0,32	0,43	0,55	0,69	0,82														
	Angle	0,29	0,35	0,21	0,20	0,21	0,29	0,38	0,49	0,61														
1½"	Globe					0,12	0,14	0,18	0,23	0,28	0,43	0,62	0,85	1,11										
	Angle					0,09	0,10	0,13	0,17	0,22	0,34	0,48	0,65	0,85										
2"	Globe											0,14	0,20	0,25	0,32	0,40	0,48	0,54						
	Angle											0,08	0,12	0,15	0,19	0,24	0,29	0,32						
3"	Globe																	0,18	0,24	0,32	0,41	0,52	0,65	
	Angle																	0,14	0,19	0,26	0,34	0,43	0,54	

Note: For optimum performance when designing a system, be sure to calculate total Pressure Loss to ensure sufficient downstream pressure. For optimum regulation performance, size regulating valves toward the higher flow ranges. Flow rates are recommended not to exceed 5 psi loss.

Specifying Information—P-220 Series Valves

P220-2X-XX			
Model	Activation Type	Solenoid	Size
P220	2X	X	X
P220—P-220 Series Plastic Valve	23—BSP	5—50Hz Solenoid 9—DC Latching Solenoid	4—1" 6—1½" 8—2" 0—3"

Example: A 1" P-220 Series plastic electric valve with AC Solenoid would be specified as: **P220-23-54**

P-220S SCRUBBER SERIES VALVES

True dirty water irrigation valves, the Toro® P-220S Scrubber Series valves are built to handle chlorine, chloramine, and other chemicals found in reclaimed and non-potable water systems. Constructed of heavy duty glass-filled nylon and EPDM rubber components, the P-220S valves feature Toro's patented ACT™ (Active Cleansing Technology), which helps prevent the build-up of sand, algae, and other organic materials that may inhibit water from metering properly through the valve.

FEATURES & BENEFITS

Multiple Design Configurations

Available in 1", 1 1/2", 2", and 3" inlet/outlet designs, all of which allow the flexibility of globe or angle orientation.

Durable Glass-Filled Nylon Construction

Robustly built to operate at pressures of up to 15,1 Bar

ACT™ (Active Cleansing Technology)

The industry's first active scrubber valve cleans continuously, whereas competing valves only clean upon their opening and closing.

Fabric-reinforced EPDM Diaphragm and EPDM Seat Seal

Designed to work in virtually all water applications.

Rugged Internal Plastic and Stainless Steel Components

The ACT scrubber turbine, nut and metering system are constructed of marine and aerospace-grade plastics and metals that make them resistant to chlorine- and ozone-treated water.

Available with Precise Pressure Regulation

Compact EZReg® dial-design technology ensures precise downstream pressure for optimized sprinkler head performance.

Completely Serviceable and Retrofittable

The ACT scrubber diaphragm assembly can be replaced, and can also be retrofit into previously installed P-220 models.

Additional Features

- ✓ Internal and external bleeds
- ✓ No external tubing for either pressure-regulating model
- ✓ Standard, built-in Schrader-type valve for downstream pressure verification
- ✓ Flow control independent of solenoid
- ✓ Self-aligning bonnet to ensure correct installation
- ✓ Self-cleaning stainless steel metering rod



Effluent
Options
Available



Pressure
Regulation



DC Latching
Solenoid
Option

SPECIFICATIONS

Operational

- Flow Range:
 - 1": 19-151 LPM
 - 1½": 114-416 LPM
 - 2": 302,8-681,3 LPM
 - 3": 567,8-1135,6 LPM
- Operating Pressure
 - 1" & 1½" Models: 0,7-15,1 Bar
 - 2" & 3" Models: 1,4-15,1 Bar
- Pressure Regulating:
 - Outlet (EZR-30): 0,3-2,1 Bar ±0,2
 - Outlet (EZR-100): 0,3-7,0 Bar ± 0,2
 - Minimum flow requirement of 18,9 LPM

- Minimum Pressure Differential (between inlet and outlet) for Pressure Regulation: 0,7 Bar
- Body Styles:
 - Globe/Angle with female threads
- 118-5983 Solenoid: 24 Vac (50 Hz) Standard
 - Inrush: 50 Hz: 0.4 amps
 - Holding: 50 Hz: 0.2 amps

Options Available

- EZR-30 - EZReg®, 0,3-2,1 Bar Regulator Module
- EZR-100 - EZReg®, 0,3-7,0 Bar Regulator Module
- EFF-KIT-50HZ - Effluent Water Solenoid Assembly, 24 Vac, 50 Hz; and Warning Tag
- DCLS-P - Potted DC Latching Solenoid Assembly
- 118-5983 - 24 VAC Solenoid Assembly, 50 Hz, 457mm Leads, Captive Plunger
- SGS -12 - Spike Guard™ Solenoid: 50/60 Hz (24 VAC)

Dimensions

- 1": 171 x 92mm (H x W)
- 1½": 184 x 92mm (H x W)
- 2": 241 x 156mm (H x W)
- 3": 273 x 156mm (H x W)

Warranty

- Five years

PRODUCT HIGHLIGHT



ACT™ Turbine

Filter Surface

The P-220S Scrubber Series Valves Feature Toro's Patented ACT™ (Active Cleansing Technology) system. The ACT system's durable turbine is in constant rotation, which in turn keeps the metering and filtration area free of dirt and algae build-up. The turbine is constructed of materials resistant to chlorine, chloramines, and ozone, thereby keeping the valve operating at peak performance.

P-220S SCRUBBER SERIES MODEL LIST

Model	Description
P220S-23-54	1" BSP with ACT™ System
P220S-23-56	1½" BSP with ACT™ System
P220S-23-58	2" BSP with ACT™ System
P220S-23-50	3" BSP with ACT™ System
P220S-23-94	1" BSP with ACT™ System, DC Latching Solenoid
P220S-23-96	1½" BSP with ACT™ System, DC Latching Solenoid
P220S-23-98	2" BSP with ACT™ System, DC Latching Solenoid
P220S-23-90	3" BSP with ACT™ System, DC Latching Solenoid
P220S-KIT-04	1" Scrubber diaphragm assembly kit
P220S-KIT-06	1½" Scrubber diaphragm assembly kit
P220S-KIT-08	2" Scrubber diaphragm assembly kit
P220S-KIT-00	3" Scrubber diaphragm assembly kit

P-220S SCRUBBER VALVES

Size	Config.	LPM Flow																					
		40	60	80	100	120	140	160	180	200	250	300	350	400	450	500	550	600	700	800	900	1000	1100
1"	Globe	0,32	0,33	0,21	0,42	0,74																	
	Angle	0,29	0,32	0,18	0,38	0,65																	
1½"	Globe			0,08	0,12	0,19	0,29	0,44	0,60	0,77	0,97	1,19	1,41										
	Angle			0,07	0,11	0,18	0,26	0,36	0,48	0,64	0,81	0,99	1,20										
2"	Globe									0,27	0,30	0,30	0,45	0,54	0,64	0,69	0,84						
	Angle									0,19	0,25	0,39	0,39	0,44	0,51	0,62	0,68						
3"	Globe																0,18	0,23	0,35	0,41	0,46	0,53	0,76
	Angle																0,14	0,18	0,32	0,30	0,38	0,48	0,67

Note: For optimum performance when designing a system, be sure to calculate total friction loss to ensure sufficient downstream pressure. For optimum regulation performance, size regulating valves toward the higher flow ranges.

Specifying Information—P-220S Scrubber Series Valves

P220S-2X-XX			
Model	Activation Type	Solenoid	Size
P220S	2X	X	X
P220S—P-220S Scrubber Series Plastic Valve	3-BSP, Electric	5—50Hz Solenoid 9—DC Latching Solenoid	4—1" 6—1½" 8—2" 0—3"

Example: A 2" P-220S Series plastic electric DC, would be specified as: **P220S-23-98**

220 BRASS SERIES VALVES

Heavy-duty brass construction for superior performance under the harshest conditions. Toro® 220 Brass Series valves are rugged and reliable, and offer dependable performance in the toughest situations and settings.

FEATURES & BENEFITS

Leading Lighting Protection (Spike Guard™)

A lightning rating that exceeds 20,000 volts – nearly three times the protection of competing products.

Dirty Water Ready

A stainless steel 120-mesh filter enables dependable valve operation in dirty and reclaimed water applications.

Spike Guard™ Solenoid

Reduces wire size requirements and allows twice as many valves to run simultaneously on a transformer, all while lowering power consumption and related costs.

EZReg® Pressure Regulator compatible

Available in two fully-adjustable models, Toro EZReg Pressure Regulators allow the consistent regulation of pressure within a zone, ensuring optimal operation of all downstream sprinklers. EZReg Pressure Regulators thread directly to the valve bonnet – no special adaptor required and no need to remove the solenoid. The desired pressure can be set fast and with a high level of accuracy thanks to an easy-to-read turn dial design.

Additional Features

- ✓ Commercial-grade 316 Stainless Steel stem for maximum corrosion resistance
- ✓ Manual Flow Control; adjustable to full shut-off
- ✓ Robust, double-beaded, fabric-reinforced rubber diaphragm
- ✓ Built-in Schrader-type valve is standard on all models for fast downstream pressure verification
- ✓ EZReg® Pressure Regulator can be installed as a service kit without having to drain the main line
- ✓ Pressure regulates in electric or manual modes, and is serviceable under pressure

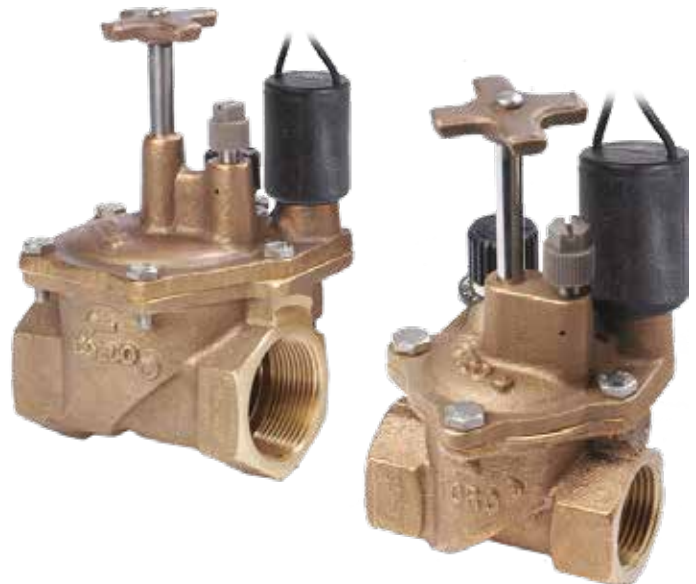

Effluent
Options
Available



Pressure
Regulation



DC Latching
Solenoid
Option



Spike Guard™
Standard

Notes: All come with Effluent Sticker and Label. Compatible with DC Latching Solenoid.

SPECIFICATIONS

Operational

- Flow Range:
 - 1": 118,9-151,4 LPM
 - 1¼": 75,7-378,5 LPM
 - 1½": 75,7-492,1 LPM
 - 2": 113,6-681,3 LPM
 - 2½": 227,1-946,3 LPM
 - 3": 302,8-1324,8 LPM
- Operating Pressure: 1,4-15,1 Bar
- Pressure Regulating:
 - Outlet (EZR-30): 0,3-2,1 Bar ± 0,2
 - Outlet (EZR-100): 0,3-7,0 Bar ± 0,2
 - Minimum flow requirement of 18,9 LPM

- Minimum Pressure Differential (between inlet and outlet) for Pressure Regulation:
 - 1", 1¼", and 1½" models: 0,7 Bar
 - 2", 2½", and 3" models: 1,4 Bar
- Burst Pressure Safety Rating: 51,7 Bar
- Body Styles:
 - Globe orientation – 1", 1¼", 1½", and 2" models, female threads
 - Angle orientation – 2½" and 3" models, female threads

Options Available

- EZReg, 0,3-2,1 Bar regulator module (EZR-30)
- EZReg, 0,3-7,0 Bar regulator module (EZR-100)
- EFF-KIT-50HZ, Effluent Water Solenoid Assembly, 24 Vac, 50 Hz; and Warning Tag
- DCLS-P, Potted DC Latching Solenoid
- 18-5983, 24 VAC Solenoid Assembly, 60 Hz, 450mm Leads, Captive Plunger

Dimensions

- 1": 133 x 127mm H x W
- 1¼": 165 x 152mm H x W
- 1½": 165 x 152mm H x W
- 2": 191 x 178mm H x W
- 2½": 223 x 216mm H x W
- 3": 223 x 216mm H x W

Warranty

- Five years

PRODUCT HIGHLIGHT



Dirty Water Resistance

The 120 mesh stainless steel filter screen is positioned on the supply side of the water stream. It is constantly flushed by the flow, enabling the use of very dirty water without clogging. Stainless steel construction of both the filter screen and the valve solenoid seat ensures long component life in all types of water and pressures.

220 BRASS SERIES VALVES MODEL LIST

Model	Description
50HZ SOLENOID	
220-23-54	Electric, In-Line 1" BSP Brass Valve, 50 Hz Solenoid
220-23-56	Electric, In-Line 1½" BSP Brass Valve, 50 Hz Solenoid
220-23-58	Electric, In-Line 2" BSP Brass Valve, 50 Hz Solenoid
220-23-50	Electric, Angle 3" BSP Brass Valve, 50 Hz Solenoid
LESS SOLENOID	
220-23-64	Electric, In-Line 1" BSP Brass Valve, Less Solenoid
220-23-66	Electric, In-Line 1½" BSP Brass Valve, Less Solenoid
220-23-68	Electric, In-Line 2½" BSP Brass Valve, Less Solenoid
220-23-60	Electric, Angle 3" BSP Brass Valve, Less Solenoid

220 BRASS SERIES VALVES PRESSURE LOSS DATA

Model	Type	LPM Flow																					
		25	50	75	100	125	150	200	250	300	350	400	450	500	600	700	800	900	1000	1200	1400		
1"	Electric	1,75	2,00	2,20	3,10	5,05	7,80																
1¼"	Electric				1,85	2,50	2,70	3,50	4,10	5,60													
1½"	Electric				2,15	2,45	2,80	3,05	3,80	5,00	6,55												
2"	Electric					3,05	3,20	2,90	2,95	3,25	3,40	4,50	6,55	10,10	13,45	14,85							
2½"	Electric								2,00	2,20	2,30	2,40	2,50	3,00	4,00	4,50	5,50						
3"	Electric										2,20	2,40	2,50	3,00	4,00	4,50	5,50	6,50	7,00	7,50			

Notes: For optimum performance when designing a system, calculate total friction loss to ensure sufficient downstream pressure. For optimum regulation performance, size regulating valves toward the higher flow ranges. Flow rates are recommended not to exceed 0,3 Bar loss.

Specifying Information – 220 Brass Series Valves

220-2X-X-X			
Model	Type	Solenoid	Thread Size
220	2X	X	X
220-220 Series Brass Valve	3 - BSP, Electric	5 - 50HZ Solenoid 6 - Less Solenoid	4–1" 5–1¼" 6–1½" 8–2" 9–2½" 0–3"

Example: A 1" BSP, electric 220 Series Brass Valve with 50 Hz Solenoid, would be specified as: **220-23-54**

Note: 1", 1½" and 2"—globe configuration. 2½" and 3"—angle configuration.

QUICK COUPLER SERIES

Whether for hand watering the hot spots, fertilizer wash in, or washing down equipment, Toro® Quick Coupler Valves and Keys are designed for everyday use in environments that require quick remote access to the mainline water supply.

FEATURES & BENEFITS

Stainless Steel And Brass Construction

Quick Couplers are also available with metal or vinyl covers in locking or non-locking options.

Multiple Models To Choose From

There are a variety of one-piece and two-piece models in 3/4" and 1" sizes, including ACME thread key connections.

Eliminate Tangled Hoses

The 360-degree hose swivel provides movement without hose tangling.

QUICK COUPLER SERIES PRESSURE LOSS DATA

Model Number	LPM Flow										
	35	50	75	100	125	150	175	225	275	325	375
075-SLSC	0,1	0,2	0,4	0,6							
100-2SLLC			0,1	0,2	0,3	0,5					

Note: For optimum sprinkler performance when designing a system, be sure to calculate total friction loss to ensure sufficient downstream pressure. Values listed in bar. Flow rates are recommended not to exceed 0,3 bar loss.



3/4" QUICK COUPLING KEYS AND ACCESSORIES MODEL LIST	
Model	Description
075-SLSC	One-piece, 3/4" Single Lug, Quick Coupler w/Standard Metal Cover
075-SLK	3/4" Single Lug Key, with 1/2" Top Pipe Thread Outlet
075-75MHS	3/4" NPT x 3/4" MHT Hose Swivel

1" QUICK COUPLING VALVES AND ACCESSORIES MODEL LIST	
Model	Description
100-SLSC	One-piece, 1" Single Lug, Quick Coupler w/Metal Cover
100-SLVC	One-piece, 1" Single Lug, Quick Coupler w/Vinyl Cover
100-SLVLC	One-piece, 1" Single Lug, Quick Coupler w/Vinyl Locking Cover
100-2SLVC	Two-piece, 1" Single Lug, Quick Coupler w/Vinyl Cover
100-ATLVC	One-piece, 1" Quick Coupler w/Acme Thread and Lavender Locking Vinyl Cover
100-2SLLVC	Two-piece, 1" Single Lug Quick Coupler w/Lavender Vinyl Locking Cover
100-AK	1" Acme Thread, 1" Top Pipe Thread Outlet
100-SLK	Single Lug Key, 1" Top Pipe Thread Outlet w/Internal 3/4" NPT Threads
075-MHS	1" NPT x 3/4" MHT Hose Swivel
100-MHS	1" NPT x 1" MHT Hose Swivel
LK	Key for Locking Cap

Specifying Information—Quick Couplers

XXX-XXX-XXX		
Size	Configuration	Cover
XXX	XXX	XXX
075—3/4" 100—1"	SL—One-piece, Single Lug 2SL—Two-piece, Single Lug AT—ACME Thread	SC—Standard Cover VC—Vinyl Cover LVC—Effluent Vinyl Cover VLC—Vinyl Locking Cover
Example: A 1" one-piece, single lug Quick Coupler with a vinyl locking cover, would be specified as: 100-SLVC		

VALVE ACCESSORIES

SOLENOIDS



DCLS-P

- Potted DC Latching Solenoid for Toro valves
- Compatible with EZ-Flo Plus, TPV, P-200, P-220S Scrubber and 220 Brass Series valves.



118-5983

- 24 Vac Solenoid assembly for EZ-Flo Plus, TPV, P-150, P-220, P-220S Scrubber, and 220 Brass Series valves.
- Captive hex plunger
- 18" leads



SGS-12

- 24 Vac Spike Guard Solenoid assembly for EZ-Flo Plus, TPV, P-150, P-220, P-220S Scrubber, and 220 Brass Series valves.
- 20,000 volts lightning rating
- Inrush 0.2 amps/ Holding 0.1 amps



LWS

- 19 Vac Low Wattage Solenoid assembly for EZ-Flo Plus, TPV, P-150, P-220, P-220S Scrubber, and 220 Brass Series valves.
- Inrush 0.2 amps/ Holding 0.1 amps

EFFLUENT WATER INDICATORS



EFF-KIT-50HZ

- Lavender-colored 118-5983 Solenoid assembly for EZ-Flo Plus, TPV, P-220, P-220S Scrubber, and 220 Brass Series valves.
- Lavender-colored Effluent warning tag



RWSG-Kit

- Effluent tag and Solenoid sticker

UNIVERSAL VALVE BOXES*



EU-TUCS

Toro Universal valve box small circular

EU-TUCM

Toro Universal valve box medium circular

EU-TURS

Toro Universal valve box standard rectangular

EU-TURJ

Toro Universal valve box jumbo rectangular

EZREG® PRESSURE/INSTALLATION REGULATOR & EHC ACCESSORIES



EZR-30 and EZR-100

- Pressure regulator module for use with P-150, P-220, P-220S Scrubber and 220 Brass Series Valves
- EZR-30: 0,3–2,0Bar
- EZR-100: 0,3–7,0Bar



995-51

- Pressure gauge kit



995-49

- 0-200 psi pressure gauge
- Hermetically sealed shock resistant face



850-00

- Valve cover



995-14

- Supply screen fitting



995-02

- Flushing adaptor

*For details see pag. 153

CONTROLLERS

From standard to advanced irrigation control, Toro® irrigation controllers meet the needs of the most demanding users. Innovative sensing and wireless communication capabilities give users even more control over water savings and maintaining healthy landscapes.





CONTROLLERS

Pages 93-116

TEMPUS™DC	95-96
Electronic Tap Timer	97-98
DDC™WP	99-100
TEMPUS™	101-102
TEMPUS™PRO	103-104
LAWN MASTER II	105-106
DDC™	107-108
EVOLUTION® Series	109-110
TMC-424E Series	111-112
Custom Command™ Series	113-114
TDC Series Two-Wire System	115-116

TEMPUS™ DC SERIES **NEW!**

Thanks to the advanced features, the new Tempus™DC is the ideal controller to manage irrigation in areas without electricity. Bluetooth connectivity is integrated to allow intuitive programming thanks to the new Toro App mobile. Tempus™DC is available in two versions: with and without LCD screen.



FEATURES & BENEFITS

100% Waterproof

IP68, the TempusDC can be installed directly in the valve box.

UV resistant plastics

Battery operated (4xAAA battery for LCD model; 9V battery for NO LCD model)

1 Season autonomy

Input for rain sensor

Thanks this option you will save water for an intelligent and eco-friendly use.

Large display for LCD model: 4,5x6,0 cm

The practical display is the largest on the market for this product line: this will allow you to program the controller more easily

Water Budget from 0% to 200%

The watering times can be easily set up for the whole year and then adjusted by percentage from 0% to 200% with increments of 10%: a real intelligent programming thanks to the easy adjustment of the seasonal irrigation.

Additional Features

- ✓ 1, 2, 4, 6 stations
- ✓ 4 independent programs
- ✓ 3 start times for program
- ✓ Permanent programs retention in memory in case of battery replacement
- ✓ Internal clock maintained in case of power failure
- ✓ Installation on top of the valve thanks to a dedicated bracket (in option)



Rain Sensor
Compatible

SPECIFICATIONS

Technical

- Watering time from 1 minute to 8 hours (1 min increase)
- Flexible irrigation programming:
 - Daily
 - Weekly
 - Irrigation on even and odd days
 - Irrigation at 1 to 31 day intervals
- Stacking Program
- Automatic, semi-automatic and manual start
- Permanent memory
- Rain delay programmable from 1 up to 15 days or "permanent»

Electrical

- Rated IP68, 100% Waterproof
- Battery operated (4x1.5V battery for LCD model; 9V battery for NO LCD model)
- Operating temperature: -10°C + 50°C
- Output 9 VDC latching
- Maximum distance of 300 m between controller and DCL latching solenoid (cable section 0,75mm²)

Dimensiones

- TEMPUS™ DC without LCD: 12cm x 11,5cm x 5 cm (W x H x D)
- TEMPUS™ DC with LCD: 10,5 cm x 15,5cm x 5 cm (W x H x D)
- Weight:
 - TEMPUS™ DC without LCD: 250 gr.
 - TEMPUS™ DC with LCD: 260 gr.

Warranty

- 2 Years

PRODUCT HIGHLIGHTS

EASY TO PROGRAM

Bluetooth connectivity is integrated to allow intuitive programming from your device thanks to the new TempusDC App.



TEMPUS™ DC SERIES MODEL LIST

Model	Description
TEMP-1-DC	Tempus DC, battery-powered controller, 1 station with bluetooth, no LCD
TEMP-2-DC	Tempus DC, battery-powered controller, 2 stations with bluetooth, no LCD
TEMP-4-DC	Tempus DC, battery-powered controller, 4 stations with bluetooth, no LCD
TEMP-6-DC	Tempus DC, battery-powered controller, 4 stations with bluetooth, no LCD
TEMP-1-DC-L	Tempus DC, battery-powered controller, 1 station with bluetooth and LCD
TEMP-2-DC-L	Tempus DC, battery-powered controller, 2 stations with bluetooth and LCD
TEMP-4-DC-L	Tempus DC, battery-powered controller, 4 stations with bluetooth and LCD
TEMP-6-DC-L	Tempus DC, battery-powered controller, 4 stations with bluetooth and LCD

Specifying Information—TEMPUS DC

TEMP-X-DC-X			
Description	Stations	Version	Screen
TEMP	X	DC	X
TEMP—Tempus Controller	1—1 Station 2—2 Stations 4—4 Stations 6—6 Stations	DC - 9 VDC latching solenoid	L - LCD Display

Example: Tempus Controller 4 stations with LCD display would be specified: **TEMP-4-DC-L**

ELECTRONIC TAP TIMER

A durable, battery-operated electronic tap timer from Toro. With multiple programs and an efficient, built-in solenoid and diaphragm valve, the Toro tap timer is a dependable and convenient solution for hose-end irrigation control.



FEATURES & BENEFITS

Battery-operated

One 9-volt alkaline battery (not included) provides sufficient power to last an irrigation season

Weather-resistant controller, tap connected controller

¾" or 1" connection with built-in valve

2-minute program back-up

When batteries are temporarily removed for replacement

Additional Features

- ✓ Large, easy to read LCD
- ✓ 7-key touchpad operation
- ✓ Convenient 24-hour clock
- ✓ 7 day "Select-A-Day" calendar
- ✓ Up to 8 start times per day
- ✓ Automatic or manual functions
- ✓ Manual count-down mode (from 8 hours to 5 minutes)
- ✓ External ON/OFF button
- ✓ Summer/Winter key used for "daylight savings" adjustment
- ✓ 15 different preset watering day combinations
- ✓ Bushing contains removable, cleanable filter
- ✓ 2 Minute program back up when batteries are temporarily removed
- ✓ Battery life indicator

SPECIFICATIONS

Technical

- Three scheduling choices by program:
 - Seven-day calendar
 - 1 to 7-day interval
 - Odd/even with 365-day calendar and 31st day exclusion
- Station run times from one minute to four hours in one-minute increments
- Seasonal adjust by month from 0-200% in 10% increments
- Manual operation by station or program
- Self-diagnostic circuit breaker skips shorted stations
- Up to five-year program retention with on-board coin battery saves time of day and all programming features
- Vandal proof lock out feature

Electrical

- ¾" or 1" tap connection in single model
- One 9V Alkaline battery required (not included)
- Typical battery life of one season (6 months) based on normal use
- Recommended flow rate at 2,0 Bar: 15,1 LPM
- Maximum flow rate: 40 LPM
- Operating pressure: 1,4-7,0 Bar
- Maximum operating pressure: 9,9 Bar
- Recommended operating temperature: 5°C to 38°C
- RoHS and CE compliant times per program

Warranty

- One year

PRODUCT HIGHLIGHTS

EASY CONNECTION

Connects directly to either a ¾" or 1" outdoor water tap or filter

SIMPLE PROGRAMMING

15 different preset watering day combinations simplify initial programming and setup.



Specifying Information — ELECTRONIC TAP TIMER

Description	Voltage
TTT	9V
TTT- Toro Tap Timer	9V—9 Volt (Battery not included)

DDC™ WP SERIES

Looking for a rugged waterproof controller ideal for remote or isolated installations? Toro's DDCWP Series controller provides all that and more. The DDCWP is battery-operated using two 9V batteries, and controls up to 8 potted DC latching solenoids.



FEATURES & BENEFITS

Fully Waterproof and Submersible

Submersible up to 1,9 m per IP-68 standards, the controller can be direct-mounted in a valve box.

Operates DC Latching Solenoids

Controller is compatible with most manufacturers' DC latching solenoids.

Exclusive "Digital Dial" Technology

Simple programming functions.

Unique Power Feature

Verifies sufficient voltage level for turning stations off before turning any stations on.

Monthly Watering Schedule

Monthly preset option – ideal for automatic runtime adjustments.

Easy to Use Lock-out Feature

Press the "ON/OFF" button for three seconds to lock out the controller and protect it against vandalism. Press again to return to normal operation.

PRODUCT HIGHLIGHTS



1 = The first month, January

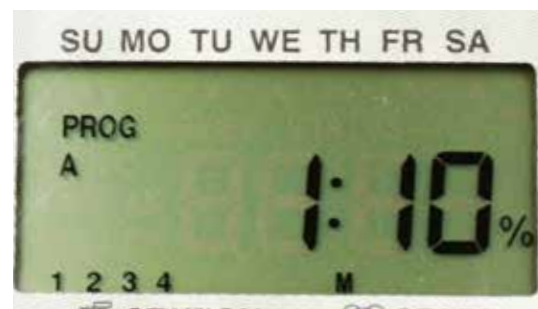

10 = 100%. 140% would be designated as 14.

MONTHLY % ADJUST

DDCWP adjusts annual irrigation run time during initial controller set up. Options include from 0-200% and January to December scheduling. With easy adjusting for seasonal watering, water savings is enhanced for all-around intelligent programming.



Wired Rain Sensor
Compatible

SPECIFICATIONS

Technical

- Three independent programs and three start times per program
- Three scheduling choices by program:
 - Seven-day calendar
 - 1 to 7-day interval
 - Odd/even with 365-day calendar and 31st day exclusion
- Station run times from one minute to four hours in one-minute increments
- Seasonal adjust by month from 0-200% in 10% increments
- Manual operation by station or program
- Self-diagnostic circuit breaker skips shorted stations
- Up to five-year program retention with on-board coin battery saves time of day and all programming features
- Vandal proof lock out feature

Electrical

- Operating temperature: 0° - 60°F
- Operates using two 9V alkaline batteries (not supplied)
- Operates one latching solenoid per station and one latching solenoid-equipped master valve
- Controller is compatible with all Toro valves accepting latching solenoids (model DCLS-P or equivalent) and competitive valve models/latching solenoids
- Accepts Toro TRS Wired RainSensor™, Wired Rain/Freeze and other normally-closed sensors
- Low-battery indicator visible on LCD screen

Dimensions

- 146mm x 127mm x 50mm (W x H x D)
- Weight: 660,5 gr. without 9V battery

Warranty

- Three years

PRODUCT HIGHLIGHTS



BATTERY CAP

Easy installation of two 9V batteries with the simple screw ON/OFF lid. The battery cap provides a dependable leak-proof seal allowing submersion up to 1,9m per IP-68.



LATCHING SOLENOID

EZ-Flo® Plus and P-220 valves shown with the DCLS-P latching solenoid which provide cost and labor savings.

WIRE RUN LENGTHS FOR DDCWP

With battery voltage at 9 Vdc, maximum recommended wire runs for an 8-station DDCWP are:

Multi-strand Wire	Distance (Ft.)
1,0mm ² (18 AWG)	60m (197)
1,5mm ² (16 AWG)	93m (305)
2,5mm ² (14 AWG)	150m (493)
4,0mm ² (12 AWG)	250m (820)

DDCWP SERIES MODEL LIST

Model	Description
DDCWP-2-9V	2-station
DDCWP-4-9V	4-station
DDCWP-6-9V	6-station
DDCWP-8-9V	8-station

Specifying Information — DDCWP

DDCWP-X-9V		
Description	Stations	Voltage
DDCWP	X	9V
DDCWP—Digital Dial Waterproof Controller	2—2 Stations 6—6 Stations 4—4 Stations 8—8 Stations	9V—9 Volt

Example: An 8 station DDCWP controller would be specified as: **DDCWP-8-9V**

TEMPUS™ SERIES **NEW!**

TEMPUS™: the ultimate controller of the Toro range. With this product you will be the real master of your garden: Discover all the new features of a product that has no equal in the market.

FEATURES & BENEFITS

Arm chair programming

This feature gives you the opportunity to remove the controller from the wall and to program it from any room in the house.

Modularity

Tempus™ is the only controller in the market with a modular option: this means that only 1 control unit can be purchased and used for the various versions (Basic/ Pro) and for different irrigation systems (indoor and outdoor).

Design

Thanks to its colors and its look&feel modern and elegant, Tempus is also a furnishing accessory for your home.

Local Wi-Fi Module (optional)

The optional Wi-Fi module enables the controller to be remotely monitored and accessed anywhere in your home.

So download the new Toro App, create your account and connect to your device!



Wired Rain Sensor
Compatible

PRODUCT HIGHLIGHTS

SIMPLY AND INTUITIVE PROGRAMMING THANKS TO THE DIAL WITH 4 OPTIONS



HELP BUTTON

This very useful button will help you in programming by explaining what to do: the instruction manual will become superfluous

LOCAL WI-FI MODULE



SPECIFICATIONS

Technical

- 4, 6, 8 Stations
- 2 independent programs
- 3 start times per program
- Watering time: from 1 min to 8 hours (1 min increase)
- Flexible irrigation programming:
 - Daily
 - Irrigation on even and odd days
 - Irrigation at 1 to 30 day intervals
- Rain delay programmable up to 31 days or “permanent”
- Water Budget from 0% to 200%
- Stacking Program
- Automatic, semi-automatic and manual start
- Test program for all the stations
- Permanent Memory
- Help button (programming only)

- The “Super Cap” option provides back up power for maintaining the current time and date in the event of a power cut for more than 24 hours (without needing batteries)
- Multilingual display (Italian, English, French, Spanish, German)
- CE Certified

Electrical

- Input power:
 - 220 VAC, 50Hz
- Output power
 - Max per station 24 VAC (0,25 A)
 - Max tot (including Master Valve): 24 VAC (0,625 A)
- Operating Temperature: from -10° to 60°C

Option

- Local Wi-Fi Ready

Dimensions

- 186 mm x 140 mm x 67mm (W x H x D)
- Weight: 0,6 kg

Warranty

- Two years

TEMPUS™ ASSEMBLED SERIES MODEL LIST	
Model	Description
TEMP-4	4 stations, external transformer 220 VAC
TEMP-6	6 stations, external transformer 220 VAC
TEMP-8	8 stations, external transformer 220 VAC
TEMP-4-EXT	4 stations, internal transformer 220 VAC
TEMP-6-EXT	6 stations, internal transformer 220 VAC
TEMP-8-EXT	8 stations, internal transformer 220 VAC

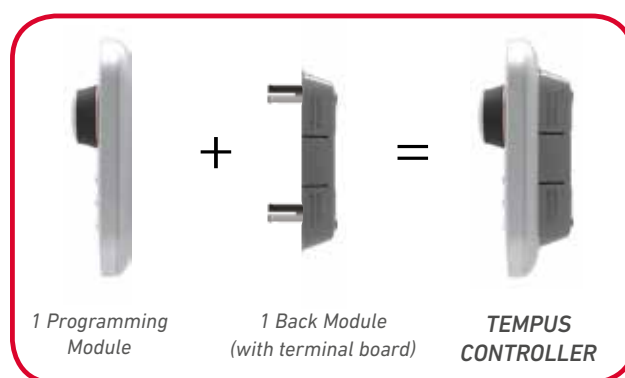

ACCESSORIES	
Model	Description
TEMP-WF	Local Wi-Fi module for Tempus

TEMPUS™ MODULAR SERIES MODEL LIST	
Model	Description
TEMP-MOD	Programming Module
TEMP-B-4	Back Module 4 stations, external transf. 220 VAC
TEMP-B-6	Back Module 6 stations, external transf. 220 VAC
TEMP-B-8	Back Module 8 stations, external transf. 220 VAC
TEMP-B-4-EXT	Back Module 4 stations, internal transf. 220 VAC
TEMP-B-6-EXT	Back Module 6 stations, internal transf. 220 VAC
TEMP-B-8-EXT	Back Module 8 stations, internal transf. 220 VAC

Specifying Information — TEMPUS Assembled Series

TEMP-X-XXX		
Model	Station	Cabinet Type
TEMP	X	XXX
TEMP - Assembled Tempus Controller	4 - 4 Stations 6 - 6 Stations 8 - 8 Stations	(blank) — Indoor EXT—Outdoor

Specifying Information — TEMPUS Modular Series*

TEMP-XXX		+	TEMP-X-X-XXX			
Model	Module		Model	Module	Station	Cabinet Type
TEMP	XXX		TEMP	X	X	XXX
TEMP - Tempus Controller	MOD - Programming Module		TEMP - Tempus Controller	B - Back Module + terminal board	4 - 4 Stations 6 - 6 Stations 8 - 8 Stations	(blank) — Indoor EXT—Outdoor

*Example: Tempus Controller 6 stations with external transformer would be specified: **TEMP-MOD + TEMP-B-6**

TEMPUS™ PRO SERIES **NEW!**

Tempus™PRO is a step forward in the Tempus range: with this controller is possible to have the full control of your irrigation at any time and wherever you are. Easy to install and to program, with several large features, Tempus™PRO is the ideal controller for any residential application.



FEATURES & BENEFITS

Modular

From 4 to 16 stations, base of 4 stations with expanding module of 4 stations each (indoor and outdoor)

IOT Wi-Fi Module (optional)

The optional Wi-Fi module enables the controller to be remotely monitored and accessed anywhere within range of your home wireless network device, and can be remotely controlled with a smartphone

Hydraulic test capability

Electrical test capability

Loop program

One of the 4 programs can be set as "Continuous cycle program"

Multiple choice

The sensors can be managed in 5 different modes (Off, Start, Stop, Skip, Pause)

Additional Features

- ✓ Arm chair programming
- ✓ Possibility to work in m:h or s:m (up to 8 min)
- ✓ Programmable rain delay between stations (from 1 sec to 8 min)
- ✓ Pulse sensor input



Rain
Sensor
Compatible



Flow
Sensor
Compatible

SPECIFICATIONS

Technical

- 4 independent programs
- 6 start times per program
- Flexible irrigation programming:
 - Daily
 - Weekly
 - Irrigation on even and odd days
 - Irrigation at 1 to 30 day intervals
- Rain delay programmable up to 31 days or "permanent"
- Water Budget from 0% to 200%
- Stacking Program
- Automatic, semi-automatic and manual start
- Test program for all the stations
- Permanent Memory
- Rain sensor activation through switch
- Sensors may be managed in 5 different modes (Off, start, stop, skip, hold)
- Pulse sensor may be active when no valve is working

- The "Super Cap" option provides back up power for maintaining the current time and date in the event of a power cut for more than 24 hours (without needing batteries)
- Electronical or mechanical program retention possibility
- Help button (programming only)
- Multilingual display (Italian, English, French, Spanish, German)
- CE Certified

Electrical

- Input power: 220 VAC, 50Hz
- Output power:
 - Max per station 24 VAC (0,25 A)
 - Max tot (including Master Valve): 24 VAC (0,625 A)
- Operating Temperature: from -10° to 60°C

Option

- IOT Wi-Fi Ready
- 4 stations expanding module

Dimensions

- 186 mm x 140 mm x 67mm (W x H x D)
- Weight: 1,5 kg

Warranty

- Two years

PRODUCT HIGHLIGHTS

EXPANDING MODULE



Expanding modules of 4 stations

OPTIONAL IOT WI-FI MODULE



Thanks to the Toro App, you will always be connected to your irrigation system at any time and wherever you are!



TEMPUS™ PRO ASSEMBLED SERIES MODEL LIST	
Model	Description
TEMP-P	4-stations, Indoor, 220 VAC
TEMP-P-EXT	4-stations, Outdoor, 220 VAC
TEMP-P-SM	Station expanding module 4 stations

ACCESSORIES	
Model	Description
TEMP-P-WF	IOT Wi-Fi module for Tempus Pro

TEMPUS™ PRO MODULAR SERIES MODEL LIST	
Model	Description
TEMP-MOD	Programming module
TEMP-P-B	4-stations, Indoor, back part+transformer, 220 VAC
TEMP-P-B-EXT	4-stations, Outdoor, back part+transformer, 220 VAC

Specifying Information — TEMPUS™ PRO Modular Series

TEMP-XXX		+	TEMP-P-X-X-XXX			+	TEMP-P-SM	
Model	Module		Model	Module	Cabinet Type		Model	Parts
TEMP	XXX		TEMP-P	X	XXX		TEMP-P	SM
TEMP - Tempus Controller	MOD - Programming Module		TEMP-P - Tempus Pro Controller 4 stations	B - Back Module + transformer	(blank) — Indoor AC Model EXT—Outdoor		TEMP-P - Tempus Pro Controller	SM - Station expanding module 4 stations

Example: a 8 station Tempus controller in an outdoor cabinet would be specified as: **TEMP-MOD + TEMP-P-B-EXT + TEMP-P-SM**

LAWN MASTER® II - LANDSCAPE TIMER

Saving water and saving time has never been easier. Lawn Master® II efficiently works with new or existing systems and drip irrigation to Automate watering – saving water and promoting a healthy landscape. And Lawn Master® II is simple to install and program.



FEATURES & BENEFITS

Automate traditional and drip irrigation systems

3 Programs with up to 3 start times per program

Efficiently works with new or existing systems

Simple to install and program

4 Zone capacity with port for optional rain sensor

Money and water saving features

- 3 Programs—For flexible watering according to plant type or zone type, including drip irrigation.
- Seasonal Adjust— Automatically adjusts run times for all zones for increased watering in hotter months and less watering during cooler months without reprogramming the timer.
- 3 Start Times— Enables customized programming according to plant types and water needs.
- Rain Sensor Port — Easily add a Toro RainSensor™ for water conservation without troublesome splicing.
- 365 Day Calendar— Conveniently enables programming based on municipal water restrictions.

Additional Features

- ✓ 3 independent watering programs and up to 3 start times per program, perfect for traditional and drip irrigation.
- ✓ Pump Start Relay and Rain Sensor Ports for easy connection with no wire splicing.
- ✓ 365 Day Calendar—Water on specific days of the week, odd or even days, or day interval, with day exclusion to meet water restrictions.
- ✓ Seasonal Adjust—Adjust run times as weather or seasons change.
- ✓ Three modes of operation—Automatic, Manual Station, and Manual Program.
- ✓ Battery back-up stores programming (9 volt battery required).
- ✓ A.M./P.M. clock allows user to set length of watering from 1 minute to 6 hours.



Wired Rain Sensor
Compatible

SPECIFICATIONS

Technical

- Indoor/Outdoor
- Zone Capacity: 4-6 zones
- Start Times: 3 per program (9 total)
- Run Times: Up to 360 Minutes
- Day Schedule Options:
 - Specific days
 - Day interval
 - Odd/Even
 - Day exclusion
- Modes of operation: Automatic, Manual Zone and Manual Program
- Seasonal Adjust: Increases or decreases watering time by 10-200% as seasons or Weather change

Electrical

- Electrical input power:
 - 220 VAC, 50 Hz
 - CE compliant
 - Battery Backup: 9-volt battery required
- Max Output to Valves: 350mA per Station
- Transformer Input: 220 VAC, 50 Hz
- Transformer Output: 24 VAC at 0,75 A

Dimensions

- 112.7 cm x 16.5 cm x 2.5 cm (W x H x D)

Warranty

- Three years

PRODUCT HIGHLIGHTS

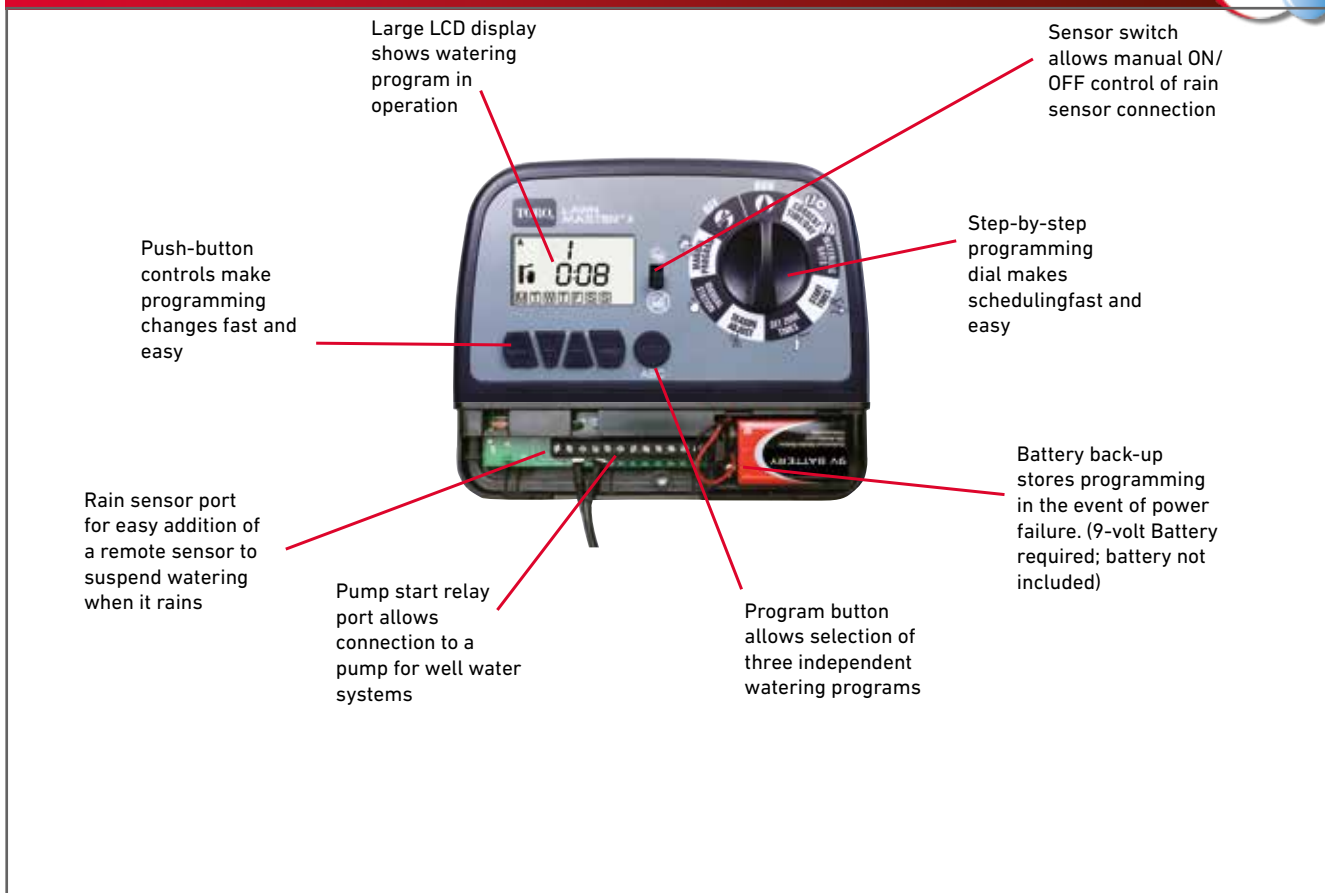

LAWN MASTER® II SERIES MODEL LIST

Model	Description
LMII-4-220	Lawn Master® II Landscape Timer, 4 Zone
LMII-6-220	Lawn Master® II Landscape Timer, 6 Zone

Specifying Information — LAWN MASTER II

LMII-X	
Description	Stations
LMII	X
LMII - Lawn Master® II Landscape InDoor Timer	4-4 Stations 6-6 Stations

Example: An 4 station LMII controller would be specified as: **LMII-4**

DDC™ SERIES

The DDC features an exclusive, patented virtual dial interface that guides a user through simple programming functions. Although compact in size, several large features are packed into the DDC – making it extremely affordable for any residential application.



FEATURES & BENEFITS

Toro exclusive “Digital Dial” Technology

Simulates the simplicity of a mechanical dial

3 independent programs

Easily identified within “digital dial” interface

Water Budget: 0 to 200% in 10% increments

Monthly preset option — ideal for system start-up or shutdown in advance

Self-diagnostic circuit breaker

Identifies irrigation faults

Multi-lingual Display

User selectable multi-language overlays

Additional Features

- ✓ 4, 6 and 8 Station
- ✓ 3 Start Times per Program
- ✓ 365 Day Calendar
- ✓ 1 to 240 minute run times with delay between stations
- ✓ Multiple watering days options:
 - 7 day calendar
 - 14 day interval
 - Odd/Even day watering, with 31st day exclusion
- ✓ Arm-Chair programming with 9-volt battery power source
- ✓ Key locking outdoor cabinet provides vandal resistance



SPECIFICATIONS

Technical

- Large LCD display
- Manual programs start for programs stored in controller memory
- Built-in Rain delay with sensor terminal hookups
- Programmable Master Valve
- Convenient program review feature
- Program retention with on board coin battery
- Default program if loss of power occurs
- Quick reference card for programming assistance
- CE, EMC, C-Tick, UL and cUL approved
- Accepts Toro TWRS or TWRFS wireless rain/freeze sensor
- Program review feature
- Self diagnostic circuit breaker

Electrical

- Input power: 220 VAC, 50 Hz (Plug-in transformer, CE Mark)
 - 0.50 amps (60 W) maximum
- Station Output Power: 24 VAC
 - 0.25 amps (6 VA) per station maximum
 - 0.25 amps (6 VA) pump start/master valve
 - 0.50 amps (12 VA) total load

Dimensions

- Indoor:
 - 127mm x 146mm x 40mm (H x W x D)
 - Weight without 9-volt battery: 280 grams
 - 500mA class 2 transformer
- Outdoor:
 - 20mm x 178mm x 89mm (H x W x D)
 - Weight without 9-volt battery: 1,14 Kg

Warranty

- Two years

WATER MANAGEMENT HIGHLIGHT

MONTHLY SEASON ADJUST

Irrigation run times can be set and then pre-adjusted for entire year from 0-200% in 10% increments by month. With easy adjusting for seasonal watering, water savings is enhanced for all around intelligent programming.



DDC SERIES 220 VAC MODEL LIST	
Model	Description
INDOOR DIGITAL DIAL CONTROLLERS	
DDC-4-220	4-Station, Indoor, 220 VAC Plug-In Transformer, Exclusive Digital Dial
DDC-6-220	6-Station, Indoor, 220 VAC Plug-In Transformer, Exclusive Digital Dial
DDC-8-220	8-Station, Indoor, 220 VAC Plug-In Transformer, Exclusive Digital Dial
OUTDOOR DIGITAL DIAL CONTROLLERS	
DDC-4-220-OD	4-Station, Outdoor, 220 VAC, Exclusive Digital Dial
DDC-6-220-OD	6-Station, Outdoor, 220 VAC, Exclusive Digital Dial
DDC-8-220-OD	8-Station, Outdoor, 220 VAC, Exclusive Digital Dial

Specifying Information — DDC™ Series

DDC-X-XXX-XX			
Description	Stations	Power Supply	Cabinet
LMII	X	XXX	XX
DDC - Digital Dial Controller	4—4 Stations 6—6 Stations 8—8 Stations	220 — 220 VAC	(blank) — Indoor AC Model OD — Outdoor AC Model*

Example: An 8- station indoor DDC controller with 220 Va.c. plug-in transformer, would be specified as: **DDC-8-220**

EVOLUTION® SERIES

The Toro® EVOLUTION® series controller has changed the way we think about irrigation control. It combines a modern and intuitive design with wide-ranging functionality, making it perfect for everyday residential use, yet able to meet the needs of more complex landscapes.

FEATURES & BENEFITS

Water-Saving Wireless Accessories

The unique Smart Connect® receiver plugs into the back of the front panel, enabling it to wirelessly communicate directly with a number of add-on devices—including a weather sensor, handheld remote, multiple soil sensors, and up to two wireless relays.

Powerful Features

The EVOLUTION controller comes standard with features ready to meet the wide-ranging needs of your clients, such as three independent watering schedules, and a stand-alone Auxiliary schedule, modular expansion from 4 to 16 zones, and the capability to power up to four standard solenoids.

Additional Features

- ✓ Up to six schedules:
 - Three irrigation schedules, four start times per schedule
 - One wired auxiliary schedule, plus two optional wireless auxiliary schedules
- ✓ Three scheduling choices:
 - Seven-day calendar
 - 1 to 30-day interval with up to seven day exclusions
 - Odd/even days with up to seven day exclusions
- ✓ Monthly season adjust by schedule
- ✓ Schedule stacking, with automatic split cycle when watering adjustments are greater than 100%
- ✓ Grow-in schedule settable up to 90 days, automatically reverts to regular irrigation schedule
- ✓ Station runtimes from one minute to twelve hours
- ✓ Allows 30, 60, or 90 second manual runtimes for things such as winterization/blowouts
- ✓ Programmable well-recovery/station-delay from 10 seconds to 30 minutes
- ✓ Pump start delay from 10 seconds to 30 minutes
- ✓ Master valve ON/OFF by zone



When equipped with a Wireless ET Weather Sensor (EVO-WS)



PSS
Compatible



Rain
Sensor
Compatible



Flow
Sensor
Compatible



SPECIFICATIONS

Electrical

- Electrical input power:
 - 120 Vac
 - 30 VA maximum
 - UL, CUL Listed
- Station output power:
 - 24 Vac
 - 0.75 amps per station maximum
 - 0.75 amps pump/master valve
 - 1.0 amps total load
- Surge Protection:
 - 6.0 KV common mode; 1.0 KV normal mode
- Operation of two solenoids per station

Dimensions

- 11 1/4" W x 7 3/4" H x 4 1/4" D
- Weight: 4.5 lbs.

Warranty

- Five years

PRODUCT HIGHLIGHTS



Smart Connect® Add-On Devices

Simply plugging the Smart Connect® into the EVOLUTION® controller allows it to communicate wirelessly with a number of add-on devices, providing a great opportunity to upgrade with a number of different water-saving and time-saving options.



Handheld Remote

Backlit display makes maintenance checks a snap, day or night, allowing you to run sprinklers or schedules from up to 1000 feet away.



Toro® Smart Connect® Plug-In Receiver

Installs easily on the backside of the EVOLUTION® controller's front panel. No wires, no externally mounted receiver. One Smart Connect® Receiver is all that is required to communicate to all Add-On Devices.



Wireless ET Weather Sensor

Combines real-time temperature and solar measurements with historical ET data for your location to automatically calculate and adjust the irrigation schedule.



Precision™ Soil Sensor

Up to three soil sensors can be used (one per schedule) to monitor the moisture level in the soil and prevent over- and underwatering. With up to a 500 feet wireless range, there's no digging required to install.

EVOLUTION SERIES MODEL LIST

Model	Description
EVO-4ID-EU	4-station Indoor Controller
EVO-4OD-EU	4-station Outdoor Controller
ADD-ONS AND ACCESSORIES	
EMOD-4	4-station Expansion Module
EMOD-12	12-station Expansion Module
EVO-SC-EU	Smart Connect® Plug-In Receiver
EVO-WS-EU	Wireless ET Weather Sensor
EVO-HH-EU	Wireless Handheld Maintenance Remote
PSS-KIT-EU	Precision Soil Sensor Kit, Europe - CE Approved

Specifying Information - EVOLUTION® Series

EVO-XX-XX-SC			
Description	Cabinet Type	Module	Connector Options
EVO	XX	XX	SC
EVO – EVOLUTION Controller	ID – Indoor OD – Outdoor	4 – No Additional Modules 8 – One, 4-Station Modules 12 – Two, 4-Station Modules 16 – One, 12-Station Module	SC – Smart Connect®

Example: A 16-station EVOLUTION controller in an indoor cabinet with Smart Connect would be specified as: **EVO-ID-16-SC**

TMC-424E SERIES

The Toro® TMC-424E Series takes modularity to a whole new level. Toro's advanced modular technology combines sophisticated features with simple operation to provide a customizable controller.

FEATURES & BENEFITS

Station Count Modularity

Station count modularity from 4 to 24 stations using 4- or 8-station modules for flexibility.

Two Levels of Surge Protection

Standard or High Surge modules provide options to meet regional lightning protection needs.

Flow-Sensing

Monitor and react to system leaks or breaks.

Up to 4 Master Valve or Pump Start Connections

Options for connection of up to four Master Valve or Pump Start Relays utilizing TSM-4F or TSM-8F modules.

Run Times In Minutes or Seconds

Ability to set run times for less than a minute provides efficient watering for planter box, misting cycle, nursery, or syringe cycle needs.

Armchair Programming

Removable Timing Mechanism can be powered by 9V battery allowing for easy and comfortable programming.



Additional Features

- ✓ Four programs with 16 total start times
- ✓ Three Scheduling choices:
 - Seven-day calendar
 - 1- to 31-day interval with day exclusion
 - Odd/even days with day exclusion
- ✓ Station run times in minutes or seconds
- ✓ Programmable well recovery/station delay from 1 to 60 seconds or 1 to 60 minutes
- ✓ Pump start/master valve settable by program and station
- ✓ Operate up to three programs simultaneously
- ✓ Rain delay from one to 14 days and water budgeting from 0-200% in 10% increments
- ✓ Hot-swappable station modules
- ✓ Review feature quickly recaps all program information
- ✓ Short detection for faster troubleshooting
- ✓ Valve Test mode for quick system checks
- ✓ Multi-language capability (English, Spanish, French, Italian, German and Portuguese)
- ✓ Program erase
- ✓ 12/24-hour real-time clock
- ✓ Non-volatile memory



SPECIFICATIONS

Electrical

- Input power:
 - 220/240 VAC, 50 Hz
 - 30 VA (internal and external plug-in type transformer)
 - UL, CUL-listed
- Station output power:
 - 24 Vac
 - 0.50 amps per station maximum
 - 0.50 amps pump/master valve
 - 1.20 amps total load
- Surge Protection:
 - Standard – 6.0 KV common mode; 600 V normal mode
 - High Surge – 6.0 KV common mode; 6.0 KV normal mode

Dimensions

- 273mm x 260mm x 117mm W x H x D
- Weight: Indoor – 3,4 kg.; Outdoor – 3,2 kg

Optional Accessories

- TRS – Wired RainSensor
- 53853 – Wired Rain/Freeze Sensor
- TWRS/TWRFS – Wireless RainSensor or Wireless Rain/Freeze Sensor
- TFS-Flow Sensor

Warranty

- Five years



EPA WaterSense® certified when used with Irritrol® Climate Logic®

WATER MANAGEMENT HIGHLIGHT



FLOW-SENSING FOR GREATER WATER SAVINGS

With flow-sensing capability that monitors up to three independent flow sensors, the controller consistently monitors for problems and takes action as needed to isolate breaks or system issues.

UP TO 4 MASTER VALVE/PS CONNECTIONS

One on controller terminal block and 3 flow-sensing modules. Any station can be assigned to any MV. Options for a single station to activate both a controller and flow module MV/PS connection (e.g., MV and Booster Pump activation).

TMC-424E SERIES MODEL LIST

Model	Description
TMC-424E-ID-50H*	Modular, Indoor
TMC-424E-OD-50H*	Modular, Outdoor
* Base models include TSM-4 (4-station Module)	
STATION MODULES - BASE MODEL INCLUDES 4 STATIONS	
TSM-4	4-station Expansion Module
TSM-4H	4-station Expansion Module, High-Surge
TSM-4F	4-station Expansion Module, Flow-Sensing
TSM-8	8-station Expansion Module
TSM-8H	8-station Expansion Module, High-Surge
TSM-8F	8-station Expansion Module, Flow-Sensing

Specifying Information — TMC-424

TMC-424E-XX-XX-XX			
Model	Type	Description	
TMC-424E	XX	XX-XX-XX	
TMC-424E—Toro Controller	ID—Indoor OD—Outdoor	4—4-station, Standard-Surge 4H—4-station, High-Surge 4F—4-station, High-Surge and Flow-Sensing	8—8-station, Standard-Surge 8H—8-station, High-Surge 8F—8-station, High-Surge and Flow-Sensing
Example: A 16-station TMC-424E controller in an indoor cabinet with one flow monitor would be specified as: TMC-424E-ID-8F-8			

* Note: Base model comes with one TSM-4 (4-station) included.

CUSTOM COMMAND™ SERIES

With the highest surge protection in its price range, the Toro® Custom Command offers durability and performance in one rugged commercial-grade controller.

FEATURES & BENEFITS

Versatile Runtimes

Runtimes from one minute to ten hours in one-minute increments meet the needs of standard or drip applications.

Independent Programs

Four fully independent programs and 16 start times that can run concurrently with start time overlap protection within each program.

Metal or Plastic Enclosures

Available in wall-mount metal cabinet with optional metal pedestal, or wall-mount plastic cabinet.

Hand-Held Remote Compatible

Compatible with the Toro TMR-1 Maintenance Remote for ease of use, troubleshooting, and field maintenance operation.

Additional Features

- ✓ Three selectable watering schedules:
 - Seven-day calendar
 - Odd/even days with day exclusion
 - 31-day interval
- ✓ 365-day calendar with automatic compensation for leap year
- ✓ Rain delay from one to seven days
- ✓ Program stacking for simultaneous operation of one to four programs (four program stacking only in 36- and 48-station models)
- ✓ Season % adjust by month
- ✓ Individual station manual start and manual start by program
- ✓ Independent program erase for each program
- ✓ Master valve/pump start operation selectable by program
- ✓ Available in 9-, 12-, 15-, 18-, 24-, 36- and 48-station models



EPA WaterSense® certified when used with Irritrol® Climate Logic®



PSS
Compatible



Rain
Sensor
Compatible



Multiple Enclosure Options
Metal or plastic cabinets and optional metal pedestals meet a variety of installation needs.

SPECIFICATIONS

Electrical

- Input Power
 - 230 VAC, 50 Hz
 - 0.50 amps (24 W) maximum
- Station output power
 - 24 Vac (60 Hz)
 - 0.50 amps (12 VA) per station maximum
 - 0.50 amps (12 VA) pump/master valve
 - 1.25 amps (30 VA) total load
- UL, CUL Listed

Dimensions

- Plastic: 292 x 149 x 219mm (W x H x D)
- Metal (24-stations): 273 x 247 x 146 mm (W x H x D)
- Metal (36- and 48-stations): 273 x 400 x 146 mm (W x H x D)
- Weight
 - Plastic: 3,6 kg
 - Metal (24-station): 6-8 Kg
 - Metal (36- and 48-station): 8,2 Kg

Optional Accessories

- TRS – Wired RainSensor
- 53853 – Wired Rain/Freeze Sensor
- TWRS/TWRFS – Wireless RainSensor or Rain/Freeze Sensor

Warranty

- Five years

PRODUCT HIGHLIGHT



Wired RainSensor or Wireless Rain/Freeze Sensors
Stops irrigation when it rains or when temperature drops below a user-defined point.

High-Surge Protection
With the highest surge protection in its competitive price range, a self-diagnostic circuit breaker and a five-year warranty, this controller withstands the test of time.

Additional Features *(continued)*

- ✓ Non-volatile memory retains programmed information in event of power failure
- ✓ Time and date retention for up to 90 days using 9-volt battery
- ✓ Self-diagnostic circuit breaker that identifies and overrides faulty stations

CUSTOM COMMAND SERIES MODEL LIST

Model	Description
WALL-MOUNT PLASTIC CABINET	
CC-P12-50H	12-station
CC-P15-50H	15-station
CC-P18-50H	18-station
CC-P24-50H	24-station
WALL-MOUNT METAL CABINET	
CC-M24-50H	24-station
CC-M36-50H	36-station
CC-M48-50H	48-station

Specifying Information — Custom Command

CC-XXX-XXX			
Model CC	Cabinet X	Description XX	Power XX
CC—Custom Command	M—Metal P—Plastic	9—9-stations 12—12-stations 15—15-stations 18—18-stations 24—24-stations 36—36-stations 48—48-stations	50H—230 VAC/50Hz

Example: A 12-station Custom Command Controller with an internal transformer and plastic cabinet would be specified as: **CC-P12-50H**

TDC SERIES TWO-WIRE SYSTEM

For an energy efficient, highly cost-effective way to irrigate large commercial installations, you'll want the TDC Series from Toro®. Using a two-wire path to communicate to buried decoders, the TDC system eliminates high costs associated with traditional valve wiring, trenching and trouble-shooting.

FEATURES & BENEFITS

Integrated Surge Decoders

Industry leading surge protections up to 20 KV means less grounding in the field than competitive products.

Advanced Diagnostics

The TDC provides true two-way communication with each decoder in the field, thus providing communication verification to decoders in the field, as well as shorted or open solenoid conditions, making troubleshooting a breeze.

Low-Power Operating Costs

The TDC Decoders operate DC Latching Solenoids which utilize no power when valves are in operation.

Water Budget

Water budget by controller, by program and by station (Season Adjust) 0 to 250% in 1% increments.

Simple, Intuitive Programming

Installation and future servicing are quick and simple thanks to the large LCD display and the industry's most intuitive interface.

Additional Features

- ✓ 20 KV surge protection with proper grounding of 10 Ohms or less at the controller
- ✓ 10 independent irrigation programs
- ✓ Six start times per program
- ✓ Day of the week programming, odd/even, interval (1-31 days)
- ✓ 0-255% adjust by controller, by program, by station
- ✓ Day Exclusion (remove a day from standard program)
- ✓ Programmable master valve and pump start, by station
- ✓ Manual start of each station or entire program
- ✓ Non-volatile memory retains programming
- ✓ Self-diagnostics circuit breaker skips shorted/open stations
- ✓ Two-way confirmation of decoder activation
- ✓ Activate up to 20 solenoids at up to 2.8 miles away
- ✓ Programmable rain delay up to 31 days
- ✓ Water window calculator
- ✓ 10-digit alpha-numeric zone identification
- ✓ Remote-Ready and RainSensor-compatible
- ✓ Upgradeable to Sentinel® Central Control
- ✓ Utilizes DC latching solenoids for valve control



Rain
Sensor
Compatible

SPECIFICATIONS

Electrical

- Input Power: 220/240 VAC (50/Hz)
- Station Output Power: Up to 38 Vac maximum; 3 amps max. output
- Wiring—two wire path:
Jacketed, twisted pair 14 AWG to 4572m
- Wiring—two wire path:
Jacketed, twisted pair 16 AWG to 2576m
- Wiring—decoder to solenoid:
Standard pair 14 AWG to 122m.

Dimensions

- Cabinet:
1356mm x 330mm x 152mm (W x H x D)
- Stainless steel pedestal-mount:
435 x 876 x 219 mm (W x H x D)

Optional Accessories

- DEG-SG-LINE – Decoder, Line Surge Protector
- TRS – Wired RainSensor
- 53853 – Wired Rain/Freeze Sensor
- TWRS/TWRFS – Wireless RainSensor or Wireless Rain/Freeze Sensor

Warranty

- Five years



KEY-LOCKING, FRONT-ENTRY, METAL CABINET

TDC offers a key-locking cabinet in both the outdoor and indoor model controllers. Constructed from heavy-duty powder-coated metal, this is a wall-mount cabinet that provides superior weather and vandalism resistance.

STAINLESS STEEL PEDESTAL OPTION

TDC units may also be ordered preinstalled in a stainless steel pedestal.

Please specify **CDEC-PED-100** or **CDEC-PED-200**.

MODULAR DESIGN

The base model of the TDC offers 100 stations with capability to add another module allowing up to 200-station control. This is ideal for phased projects. Independently fused wire paths (4 per 100 stations = 8 for 200 stations) provide protection to the controller in the event of a short in field wiring.

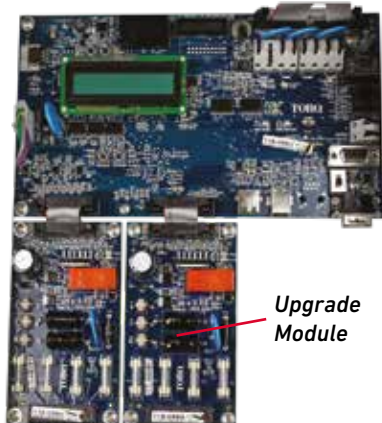

TDC SERIES MODEL LIST

Model	Description
METAL PEDESTAL MOUNT	
CDEC-SA-100	100-station, with remote connection
CDEC-SA-200	200-station, with remote connection
CDEC-PED-100*	100-station, Two-wire controller on stainless steel pedestal
CDEC-PED-200*	200-station, Two-wire controller on stainless steel pedestal
TWO-WIRE STATION DECODERS	
CDEC-ISP-1	1-station with integrated surge protection (Operates up to two solenoids)
CDEC-ISP-2	2-station with integrated surge protection (Operates up to four solenoids)
CDEC-ISP-4	4-station with integrated surge protection (Operates up to eight solenoids)

*To be order via Eicon

Specifying Information—Decoders

Model	Description
CDEC-ISP-1	Single Station Decoder with integrated surge protection
CDEC-ISP-2	Two Station Decoder with integrated surge protection
CDEC-ISP-4	Four Station Decoder with integrated surge protection

Specifying Information—DEC

Model	Description
DEC-SG-LINE	Decoder, line surge protector*

*One per 457 m

Specifying Information—TDC

CDEC-XXX-XXX		
Model	Cabinet	Description
CDEC	XXX	XXX
CDEC—Two-wire Controller with remote hook up	SA—Wall Mount Metal Cabinet PED—Stainless Steel Pedestal	100—100 Stations 200—200 stations

Example: A TDC Controller with 200 stations would be specified as: **CDEC-SA-200**

SENSORS & REMOTES

With today's focus on sustainable landscapes, Toro sensors have proven significant water savings and control for both residential and commercial applications.





SENSORS & REMOTES

Pages 117-132

Precision™ Soil Sensor	119-122
Turf Guard®	123-124
Wireless ET Weather Sensor	125-128
Wireless RainSensor™	129
Wired RainSensor™	130
TFS Flow Sensors	131
EVOLUTION® Smart Connect® Remote	132

Leveraging Toro® sensing technology used on high-end commercial sites and world-class golf courses around the globe, the Toro Precision™ Soil Sensor reduces water waste by continuously measuring moisture levels in the soil and determining when to allow your controller to water, maximizing the efficiency of your irrigation system. Communication between the sensor probe and receiver is completely wireless, so installation is quick and easy with no digging required.



PRECISION™ SOIL SENSOR

FEATURES & BENEFITS

Works with Nearly All Irrigation Controllers

Can be installed on any irrigation controller, including competitive models.

Prevents Overwatering

Continuously measures soil moisture levels and determines when to allow your irrigation controller to water, making sure just the right amount of water is applied.

No Digging Required

Communication between the sensor probe and the receiver is completely wireless, with up to a 152,4 m range (line of sight). Installation doesn't disturb the soil, giving you accurate moisture readings starting as soon as the sensor is put in the ground.

Automatic Calibration

The sensor will automatically detect the soil type and adjust all calculations accordingly.

Freeze Detection

The only soil sensor to offer freeze detection that prevents irrigation when temperatures approach freezing.

Additional Features

- ✓ Sensor receiver hooks up to irrigation controller's sensor port (if available) or is wired into common wire
- ✓ Up to 152,4m Range, line of sight
- ✓ One sensor per receiver
- ✓ Adjustable moisture threshold in 1% increments allows the user to set the desired moisture level
- ✓ Smart Bypass™ overrides the sensor for a user-defined length of time (especially useful during system winterization)
- ✓ If the sensor is tripped while the irrigation controller is in the middle of a watering program, the optional "Cycle Delay" feature ensures all subsequent zones in the irrigation program have a chance to get watered before the sensor halts watering



HOW IT WORKS

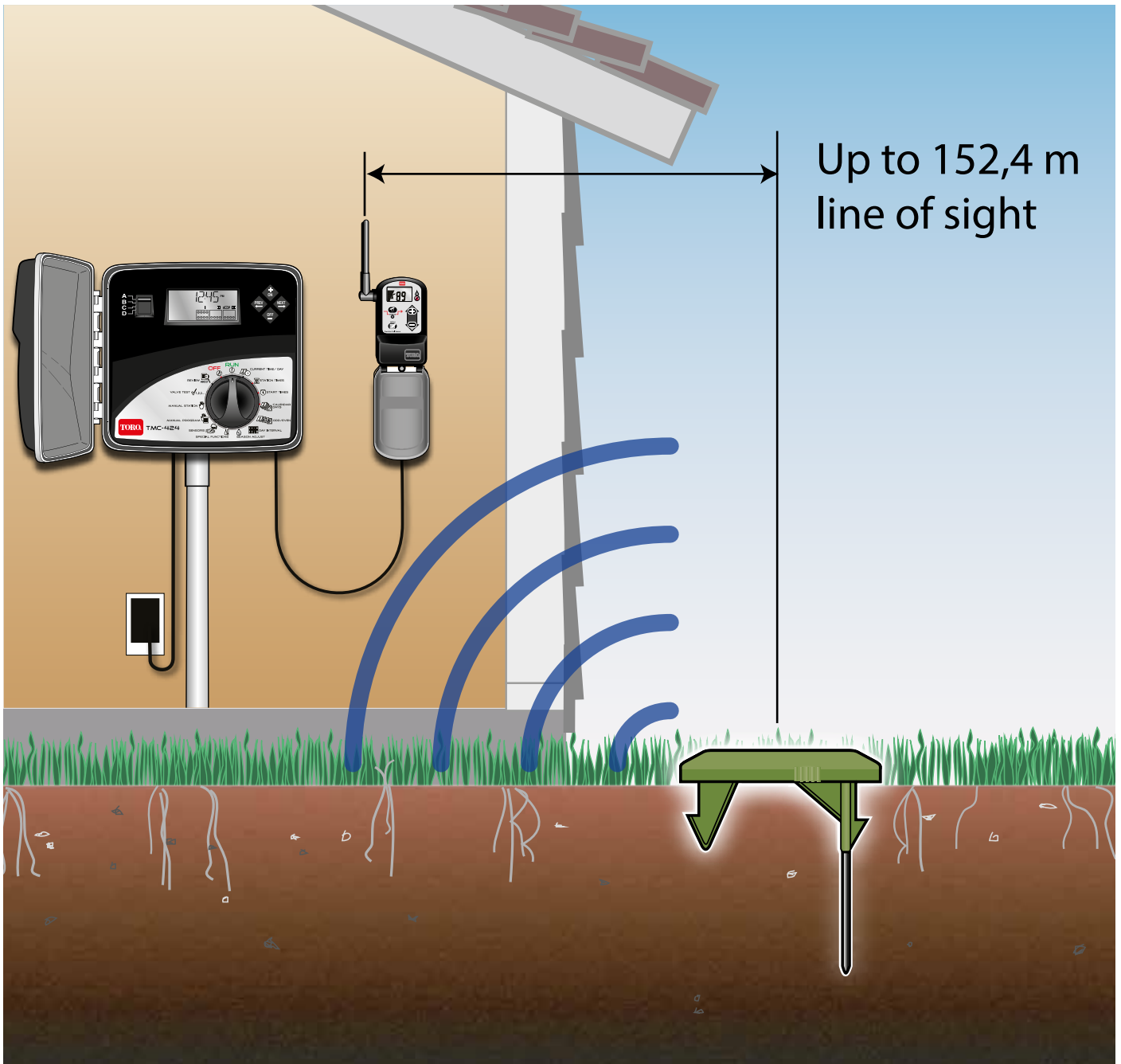

- There are two components to the system - a battery-powered wireless sensor probe and a receiver that wires into any irrigation controller's sensor port.
- Once installed, the sensor calculates field capacity for your soil (or the maximum amount of water the soil can hold after excess water has drained away) and sets that as "100%".
- Any time the moisture level in the soil exceeds field capacity, the irrigation controller is prevented from watering until the moisture level falls below the level set in the receiver (default is 50% of field capacity, adjustable by the user).

SPECIFICATIONS

Electrical

- Receiver input power: 24 Vac
- Probe: Three AA batteries

Temperature

- Operating (Probe): -10°C to 77°C
- Operating (Receiver): -10°C to 60°C
- Storage: -30°C to 65°C

Dimensions

- Probe body: 127mm x 95mm x 19mm
- Probe spikes: 121mm (
- Receiver body: 76mm x 95mm x 38mm

Warranty

- Two years

UNIVERSAL PSS-KIT INSTALLATION

1

Hook up the receiver to your irrigation controller



2

Install the batteries to power up the sensor probe



3

Place the probe in the ground



Additional Features *(continued)*

- ✓ Multi-color LED on the sensor probe indicates radio signal strength
- ✓ Sensor probe's ultra-slim 1,9 cm (3/4") profile allows it to avoid being damaged by mowing equipment
- ✓ Extra long stainless-steel electrodes measure over 10 cm into the soil profile
- ✓ Sensor probe's support stakes hold sensor firmly in place when installed
- ✓ Easily replaceable batteries last up to two years with alkaline batteries (longer with lithium)



Specifying Information—Precision™ Soil Sensor

Model	Description
PSS-KIT-EU	Precision Soil Sensor (Probe + Receiver) - European Version - (868 MHz)

The Toro® Turf Guard Wireless Soil Monitoring system is a revolutionary technology that lets you know what's going on beneath the surface of your turf, so you can make timely, more-informed adjustments.



TURF GUARD® SOIL MONITORING SYSTEM

FEATURES & BENEFITS

Wireless Communication

Turf Guard's advance wireless MESH network technology makes for an easy installation with no trenching required.

Monitor Moisture Levels in the Soil

Reduce water usage and improve playability without risking turf quality. Promote root growth by avoiding over watering and detect dry areas before it impacts the turf's health.

Track Salt Build-up And Schedule Flushing

Take the guesswork out of monitoring and managing salinity levels. Know when and how much water to flush with.

Review Daily Soil Temperatures

Predict peak soil temperatures early in the day to start remediation activities before an emergency. Schedule fungicide applications and pesticides for optimal effectiveness.

Additional Features

- ✓ Comes with free SiteVision™ software for viewing data
- ✓ Advanced MESH routing technology overcomes obstacles
- ✓ Durable sensor housing is resistant to aeration damage
- ✓ Supports up to 500 sensors per system
- ✓ Expected sensor battery life of three years, field replaceable
- ✓ Sensor reading sent every five minutes
- ✓ Measures two distinct depths in the soil profile
- ✓ Automatic network configuration and failure recovery
- ✓ Graphical system overview displays sensor data at-a-glance
- ✓ Plots trends and compares historical and current readings
- ✓ Move quickly from system-wide averages to individual sensor readings

SPECIFICATIONS

Electrical

- Input Power:
 - Repeater: <0.02 amps @ 6 Vdc
 - Base Station: <0.1 amps @ 220 VAC, 50Hz

Temperature

- Operating: 0°C to 60°C
- Storage: -30°C to 82°C

Dimensions

- Body: 50mm x 92mm x 156mm
- Spikes: 44mm x 5mm
- Installation Hole Diameter: 108mm

Communication

- Repeater Range: Up to 1524m line-of-sight
- Buried Sensor Range: Up to 152.4m line-of-sight
- 869,4-869,65 MHz (EU Model)
- Additional licensing not required

Warranty

- Comes with one year of NSN support (extended support plans available)



Specifying Information—Turf Guard

Model	Description
TG-S2-R-EU	Turf Guard Sensor with Replaceable Battery
TG-R-INT-EU	Repeater-Internal Mount
TG-R-EXT-EU	Repeater-External Mount
TG-B-EU	Base Station
TG-PS-EU	Power Supply

The Toro® Wireless ET Weather Sensor makes saving water easy through the automatic management of the irrigation schedule. Combining real-time temperature and sunlight measurements with location-based ET (evapotranspiration) data, the Wireless ET Weather Sensor wirelessly communicates seasonal adjustments to the EVOLUTION® Series controller. The EVOLUTION controller uses the information to automatically adjust the scheduled runtimes, helping to ensure the landscape receives just the right amount of water.



WIRELESS ET WEATHER SENSOR

FEATURES & BENEFITS

On-site Weather in Real-time

Continuously monitors temperature and sunlight to generate schedule adjustments based on what's happening at the site.

Built in Rain/Freeze Sensor

Adjustable freeze sensor and rain gauge automatically suspends irrigation in the event of precipitation and near-freezing temperatures.

Completely Wireless

Installed in minutes and powered by a single 9V battery, the sensor presents ultimate flexibility with a communication range of 300 m*.

Historical Weather Information

The sensor includes a decades' worth of historical weather data for North America that is used by the controller to generate schedule adjustments in the event of communication issues due to a depleted battery.

No Fees

The sensor is self-sufficient and does not require any external data, or associated subscription fees, to operate.

*Line of sight

Additional Features

- ✓ EPA WaterSense certified when used in combination with the Toro EVOLUTION Series controller
- ✓ Sensor data and schedule adjustments viewable on-demand through EVOLUTION Review screens
- ✓ QuickClip™ mounting arm
- ✓ Automatic freeze shutoff feature prevents watering when temperatures approach freezing
- ✓ Low battery indicator and alert in the EVOLUTION controller
- ✓ Dryout days are adjustable between 0-14 days after a rain event
- ✓ One sensor can support multiple controllers within range



EPA WaterSense approved
when equipped with an
EVOLUTION® Series controller



HOW IT WORKS

EVOLUTION Series Controller with Smart Connect receiver



Install sensor where it will receive full sun exposure and unimpeded rainfall

Up to 300 m line of sight

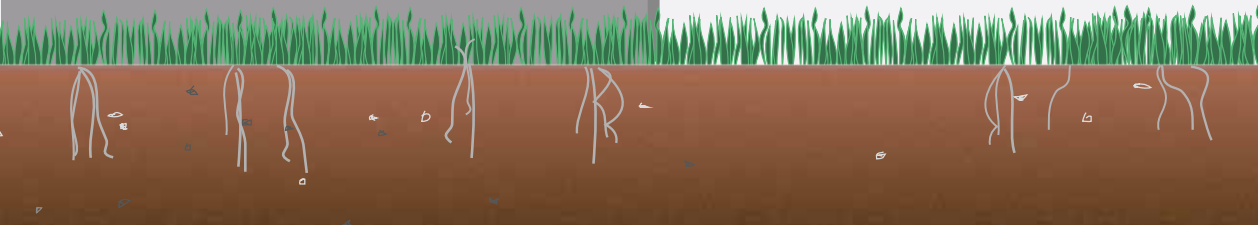

TWO MOUNTING OPTIONS:

QuickClip™ Gutter Bracket

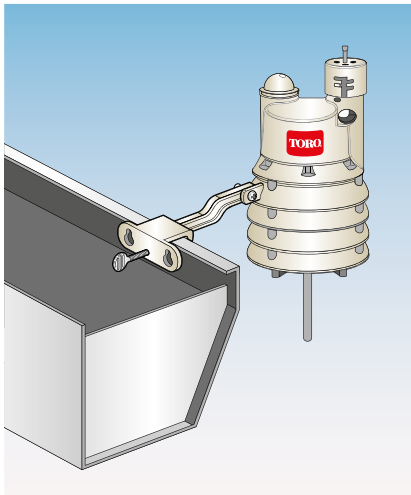

Wall Mount

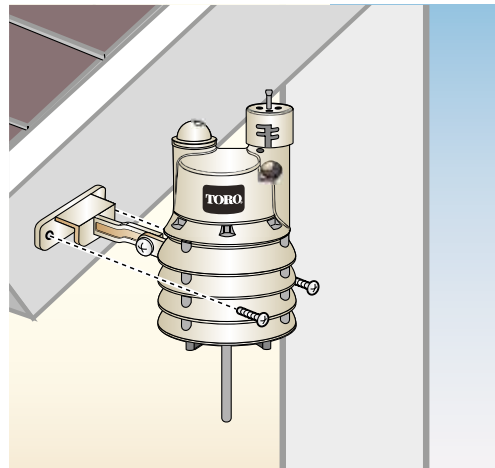

SPECIFICATIONS

Operational

- Sensor wirelessly connects with the EVOLUTION Series controller via the Smart Connect receiver (EVO-SC, sold separately)
- Up to 300 m range, line of sight
- EPA WaterSense certified when used in combination with the Toro EVOLUTION Series controller
- FCC Approved

Electrical

- 9 V Battery

Temperature

- Operating: -25,7°C to 60°C
- Storage: -30° C to 65° C

Dimensions

- 15,2x16,5x6.9 cm (mounting arm extended)

Warranty

- Five years



EVOLUTION® Series controller and Smart Connect® receiver



EPA WaterSense approved
when equipped with an
EVOLUTION® Series controller

Specifying Information—Wireless ET Weather Sensor

Model	Description
EVO-WS-EU	Wireless ET Weather Sensor for use with EVOLUTION Series controller (equipped with Smart Connector™ Europe, 868 mHz)

WIRELESS RAINSENSOR™



No wires. No hassle. Just reliable rain sensing that provides optimum water savings. Toro® innovative wireless technology provides easy to use, advanced features for prompt reaction when it starts to rain.

FEATURES & BENEFITS

Smart Bypass™

Allows for system override at any time and resets automatically.

Rain/Freeze Combination

Features digital programmable accuracy – a first in the industry. The Freeze shutoff can be set from 2° to 7°C in 0,5° increments.



Water Conservation Modes

Selectable water conservation modes delay resumption of irrigation by intelligently extending beyond mechanical reset time and can save you up to 30%* more water.

* Savings vary based on sensor setting, watering schedule and other conditions.

Additional Features

- ✓ Low battery indicator
- ✓ Signal strength indicator/scale
- ✓ Rain delay feature that works intelligently with the rain sensor (unlike most controller-based rain delays)
- ✓ Fail-safe modes in the event of loss of communications or failed sensor
- ✓ Real-time outside temperature displayed on the LCD (TWRS only)
- ✓ Five year easy to replace, standard coin batteries
- ✓ Versatile mounting options: one-piece Quick-Clip™ gutter bracket or 1/2" conduit adapter
- ✓ Can control multiple receivers/controllers with one sensor transmitter



SPECIFICATIONS

Operational

- Operating temperature: -28°C–49°C
- Housing material: Weather and UV resistant engineered polymer
- Transmitting range: up to 152,4 m (line-of-sight) with adjustable antenna
- Sensor: maintenance free hygroscopic disks; adjustable rain sensitivity: 3mm-20mm

Dimensions

- Transmitter: 44mm x 89mm x 44mm (W x H x D)
- Receiver: 51mm x 102mm x 44mm (W x H x D)
- Weight: 0,4 kg product and carton

Electrical

- Transmitter Power: Two replaceable lithium cells (CR2032-3V)
- Receiver Power Source: 22-28 Vac/Vdc, 100mA (from existing timer or optional transformer)
- Relay contacts output: Normally-opened or normally-closed; 3A @ 24 Vac
- FCC, IC, AVA, UL, CUL, CE and C-tick approved

Warranty

- Five years

Specifying Information–Wireless

Model	Description
TWRS-I	Toro Wireless RainSensor, 433,92 MHz
TWRFS-I	Toro Wireless Rain/Freeze Sensor, 433,92 MHz

WIRED RAINSENSOR™



When it rains sometimes all you need is a simple sensor that ensures the job gets done. With multiple set-points for adjustable rain sensitivity and maintenance-free sensing disks, Toro's TRS provides the reliability required.

FEATURES & BENEFITS

Compatible With All Toro And Other Manufacturers' Controllers

Universal Normally Open and Normally Closed operation for compatibility with all controllers that are designed to accept a sensor device.

Maintenance Free Hygroscopic Discs

Industry standard sensing discs with adjustable rain shut-off indexes at 3mm, 6mm, 13mm, and 20mm

7,6 m Of UV-Resistant Cable

Includes 7,6m of white outdoor-rated, UV-resistant cable.



Wired Rain/Freeze Sensor
New Wired Rain/Freeze Sensor automatically suspends irrigation when the temperature drops below 2,8°C saving piping networks and irrigation components.



First LCD In A Wireless Rainsensor
Provides informative system feedback including outside temperature, and transmitter signal strength and battery life.

SPECIFICATIONS

Operational

- Relay contacts output, normally open or normally closed: 3A, 24 Vac
- Operating temperature: -28°C to 49°C
- Low profile design and UV-resistant housing for sensor
- No special tools required for installation

Dimensions

- Transmitter: Transmitter: 44mm x 89mm x 44mm (W x H x D)
- Weight: 0,4 kg product and carton

Warranty

- Two years

THREE MOUNTING OPTIONS:

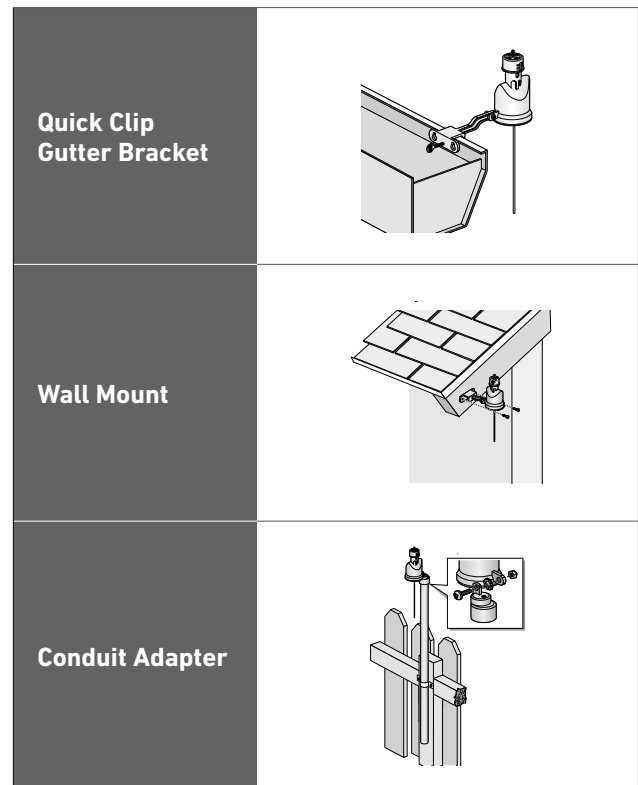

Specifying Information—Wired Sensor

Model	Description
TRS 53853	Toro Wired RainSensor Toro Wired Rain/Freeze Sensor

TFS FLOW SENSORS



The Toro® TFS series flow sensors provide reliable flow information to aid in the detection of and response to system issues like piping breaks, while being accurate enough for tracking water usage.

FEATURES & BENEFITS

Effective Flow Monitoring Even In Flows Lower Than 19 LPM

Effective in ranges from 4,5-1892,7 LPM. Teamed with the Toro TMC-424, 1/2", 3/4" and 1" sensors provide a cost-effective flow monitoring and alarm system.

Compatible With Competitive Controllers

In addition to the Toro compatible controllers – TDC+, TMC-424E and Sentinel® – these flow sensors work with any controller or control system compatible with frequency output flow sensors (pulses per second proportional to flow velocity).

Additional Features

- ✓ Simple, yet effective impeller-based design
- ✓ Potted electronics designed for valve box or underground applications
- ✓ Sensor pre-installed in tee
- ✓ Removable sensor design for easy replacement without removal of tee
- ✓ Socket end tee



SPECIFICATIONS

Operational

- Output: Two-wire, unscaled pulse – pulse width 5msec +/- 25%
- Frequency: 3.2 to 200 Hz
- Pressure Rating:
 - 1/2", 3/4" and 1": up to 10,3 Bar
 - 1 1/2", 2", 3" and 4": up to 6,8 Bar
- Temperature Rating: Up to 60° C
- Flow Range (Velocity):
 - 1/2", 3/4" and 1": 0,6-6,0m per second
 - 1 1/2", 2", 3" and 4": 0,1-9,1m per second
- Tee:
 - 1/2", 3/4" and 1": Schedule 40 PVC
 - 1 1/2", 2", 3" and 4": Schedule 80 PVC
- Sensor Housing: Potted, PPS
- Impeller:
 - 1/2", 3/4" and 1": 300SST
 - 1 1/2", 2", 3" and 4": Glass-filled nylon
- Shaft: Tungsten Carbide
- Bearing: UHMWPE
- Wires: 18AWG direct burial shielded cable

Warranty

- Two years

TFS SERIES FLOW SENSOR PERFORMANCE DATA

Sensor Model	TFS-050	TFS-075	TFS-100	TFS-150	TFS-200	TFS-300	TFS-400
Size	1/2"	3/4"	1.0"	1.5"	2.0"	3.0"	4.0"
K Value	00.78	0.1563	0.26112	1.699	2.8249	8.309	13.74283
Offset	0.9	0.9	1.2	-3.016	0.1435	0.227	0.23707

TFS SERIES MODEL LIST

Model	Description	Suggested Operating Range:
TFS-050-BSP	1/2" Flow Sensor	4,5-45 LPM
TFS-075-BSP	3/4" Flow Sensor	10,2-65 LPM
TFS-100-BSP	1" Flow Sensor	18,9-189 LPM
TFS-150-BSP	1 1/2" Flow Sensor	18,9-189 LPM
TFS-200-BSP	2" Flow Sensor	38-757 LPM
TFS-300-BSP	3" Flow Sensor	76-1135 LPM
TFS-400-FLG	4" Flow Sensor	151-1892 LPM

Specifying Information—TFS Sensor

TFS-XXX-XXX			
Model	Configuration		
TFS	XXX		XXX
TFS—Flow Sensor	050—1/2" Plastic Tee 075—3/4" Plastic Tee 100—1" Plastic Tee 150—1 1/2" Plastic Tee	200—2" Plastic Tee 300—3" Plastic Tee 400—4" Plastic Tee	BSP—BSP Threaded Inlet FLG—Flanged Inlet 4" Only

EVOLUTION® SMART CONNECT® REMOTE

FEATURES & BENEFITS

Compatible with EVOLUTION

Works with EVOLUTION Series Controllers outfitted with Smart Connect® receivers.

Backlit Display Handheld Remote

Makes maintenance checks easy after sunset with a backlit display.

Additional Features

- ✓ Provide individual zones or schedule ON/OFF schedules
- ✓ Mini USB port for upgrades to features or access to data
- ✓ Water resistant case
- ✓ Battery indicator
- ✓ Set the maximum zone count to match the controller



SPECIFICATIONS

Operational

- Up to 300 m range line of sight
- Address PIN range 0000-9999
- Watering and auxiliary modes

Electrical

- 9 V Battery

Temperature

- Operating -25°C to 60°C
- Storage -30°C to 65°C

Dimensions

- 17,7 x 9,5 x 3,1 cm

Warranty

- Five years

Specifying Information—Smart Connect® Remote

Model	Description
EVO-HH-EU	Smart Connect Handheld Remote

MICRO IRRIGATION FOR LANDSCAPE

Drip is one of the most efficient methods of irrigation.

With innovative products like Drip In[®] PC subsurface dripline with ROOTGUARD[®], Toro's line of landscape drip products takes watering efficiency to the next level.



TORO



MICRO IRRIGATION FOR LANDSCAPE

Pages 133-156

NEPTUNE PC - Woodland Brown	135
NEPTUNE HW - Woodland Brown	136
DRIP IN® PC Brown	137
DRIP IN® PC Camouflage Green	138
DRIP IN PC ROOTGUARD®	139-140
S-DRIP Brown	141
Polyethylene Hose	142
NGE® AL	143
White Spider	144
EURO PLUS	145
EURO KEY	146
Fogger	147
Bubbler	147
Varis™ & Varistake™	148
Trickler	148
Varijet/Accessories	149
Screen in-line filters	150
M Series Filters	150
S and F Series Filters	151
XD Series Filters	152
UNIVERSAL Valve Boxes	153-154
Pressure Regulators	155
Drip Line Fittings and PE Hose	156

NEPTUNE PC - WOODLAND BROWN

Pressure compensating flat emitter Drip line

Neptune PC – Woodland Brown is an ANTI-SIPHON drip line with built-in Pressure-Compensating emitter.

The emitter's pressure compensating mechanism always ensures:

- Efficient operation
- Uniform water distribution
- Multi-year durability.

Uniform distribution optimises results, as each plant receives the same amount of water



FEATURES

Pressure compensating system

It guarantees a constant flow rate even when pressure fluctuates (between 0.5 and 3.5 bar), ensuring water is distributed properly;

Highly resistant to clogging

The AS System reduces suction and prevents impurities from getting in

Outlet hole made using precision mechanical drilling

Drip line can also be installed below the surface

SPECIFICATIONS

- Diameter 16 mm
- Spacing 33 mm
- Emitter 2.4 l/h
- Max. operating pressure 3.5 bar
- 4 Coil lengths available: 25 m / 50 m / 100 m / 500 m



DIMENSIONS

DIAMETER	SPACING	MAX. OPERATING PRESSURE	COIL LENGTH	WEIGHT	COILDIMENSIONS (Ø X H)
16 mm	33 cm	3,5 bar	25 m	1,1 Kg	55 cm x 10 cm
			50 m	2,2 Kg	55 cm x 13 cm
			100 m	4,5 Kg	55 cm x 21 cm
			500 m	22,3 Kg	80 cm x 30 cm

Specifying Information - Neptune PC Woodland Brown

Model	Description
PPB163324025	Neptune PC - Woodland Brown 16mm 33cm, 2.4 l/h, 25 m
PPB163324050	Neptune PC - Woodland Brown 16mm 33cm, 2.4 l/h, 50 m
PPB163324100	Neptune PC - Woodland Brown 16mm 33cm, 2.4 l/h, 100 m
PPB163324	Neptune PC - Woodland Brown 16mm 33cm, 2.4 l/h, 500 m

NEPTUNE HW - WOODLAND BROWN

Flat emitter Drip line

Neptune HW - Woodland Brown is a drip line with flat emitter to irrigate gardens and hedges.

The turbulent flow emitter, which features wide passages, makes Neptune HW highly resistant to clogging. The use of high-quality polymers ensures longer durability and high resistance to possible mechanical damage.

Neptune HW is designed and built following the highest quality standards and it is an accessible, affordable investment that also ensures excellent performance.

FEATURES

Highly resistant to accidental impacts and/or collisions

Making it fast and easy to install (by reducing installation time and the corresponding labour costs, minimising the risk of damaging the product);

Highly resistant to clogging

Due to the turbulent flow emitter, featuring wide passages, and optimised for residential and landscaping applications.

Emitter's filter assures that sediment deposits do not get into the emitter;



SPECIFICATIONS

- Diameter 16 mm
- Spacing 33 mm
- Emitter 2.0 l/h
- Max. operating pressure 3.5 bar
- 4 Coil lengths available: 25 m / 50 m / 100 m / 500 m

Outlet hole made using precision mechanical drilling

Extrusion process with simultaneous insertion of emitter

Ensuring uniform dimensions and mechanical features

DIMENSIONS

DIAMETER	SPACING	MAX. OPERATING PRESSURE	COIL LENGTH	WEIGHT	COIL DIMENSIONS (Ø X H)
16 mm	33 cm	3,5 bar	25 m	1,1 Kg	55 cm x 10 cm
			50 m	2,2 Kg	55 cm x 13 cm
			100 m	4,5 Kg	55 cm x 21 cm
			500 m	22,3 Kg	80 cm x 30 cm

Specifying Information - Neptune HW Woodland Brown

Model	Description
PTB163320025	Neptune HW - Woodland Brown 16mm 33cm, 2.0 l/h, 25 m
PTB163320050	Neptune HW - Woodland Brown 16mm 33cm, 2.0 l/h, 50 m
PTB163320100	Neptune HW - Woodland Brown 16mm 33cm, 2.0 l/h, 100 m
PTB163320	Neptune HW - Woodland Brown 16mm 33cm, 2.0 l/h, 500 m

DRIP IN® PC BROWN

Pressure-compensating cylindrical emitter Drip line

Brown Drip In® PC is a drip line with pressure-compensating cylindrical emitter that is ideal for watering land and gardens that are not perfectly flat.

The Drip In® PC emitter ensures:

- Efficient operation;
- Uniform distribution;
- Multi-year durability.

Drip In® PC Brown can be installed above the surface or sub-surface.



FEATURES

Pressure-compensating system

Ensuring a constant flow rate even if pressure fluctuates

Highly resistant to clogging, as the emitter is designed to last several years:

- Self-cleaning diaphragm
- Raised inlet to make sure sediment deposits do not get into the emitter

Two outlets holes on opposite sides

Preventing impurities from being suctioned.

The shade of brown is particularly suited to blend in with flowerbeds and hedges

Excellent flexibility to shape the tubing as needed

Can be installed below the surface

SPECIFICATIONS

- Diameter 16 mm
- Spacing 33 mm
- Emitter 2.0 l/h
- Max. operating pressure 3.5 bar
- 4 Coil lengths available: 25 m / 50 m / 100 m / 400 m

DIMENSIONS

DIAMETER	SPACING	MAX. OPERATING PRESSURE	COIL LENGTH	WEIGHT	COIL DIMENSIONS (Ø X H)
16 mm	33 cm	3,5 bar	25 m	1,1 Kg	55 cm x 12 cm
			50 m	2,8 Kg	55 cm x 15 cm
			100 m	5,4 Kg	55 cm x 18 cm
			400 m	22,4 Kg	80 cm x 30 cm

Specifying Information - Drip In® PC Brown

Model	Description
EHDP162-33-25	Drip In PC Brown 16mm, 33cm, 2.0 l/h, 25 m
EHDP162-33-50	Drip In PC Brown 16mm, 33cm, 2.0 l/h, 50 m
EHDP162-33	Drip In PC Brown 16mm, 33cm, 2.0 l/h, 100 m
EHDP162-33-4A	Drip In PC Brown 16mm, 33cm, 2.0 l/h, 500 m

DRIP IN® PC CAMOUFLAGE GREEN

Pressure-compensating cylindrical emitter Drip line

Camouflage Green Drip In® PC is a drip line with a pressure-compensating cylindrical emitter that is ideal for low visibility applications. Like the brown version, the Drip In® PC emitter ensures:

- Clog resistance;
- Uniform distribution;
- Multi-year durability.

Camouflage Green Drip In® PC can be installed above the surface.

This shade of green is the result of important colour studies in order to obtain a colour that blends in perfectly both on lawns and along hedges. Being matte, it also has a minimal impact on the environment and is pleasing to the eye.



SPECIFICATION

- Diameter 16 mm
- Spacing 33 mm
- Emitter 2.0 l/h
- Max. operating pressure 4.0 bar
- 2 Coil lengths available: 25 m / 50 m / 100 m

FEATURES

Pressure-compensating system

Ensuring a constant flow rate even if pressure fluctuates

Highly resistant to clogging, as the emitter is designed to last several years:

- Self-cleaning diaphragm
- Raised inlet to make sure sediment deposits do not get into the emitter

Two outlet holes on opposite sides

Preventing impurities from being suctioned.

The shade of green is particularly suited to blend in with flowerbeds and hedges

Excellent flexibility to shape the tubing as needed

DIMENSIONS

DIAMETER	SPACING	MAX. OPERATING PRESSURE	COIL LENGTH	WEIGHT	COIL DIMENSIONS (Ø X H)
16 mm	33 cm	4,0 bar	25 m	1,5 Kg	52 cm x 12 cm
			50 m	2,8 Kg	55 cm x 15 cm
			100 m	5,4 Kg	55 cm x 18 cm

Specifying Information - Drip In® PC Camouflage Green

Model	Description
EHDPC162-33-25	Drip In PC Camouflage Green 16mm, 33cm, 2.0 l/h, 25 m
EHDPCG162-33-50	Drip In PC Camouflage Green 16mm, 33cm, 2.0 l/h, 50 m
EHDPCG162-33	Drip In PC Camouflage Green 16mm, 33cm, 2.0 l/h, 100 m

DRIP IN® PC ROOTGUARD®

Pressure-compensating cylindrical emitter Drip line

Drip In® PC RootGuard® was created with the goal of being the most effective, efficient lawn irrigation system.

The cutting-edge turbulent flow pressure-compensating emitter used in Drip In® PC is guaranteed to prevent the risk of clogging in systems installed below the surface.

ROOTGUARD® technology, in which weed killer is released evenly over a long period of time and maintains a sufficient concentration in the terrain adjacent to the drip line, definitively removes the risk of roots growing and intruding into the emitter. The combination of Drip In® PC and RootGuard® technology is a winning match to ensure a drip irrigation system with no risk of clogging or malfunctioning and the advantage of a completely free lawn that can be used at any time.



SPECIFICATIONS

- Diameter 16 mm
- Spacing 33 mm
- Emitter 2.0 l/h
- Max. operating pressure 4.0 bar
- 2 Coil Lengths available: 100 m / 400 m

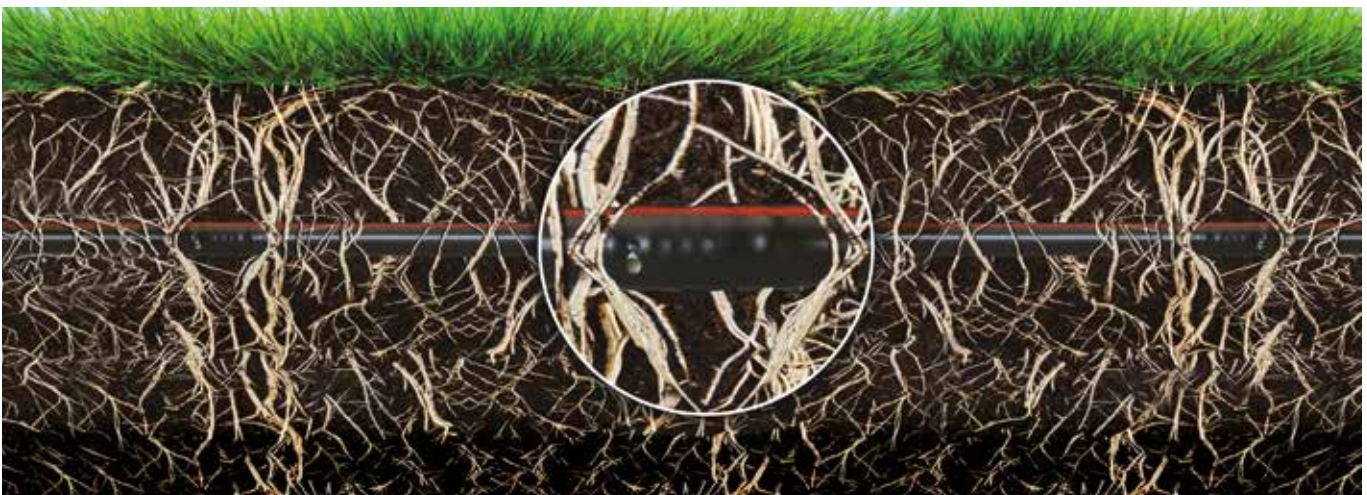

ADVANTAGES OF SUBSURFACE IRRIGATION

Greater yields

Water and nutrients are delivered at regular intervals directly where the roots are located, thereby promoting healthy plant growth and reducing stress.

Significant water saving

Improved irrigation efficiency combined with the option of programming brief, frequent irrigation times eliminates washout and deep percolation. It also eliminates water loss due to evaporation.

Healthier plants and higher quality lawns

The surface of the ground, lawn and leaves remains dry.

Better soil aeration

Fine soil particles are not washed out, reducing soil compaction and promoting root growth.

Longer irrigation system durability

Drip In® PC is made with resistant polymers. When installed in-ground, the system is protected from ultraviolet rays and fluctuating temperatures.

Larger irrigated soil volume

With subsurface irrigation, water can also go upward by capillarity and in all directions, resulting in an increase of up to 46% in irrigated soil volume

Dry soil surface

As the surface is dry, the lawn can be used at any time, regardless of the watering schedule.

DIMENSIONS

DIAMETER	SPACING	MAX. OPERATING PRESSURE	COIL LENGTH	WEIGHT	COIL DIMENSIONS (Ø X H)
16 mm	33 cm	4,0 bar	100 m	5,4 Kg	59 cm x 18 cm
			400 m	22,8 Kg	80 cm x 30 cm

Specifying Information DRIP IN PC with Rootguard

Model	Description
EHDPCR162-33	Drip In PC RootGuard 16mm, 33cm, 2,0 l/h, 100 m
EHDPCR162-33-4A	Drip In PC RootGuard 16mm, 33cm, 2,0 l/h, 400 m

S-DRIP BROWN

Cylindrical emitter Drip line

S-Drip Brown is a drip line with cylindrical emitter ideal for watering gardens and hedges.

The S-Drip emitter ensures:

- Clog resistance;
- Durability;
- Excellent irrigation on flat land.

Brown S-Drip is designed and built following the highest quality standards and is an accessible, convenient investment that ensures perfect irrigation.

Brown S-Drip can be installed above ground.



FEATURES

Highly resistant to clogging, as the emitter is designed to last several years:

Highly resistant to accidental impacts due to the use of machinery or simple collisions

This resistance makes it even easier to install

The shade of brown is particularly suited to blend into flowerbeds and hedges;

Excellent flexibility to shape the tubing as needed.

SPECIFICATIONS

- Diameter 16 mm
- Spacing 33 mm
- Emitter 2.0 l/h
- Max. operating pressure 3.5 bar
- 4 Coil lengths available: 25 m / 50 m / 100 m / 400 m

DIMENSIONS

DIAMETER	SPACING	MAX. OPERATING PRESSURE	COIL LENGTH	WEIGHT	COIL DIMENSIONS (Ø X H)
16 mm	33 cm	3,5 bar	25 m	1,6Kg	55 cm x 12 cm
			50 m	3,2 Kg	58 cm x 15 cm
			100 m	6,5 Kg	59 cm x 18 cm
			400 m	26 Kg	83 cm x 30 cm

Specifying Information S-Drip Brown

Model	Description
SB162-33-25	S-Drip Brown 16mm, 33cm, 2,0 l/h, 25 m
SB162-33-50	S-Drip Brown 16mm, 33cm, 2,0 l/h, 50 m
SB162-33-100	S-Drip Brown 16mm, 33cm, 2,0 l/h, 100 m
SB162-33	S-Drip Brown 16mm, 33cm, 2,0 l/h, 400 m

POLYETHYLENE HOSE

Oval and Circular Cross-section Polyethylene Hose

The low-density polyethylene hose is manufactured with select polymers to ensure reliability and affordability. The composition offers long-term durability in the most adverse weather conditions. The mechanical features of the polyethylene hose allow the on-line emitters to be inserted easily and safely.



FEATURES

The low-density polyethylene hose features:

- Long-term durability in the harshest operating conditions;
- Easy to insert on-line emitters like Euro Key / Euro Plus / NGE AL

SPECIFICATIONS

The range of low-density polyethylene hose includes:

- Diameter 16 mm:
 - Wall thickness 0.9* and 1.1 mm
- Diameter 20 mm:
 - Wall thickness 0.9* and 1.2 mm
- The circular cross-section (EHD codes) makes it easier to insert on-line emitters (Euro Key / Euro Plus / NGE)
- The oval cross-section (PHW codes) makes it especially suitable to connect the mains lines to the drip lines.
- Available colours:
 - White and Brown for the circular cross-section (EHD codes)
 - Black with a blue stripe for the oval cross-section (PHW codes)

* The 0.9 mm wall thickness is only available for oval cross-section hose (PHW codes)

APPLICATIONS

- The low-density polyethylene hose transports water and nutrients in all applications in which using on-line emitters is preferable or when creating secondary lines.
- White hose is highly recommended when irrigating balconies, as it has the same features and performance as the black one but is also considerably less visible and gives a pleasant clean-cut effect.

CIRCULAR CROSS-SECTION POLYETHYLENE TUBING DIMENSIONS (EHD CODES)

DIAMETER	THICKNESS	MAX. OPERATING PRESSURE	COIL LENGTH	WEIGHT	COIL DIMENSIONS (Ø X H)
16 mm	1,1 cm	4,0 bar	50 m	2,5 Kg	55 cm x 15 cm
			400 m	20,0 Kg	55 cm x 32 cm
20 mm	1,2 cm	4,0 bar	50 m	3,3 Kg	55 cm x 15 cm
			300 m	19,5 Kg	55 cm x 32 cm

OVAL CROSS-SECTION POLYETHYLENE TUBING DIMENSIONS (PHW CODES)

DIAMETER	THICKNESS	MAX. OPERATING PRESSURE	COIL LENGTH	WEIGHT	COIL DIMENSIONS (Ø X H)
16 mm	0,9 cm	3,5 bar	500 m	21,0 Kg	80 cm x 30 cm
	1,1 cm	4,0 bar		25,5 Kg	
20 mm	0,9 cm	3,0 bar	370 m	18,0 Kg	80 cm x 30 cm
	1,2 cm	4,0 bar	340 m	22,0 Kg	

Specifying Information - Polyethylene Hose

Model	Description
EHDW16-50	White circular cross-section polyethylene hose, 16mm, 1.1mm, 50 m
EHDW16-400	White circular cross-section polyethylene hose, 16mm, 1.1mm, 400 m
EHDW20-50	White circular cross-section polyethylene hose, 20mm, 1.2mm, 50 m
EHDW20-300	White circular cross-section polyethylene hose, 20mm, 1.2mm, 300 m
EHDB16-50	Brown circular cross-section polyethylene hose, 16mm, 1.1mm, 50 m
EHDB20-50	Brown circular cross-section polyethylene hose, 20mm, 1.2mm, 50 m
PHW1609	Black oval cross-section polyethylene hose, 16mm, 0.9mm, 500 m
PHW1611	Black oval cross-section polyethylene hose, 16mm, 1.1mm, 500 m
PHW2009	Black oval cross-section polyethylene hose, 20mm, 0.9mm, 370 m
PHW2012	Black oval cross-section polyethylene hose, 20mm, 1.2mm, 340 m

NGE® AL

Pressure-Compensating Anti-Leak Dripper



The NGE® AL dripper is ideal for watering potted plants on balconies or terraces and for any other applications requiring punctual, accurate irrigation. Each emitter supplies an accurate amount, while the anti-leak device prevents leaking once the system is shut off.



FEATURES

The dripper design and pressure compensating membrane means:

- The dripper open once a pressure of 0.9 bar is reached. As a result, system operating time is reduced to a minimum with the utmost distribution uniformity.
- Self-cleaning while the system is operating.
- The drippers close when pressure reaches values between 0.24 and 0.34 bar, depending on the flow rate. This prevents the system from draining, allowing for short, efficient irrigation cycles.
- The drippers close once the system stops, preventing due to suction of impurities.

The semi-circular cross-section intake filter and large transversal cross-section labyrinth ensure the system is highly resistant to clogging.

Coefficient of Variation (CV) ≤3%.

Available with Male Adapter (-MA) for Spider with single or double outlets.

ISO 9261:2004 standard compliant

DRIPPER FLOW RATE VS. PRESSURE

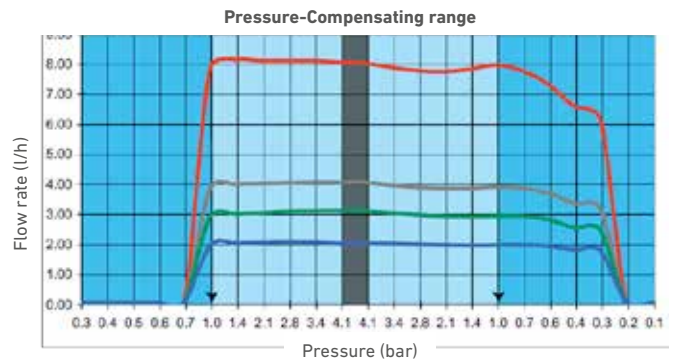

- Light blue 2,0 l/h
- Light green 3,0 l/h
- Grey 4,0 l/h
- Light red 8,0 l/h

TECHNICAL DATA

NGE® AL Specifications		DPCT02	DPCT03	DPCT04	DPCT08
Nominal Flow Rate	l/h	2,0	3,0	4,0	8,0
Pressure-Compensating range	bar	from 0,9 to 4,1			
Closing pressure	bar	0,24	0,28	0,34	0,34
Coefficient of Variation (Cv)		3%			
Minimum Required Filtration		140 Mesh (105 Micron)			
Colour / Colour Code		Blue / BLUE	Green / GRN	Grey / BLK	Red / RED

Specifying Information - NGE® AL

Model	Description
DPCT02-MA-AL-BLUE	NGE Anti-Leak 2 l/h with male adapter
DPCT03-MA-AL-GRN	NGE Anti-Leak 3 l/h with male adapter
DPCT04-MA-AL-BLK	NGE Anti-Leak 4 l/h with male adapter
DPCT08-MA-AL-RED	NGE Anti-Leak 8 l/h with male adapter

WHITE SPIDER

Starting from an on-line dripper, Spider assemblies distribute water directly into pots.

FEAUTURES

- Accurate, punctual water distribution
- Available in two configurations with 1 or 2 outlets
- Available with 60 or 80 cm microtube
- Easy to install on NGE emitters with male adaptor (-MA).
- Microtube: 3 x 5 mm
- Also available in the version with black microtube and stake

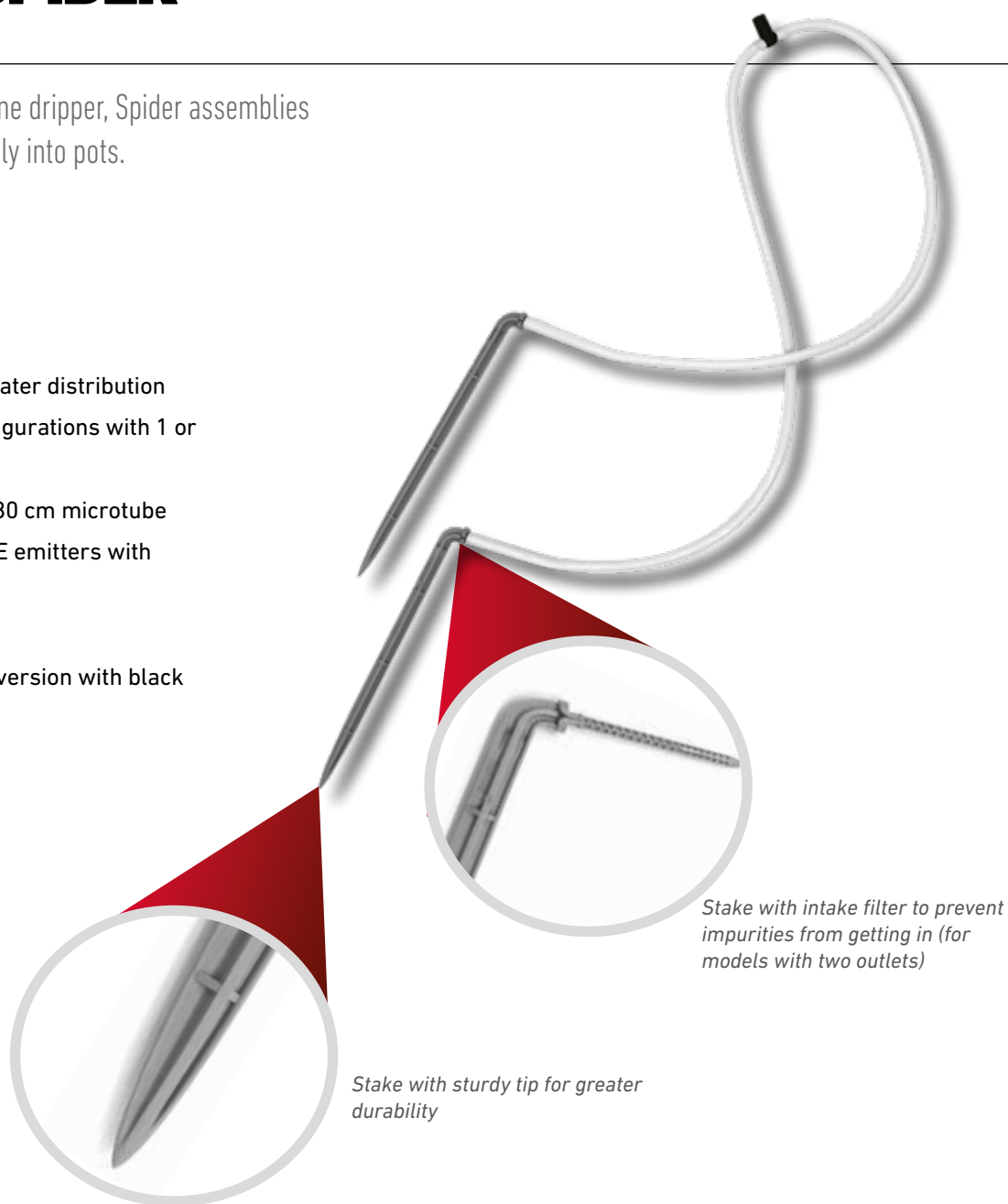

Elbow barbed stake for single outlet Spider



Elbow labyrinth stake for double outlet Spider

Specifying Information - WHITE SPIDER

Model	Adaptor	Microtube	Stake
1-Outlet WHITE SPIDER			
IT-DBS1WQBX-60	1-outlet straight	1 x 60 cm White	1 x Grey 90° barbed Stake
IT-DBS1WQBX-80	1-outlet straight	1 x 80 cm White	1 x Grey 90° barbed Stake
2-Outlets WHITE SPIDER			
IT-DBS2WQTX-60	2-outlets Tee	2 x 60 cm White	2 x Grey 90° Turbulent Flow Stake
IT-DBS2WQTX-80	2-outlets Tee	2 x 80 cm White	2 x Grey 90° Turbulent Flow Stake

EURO PLUS

Pressure-Compensating Maintainable Dripper



FEATURES

- Maintainable dripper that allows quick and easy system maintenance.
- Base with fins to keep the dripper in position along the drip line.
- Silicone membrane
- 4 mm barbed inlet.
- Male output with connector for 4x6mm microtube.



SPECIFICATIONS

- Nominal flow rate: 4, 8 and 16 l/h.
- Pressure-Compensating range: 1,0-3,0 Bar
- Coefficient of Variation (CV) ≤5%.
- Recommended filtration: 150 mesh.
- ISO 9261:2004 compliant.

PERFORMANCE

Code	FLOW RATE in l/h @				
	1,0 bar	1,5 bar	2,0 bar	2,5 bar	3,0 bar
IT-DPJ04-2	4,2	4,3	4,6	4,7	4,6
IT-DPJ08-2	8,2	9,0	9,2	9,1	8,7
IT-DPJ15-2	12,2	14,0	15,5	16,5	15,5



Black Base nominal flow rate 4 l/h



Red Base nominal flow rate 8 l/h



Brown Base nominal flow rate 16 l/h

Specifying Information - EURO PLUS

Modello	Descrizione
IT-DPJ04-2	Euro-Plus, Maintainable Dripper with 4 l/h flow rate
IT-DPJ08-2	Euro-Plus, Maintainable Dripper with 8 l/h flow rate
IT-DPJ15-2	Euro-Plus, Maintainable Dripper with 16 l/h flow rate

EURO KEY

Maintainable Dripper

FEATURES

- Maintainable dripper that allows for easy system monitoring
- Base with fins to keep the drip line stable
- Coefficient of Variation (CV) $\leq 5\%$
- Large turbulent labyrinth that creates high resistance to clogging
- Key available (EU-DNK00)
- ISO 9261:2004 compliant



SPECIFICATION

- Nominal flow rate: 2, 4, 8, 16, 24 l/h
- Recommended operating pressure: 1.0-2.0 bar
- CV $\leq 5\%$
- Inlet: 4mm barbed connector
- Male output with connector for 4x6 mm microtube

PERFORMANCE

Model	Disc Colour	Flow Rate in l/h @		
		1,0 bar	1,25 bar	1,5 bar
Euro-Key 2 l/h	White	2,0	2,4	2,8
Euro-Key 4 l/h	Black	4,0	5,0	5,6
Euro-Key 8 l/h	Green	8,0	9,7	11,2
Euro-Key 16 l/h	Red	16,0	16,8	19,5
Euro-Key 24 l/h	Yellow	24,7	29,0	34,0

Specifying Information - EURO KEY

Model	Description
EU-DNK02-2-BLUE	Euro Key 2 l/h, dripper with blue base
EU-DNK04-2	Euro Key 4 l/h, dripper with black base
EU-DNK08-2-RED	Euro Key 8 l/h, dripper with red base
EU-DNK16-2-MB	Euro Key 16 l/h, dripper with brown base
EU-DNK24-2-GREEN	Euro Key 24 l/h, dripper with green base

FOGGER



APPLICATIONS

Foggers are suitable for nurseries, shrubs, and trees requiring a fine low-pressure, low-flow rate mist and allow for temperature and moisture control.

FEATURES

- Available in 3 flow rates, respectively: 8, 12, and 16 l/h
- Available in 2 easy to install versions with 4 mm barbed (SFJ) and 3/8" threaded (SFL) connectors.
- Operating pressure from 0.75 to 2.25 bar
- Diameter from 0.6 to 1.5 m
- SFJ barbed connector attaches directly to PE tubing



Specifying Information - FOGGER

Model	Description
SFJ408	Fogger, 8 l/h with 4mm barbed connector
SFJ412	Fogger, 12 l/h with 4mm barbed connector
SFJ416	Fogger, 16 l/h with 4mm barbed connector
SFL408	Fogger, 8 l/h with male 3/8" threaded connector
SFL412	Fogger, 12 l/h with male 3/8" threaded connector
SFL416	Fogger, 16 l/h with male 3/8" threaded connector

BUBBLER™

APPLICATIONS

Local irrigation of flower pots, flowerbeds, individual plants and shrubs.

FEATURES

- Flow rate adjustable from 0 to 400 l/h
- Operating pressure from 1 to 3 bar
- Easy flow rate adjustment
- ½" female thread



Specifying Information - BUBBLER

Model	Description
EU-SHW401-2N	Bubbler, flood

VARIS™ AND VARISTAKE™



APPLICATIONS

Irrigating potted plants, flowerbeds in residential and landscaping settings, on balconies, patios and terraces.

FEATURES

- Flow rate adjustable from 0 to 40 l/h
- 8 outlet holes for a more even distribution of water at 360°
- Accurate flow rate regulation with ratchet mechanism
- Easy to inspect
- Operating pressure: 0.75-2.25 bar
- Microtube PE hose barbed connector supplied along with Varistake
- Varis can be installed directly on the PE hose or at the end of the microtube
- Varistake can be planted into the ground thanks to the incorporated 12cm stake



SPECIFICATIONS

- 4 mm barbed connection (Varis)
- 4 mm barbed connection installed on 12 cm stake (Varistake)

Specifying Information - VARIS and VARISTAKE

Model	Description
EU-DAK05	Varis, 0-40 l/h, 4 mm barbed
EU-DAK15	Varistake, 0-40 l/h, 4 mm barbed installed on 12 cm stake

TRICKLER



APPLICATIONS

Irrigating potted plants, flowerbeds in residential and landscaping settings, on balconies, patios, and terraces.

FEATURES

- Flow rate adjustable from 0 to 30 l/h
- 12 outlet holes for a more uniform distribution of water at 360°
- Accurate flow rate regulation with ratchet mechanism
- Easy to inspect
- Operating pressure: 0.75-2.25 bar



SPECIFICATIONS

- Connection with 4mm male threaded

Specifying Information - TRICKLER

Model	Description
1011292	Trickler, 0-30 l/h, 4 mm male threaded

VARIJET

APPLICATIONS

Flowerbed and garden irrigation

FEATURES

- Flow rate adjustable from 0 to 53 l/h
- Operating pressure: 0.5-2.5 bar
- Radius from 1.25 to 2.90 m
- 3 models available with 360° x 15, 180°, and 90° trajectories
- Easy to install on PE hose



PERFORMANCE

Pressure (bar)	Flow rate (l/h)	SBB601	SBB607	SBB609
		360°x15	180°	90°
		Radius (m)		
0,5	22	1,25	1,70	1,70
1,0	32	1,55	1,80	1,80
1,5	40	1,75	2,05	2,05
2,0	47	1,90	2,45	2,45
2,5	53	1,95	2,90	2,90

Specifying Information - VARIJET

Model	Description
SBB601	Varijet, 360° micro sprinkler
SBB607	Varijet, 180° micro sprinkler°
SBB609	Varijet, 90° micro sprinkler

ACCESSORIES

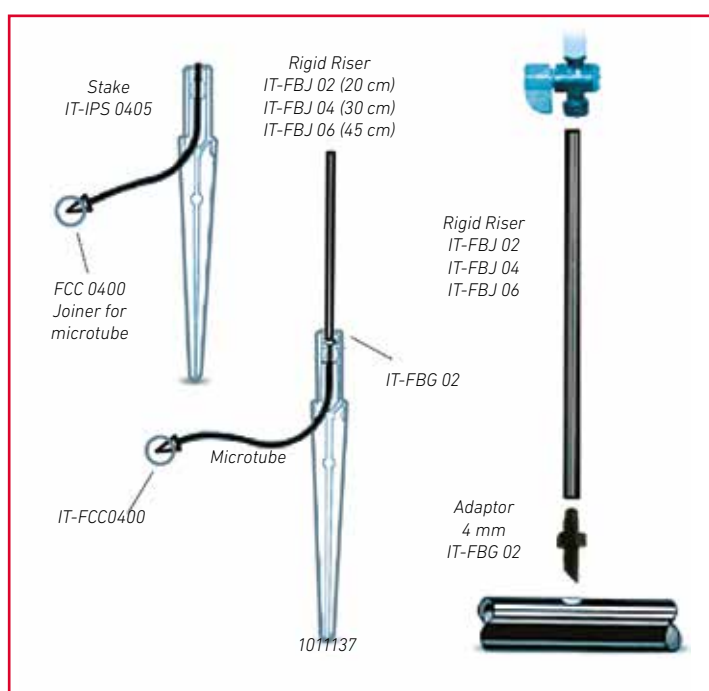

IN-LINE SCREEN FILTERS

FEATURES

- Two models available
- Maximum operating pressure: 3 bar
- 80-mesh screen cartridge
- Direction of flow marked on the body



Specifying Information - IN-LINE SCREEN FILTERS

Model	Description
1011111B	In-line filter for 16 mm external Ø tubing, 2x13 mm Ø barbed connections, 80 mesh
1011113B	In-line filter for 25 mm external Ø tubing, 2x19 mm Ø barbed connections, 80 mesh

M SERIES FILTERS

Small plastic filters

FEATURES

- Cartridge:
 - 150-mesh stainless steel screen
 - 150-mesh plastic discs
- Polypropylene body and cover, glass fibre reinforced Nylon locking ring
- Filtering surface:
 - 135 cm² screen cartridge
 - 170 cm² disc cartridge
- ½" male output (with optional cap) for quick self-cleaning



Specifying Information - M Series Filters

Model	Description
EU-ABF2015-2MW	M ¾" male filter, screen, 150 mesh without discharge
EU-ABF2515-2MW	M 1" male filter, screen, 150 mesh without discharge
EU-ABF3215-2MW	M 1 ¼" male filter, screen, 150 mesh without discharge
EU-ABF4015-2MW	M 1 ½" male filter, screen, 150 mesh without discharge
EU-ABF2015-3MW	M ¾" male filter, disc, 150 mesh without discharge
EU-ABF2515-3MW	M 1" male filter, disc, 150 mesh without discharge
EU-ABF3215-3MW	M 1 ¼" male filter, disc, 150 mesh without discharge
EU-ABF4015-3MW	M 1 ½" male filter, disc, 150 mesh without discharge

SPECIFICATIONS

- ¾" to 1" ½ male thread
- Maximum operating pressure: 10 Bar

TECHNICAL FEATURES

Model	Screen Filters	Discs Filters	Inlet/outlet Male	Micron	Mesh	Max Flow Rate (l/m)
M20	EU-ABF2015-2MW	EU-ABF2015-3MW	¾"	100	~ 150	100
M25	EU-ABF2515-2MW	EU-ABF2515-3MW	1"	100	~ 150	120
M32	EU-ABF3215-2MW	EU-ABF3215-3MW	1 ¼"	100	~ 150	180
M40	EU-ABF4015-2MW	EU-ABF4015-3MW	1 ½"	100	~ 150	250

The maximum flow rates shown in the table refer to a pressure drop of 0.5 bar (clean water)

S AND F SERIES FILTERS

Small plastic filters

FEATURES

- Cartridge:
 - 150-mesh stainless steel screen
 - 150-mesh plastic discs
- Polypropylene body and cover, glass fibre reinforced Nylon locking ring
- Filtering surface:
 - 114 cm² screen cartridge (S Filter)
 - 225 cm² screen cartridge (F Filter)
 - 280 cm² disc cartridge (F Filter)
- Easy to disassemble for simple cleaning
- ½" male output (with optional cap) for quick self-cleaning



SPECIFICATIONS

- ¾" to 1 ½" male thread
- Maximum operating pressure: 10 Bar

TECHNICAL FEATURES

Model	Screen Filters	Discs Filters	Inlet/outlet Male	Micron	Mesh	Max Flow Rate (l/m)
F20-S	EU-ABF2015-2SW	-	¾"	100	~ 150	80
F25-S	EU-ABF2515-2SW	-	1"	100	~ 150	80
F25	EU-ABF2515-2FW	EU-ABF2515-3FW	1"	100	~ 150	200
F32	EU-ABF3215-2FW	EU-ABF3215-3FW	1" ¼"	100	~ 150	250
F40	EU-ABF4015-2FW	EU-ABF4015-3FW	1" ½"	100	~ 150	300

The maximum flow rates shown in the table refer to a head loss of 0.5 bar (clean water)

Specifying Information - S and F SERIES FILTERS

Model	Description
EU-ABF2015-2SW	¾" male S filter, screen, 150 mesh without discharge
EU-ABF2515-2SW	1" male S filter, screen, 150 mesh without discharge
EU-ABF2515-2FW	1" male F filter, screen, 150 mesh without discharge
EU-ABF3215-2FW	1" ¼ male F filter, screen, 150 mesh without discharge
EU-ABF4015-2FW	1" ½ male F filter, screen, 150 mesh without discharge
EU-ABF2515-3FW	1" male F filter, disc, 150 mesh without discharge
EU-ABF3215-3FW	1" ¼ male F filter, disc, 150 mesh without discharge
EU-ABF4015-3FW	1" ½ male F filter, disc, 150 mesh without discharge

XD SERIES FILTERS

Large plastic filters

FEATURES

- Innovative disc design
- Disc cartridge: 120, 150, 200 mesh
- Glass fibre reinforced Nylon body, lid and locking ring
- Filtering surface:
 - Short body 2" and 3" model: 10,800 cm²
 - 3" model: 18,000 cm²
- Ring nut closure with stop for easy tool-free assembly/disassembly
- Pressure gauge connections to be perforated as required, to allow measurement of pressure and thus the cleanliness of the filter
- The filter allows very long cleaning intervals



SPECIFICATIONS

- Male 1" thread to drill to use the air release valves
- Maximum operating pressure: 10 Bar
- 2 gauge mounting points: 1/4" female Gas
- Nominal flow rates:
 - 2" model: 25 m³/h
 - 3" model (short and long cover): 50 m³/h
- Dimensions:
 - 2" model: L 274 mm; H 540 mm
 - 3" model: L 320 mm; H 785 mm

2" Head Loss Table

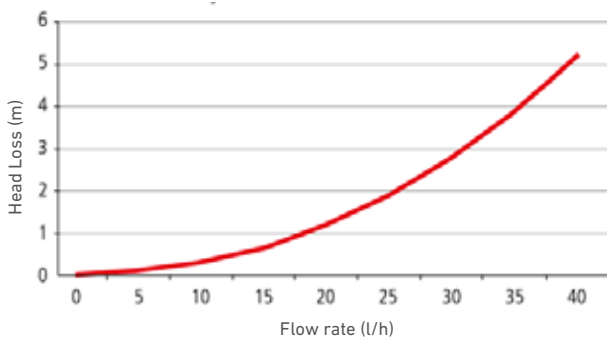

3" Head Loss Table

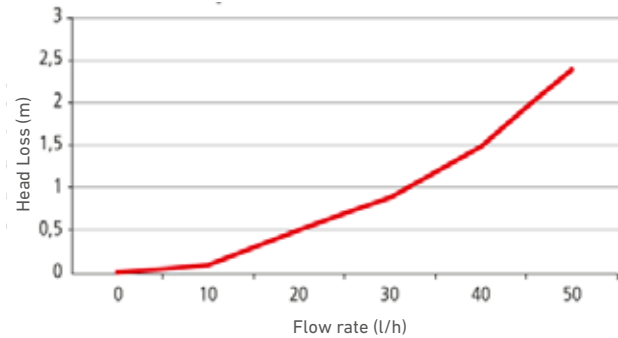

ADVANTAGE

The innovative XD disc design allows for a very ample filtering surface compared to a conventional disc filter, thereby ensuring high filtering capacity.

Specifying Information - XD Series Filters

Model	Description
EU-ABF5012-3X	2" XD disc filter, 120 mesh
EU-ABF5015-3X	2" XD disc filter, 150 mesh
EU-ABF5020-3X	2" XD disc filter, 200 mesh
EU-ABF7512-3XS	3" XD short cover disc filter, 120 mesh
EU-ABF7515-3XS	3" XD short cover disc filter, 150 mesh
EU-ABF7520-3XS	3" XD short cover disc filter, 200 mesh
EU-ABF7512-3X	3" XD disc filter, 120 mesh
EU-ABF7515-3X	3" XD disc filter, 150 mesh
EU-ABF7520-3X	3" XD disc filter, 200 mesh

UNIVERSAL VALVE BOXES

FEATURES

- ✓ *Resistance*
- ✓ *Versatility*
- ✓ *Range in line with the standard EN124, designed to support loads of up to 1.5 tons*

Circular Model

- Lid
 - Convenient 2-hole handle, with closing direction indication
 - Bayonet coupling system, with optional locking screw
 - Circular edge covering the body, rapid positioning, protection against water/soil entry
 - Anti-slip surface
 - Grass green colour
- Body:
 - Conical shape, for guaranteed stability in the ground
 - Reinforced wall thickness to protect against structural collapse
 - Ready-to-use and easily enlargeable tubing inlets

Rectangular Model

- Lid:
 - Access handle for easy opening
 - Edge covering the body, rapid positioning, protection against water/soil entry
 - Optional locking screwsystem
 - Anti-slip surface
 - Grass green colour
- Body:
 - Oblique shape for guaranteed stability in the ground
 - Innovative design to quickly, safely make holes on-site without using electricity
 - Reinforced angles to protect against structural collapse



Patented design: UAMI No. 002417675

Specifying Information - UNIVERSAL VALVE BOXES*

Model	Description
EU-TUCS	Toro Universal valve box Small Circular
EU-TUCM	Toro Universal valve box Medium Circular
EU-TURS	Toro Universal valve box Standard Rectangular
EU-TURJ	Toro Universal valve box Jumbo Rectangular

*Optional locking system using kit code EU-HCK or EU-HRK

Specifying Information - LIDS for UNIVERSAL VALVE BOXES*

Model	Description
EU-TUCSL	Lid for Small circular valve box
EU-TUCML	Lid for Medium circular valve box
EU-TURSL	Lid for Standard rectangular valve box
EU-TURJL	Lid for Jumbo rectangular valve box

*Locking kit not included

Specifying Information - ACCESSORIES for UNIVERSAL VALVE BOXES

Model	Description
EU-HRC	Cable holder for Rectangular models
EU-HRK	Locking Kit for rectangular (hexagonal bolt M6x25 + clamping nut model M6 G 24x16x11)
EU-HCK	Locking kit for circular models (screw M5x35 + hexagonal nut M5x8)

DIMENSIONS OF UNIVERSAL VALVE BOXES

Circular Models

The dimensions are in cm

SMALL CIRCULAR



MEDIUM CIRCULAR



Rectangular Models

The dimensions are in cm

STANDARD RECTANGULAR

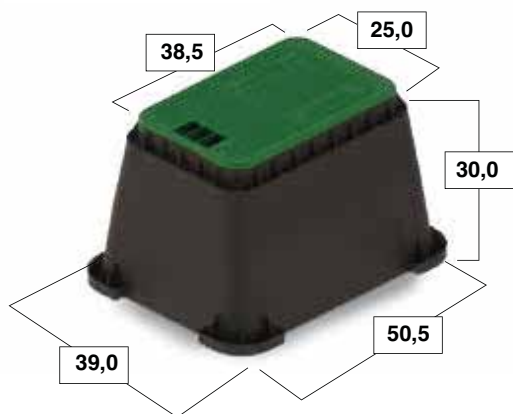

JUMBO RECTANGULAR



PRESSURE REGULATORS

FEATURES

- Ideal for areas with low irrigating pressure and pressure variation along the line
- The piston-valve assembly is made of DuPont Zytel for greater durability and constant operation
- Body in high quality ABS plastic, sonic welded for extra security
- Silicone O-ring for reduced pressure loss
- Stainless steel return springs



SPECIFICATIONS

- Thread: 3/4" male and female
- Operating pressure: 1.4 – 7.0 Bar











PERFORMANCE

Inlet pressure (Bar)	Outlet pressure (Bar) Model 15					Outlet pressure (Bar) Model 19					Outlet pressure (Bar) Model 25				
1,4	0,87	1,22	1,07	0,90	0,87	1,04	1,30	1,03	0,76	0,57	1,33	1,36	1,30	1,20	1,06
2,1	1,21	1,38	1,35	1,19	1,19	1,34	1,50	1,39	1,05	0,79	2,02	1,92	1,78	1,63	1,47
2,8	1,44	1,42	1,35	1,24	1,22	1,51	1,58	1,51	1,33	1,03	2,08	2,01	1,90	1,80	1,69
3,4	1,48	1,43	1,34	1,25	1,19	1,59	1,56	1,51	1,41	1,23	2,13	2,01	1,91	1,82	1,73
4,1	1,47	1,45	1,32	1,23	1,18	1,61	1,55	1,48	1,41	1,34	2,14	2,01	1,92	1,80	1,72
4,8	1,47	1,46	1,32	1,19	1,15	1,59	1,52	1,46	1,37	1,30	2,14	1,97	1,93	1,77	1,69
5,5	1,47	1,46	1,32	1,17	1,13	1,59	1,51	1,44	1,35	1,26	2,09	1,97	1,92	1,76	1,67
6,2	1,46	1,49	1,31	1,16	1,15	1,55	1,49	1,41	1,35	1,26	2,07	1,88	1,95	1,75	1,66
6,9	1,44	1,46	1,31	1,16	1,15	1,50	1,48	1,38	1,32	1,23	2,01	1,88	1,95	1,75	1,63
l/min	3,8	7,6	15,1	22,7	30,3	3,8	7,6	15,1	22,7	30,3	3,8	7,6	15,1	22,7	30,3

Specifying Information - PRESSURE REGULATORS

Model	Description
IT-VRR2020151	Pre-set pressure regulator 3/4", model 15
IT-VRR2020191	Pre-set pressure regulator 3/4", model 19
IT-VRR2020251	RPre-set pressure regulator 3/4", model 25

DRIP LINE FITTINGS AND PE HOSE

	MODEL	DESCRIPTION
	IT-FCC617	Fitting for 16 mm dripline
	IT-FCC618	Fitting for 20 mm dripline
	IT-FTT612	Tee fitting for 16x16x16mm dripline
	IT-FTT616	Tee fitting for 20x20x20mm dripline
	IT-FGA6191	3/8" male threaded starter for 16mm dripline
	IT-FGA6192	3/8" male threaded starter for 20mm dripline
	IT-FGA619	10mm barbed starter for 16mm dripline
	IT-FGA620	10mm barbed starter for 20mm dripline
	1011231 1011233	Line end cap for 16mm dripline Line end cap for 20mm dripline
	IT-IPS1501	Anchoring stake for 16mm dripline
	IT-FMP457	7mm punch tool for 10mm connections





CENTRAL CONTROL

Pages 157-164

TriComm™ System	159-160
Sentinel® Central Control	161-162
National Support Network (NSN®)	163

The Toro TriComm™ System is a Remote Site Management Tool for Irrigation Systems, using an Internet-based control interface over a GPRS cellular network.

FEATURES & BENEFITS

Internet-based Software

Access the TriComm System from any Web-connected computer or WAP-enabled PDA or mobile phone.

Automatic ET-Adjustment

System connection to a weather station provides the ability for automatic runtime adjustment by daily ET.

E-mail or Text message Alerts

Customizable e-mail or text message alerts for real-time notification of controller alarms.

Two-Way Communications

All communications occur through state-of-the-art cellular network with real-time indication of controller connectivity. Controller Status shows currently operating programs and stations with irrigation time remaining.

Water Use Reports

Comprehensive reporting provides theoretical water consumption reports based on controller learned flow per station versus daily runtime.

Toro NSN® Support

TriComm comes with a minimum of one-year of NSN Support – unlimited toll-free support with 24/7/365 emergency paging.

Additional Features

- ✓ Remote Site Management
- ✓ Internet-based Software
- ✓ Auto ET-Adjust
- ✓ Theoretical Water Use Reports

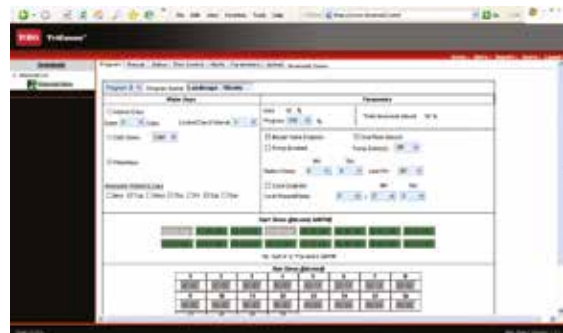

TriComm Modem Kit

TMC-424E Compatible



Water Management Highlight

Auto ET Adjust

Weather Association: Latest Daily ET: 0.023
 Auto Update: Seven Days Average: 0.023
 ET Usage:
 Update Time 1: : :

TriComm Modem connection to a Davis Instruments Vantage Pro2™ Weather Station provides user account with online ET Data that can be used for daily adjustment of runtimes.

SPECIFICATIONS

Technical

- Internet Access through Web-enabled PC or WAP-enabled Phones or Mobile Devices.
- Individual User Permissioning
- Multiple User Levels
- Password-secured Login
- Controller grouping into "Areas" for shared Season Adjust
- Manual ET Entry & Runtime Adjustment
- Visual connectivity status of each account controller
- Download/Upload communications status bar
- Access to all programming features of TMC-424E
- Manual Station or Manual Program Operation
- Status report of Currently Operating Programs/Stations
- Communications Status and Cellular Signal Strength Display
- Alert & Communications Reports

- Multi-language capability (English, Spanish, French, German, Italian, Portuguese)
- Interactive Maps

Controller Compatibility

TMC-424E Modular Controller

Warranty

- Two year

Electrical

- Transformer input power: 100-240 VAC, 0.8A, 50/60 Hz
- Modem Input Power: 12 VDC, 1.08A
- Hardware Includes:
 - GPRS Modem
 - Plug-in Transformer
 - Antenna
 - Communication cable
- Operating temperature -30°C to 65°C (-22°F-149°F)

Dimensions

- 90mm X63mm X 29mm (WxHxD)
- Weight: 150 g

PRODUCT HIGHLIGHTS



Customizable Alerts

The TriComm System can send real-time e-mail or text-message Alerts to users for alarm conditions (flow, fuse, etc), or standard operations (Station ON, etc).



Status Reports

Controller Status shows currently operating programs and stations with time remaining, as well as any controller alarms.

TRICOMM MODEL LIST

Model	Description
TCOMM-ACTKIT	TriComm™ Wireless Smart Terminal Service Activation Kit One-time Account Activation, GPRS Wireless Smart Terminal Kit with 1 Cellular Modem, 1 120/240VAC - 12VDC Plug, and 12 mos. FREE TriComm Connectivity for use with TMC-424E, TDC, or Davis Vantage Pro2 Weather Station
TCOMM-MODEM	TriComm™ Wireless Smart Terminal 1 TriComm-ready WST65 Cellular Modem, 1 Antenna, 1 Communication Adaptor, 1 Communication Cable, 1 120/240VAC - 12VDC Power Plug, and 12 mos. FREE TriComm Connectivity for use with TMC-424E, TDC, or Davis Vantage Pro II Weather Station
TCMM-MODX	GPRS Wireless Smart Terminal Kit
TCOMM-TDC	TriComm for TDC (Coming Soon) TDC Adaptor Kit and Board for TriComm Modem (modem not included)
TCOMM-WEATHER	TriComm Weather Connect TriComm Weather Connect Cable for use with TriComm Modem and Davis Vantage Pro II Weather Station (modem not included)

Specifying Information — TriComm™ System

Description	Model
TCOMM	XXXXXX
TCOMM—Toro TriComm	ACTKIT – Activation Kit (First Modem in Account) MODEM – Modem Kit (Additional Account Modems) WEATHER – Weather Station Modem and Connection Cable.

SENTINEL® CENTRAL CONTROL



SentinelCentralControl from Toro® is a powerful system that literally “stands guard” over irrigation sites. With the ability to control up to 999 field satellites from one location, users have a water management tool that provides ultimate customizability and reliability.

FEATURES & BENEFITS

Simple To Use

Microsoft® Windows*-based software – daily operations and scheduling are made quick and easy.

Features For Water Management

ET-based watering, flow sensing and optimization, water usage report with historical comparison maximize system efficiency.

Smartphone and Tablet Connectivity

The new Sentinel WMS software package also includes iPhone® and iPad®** connectivity for remote programming and alerts on ALL new systems through NSN® Connect (part of NSN service package).

Multiple Communication Options

Communication options like radio, Wi-Fi, cellular, and Ethernet can be mixed and matched to meet system requirements.

Distributed Programming

Stores irrigation programs in the computer while allowing irrigation control at the satellite level, ensuring the loss of a component does not result in the loss of irrigation across the system.

Toro NSN® Support

All centrals come with a minimum of two years of NSN support – unlimited 24-hour toll-free support with 24/7/365 emergency paging.

*Microsoft and Windows are registered trademarks of Microsoft Corporation in the U.S. and other countries.

**iPhone® and iPad® are registered trademarks of Apple, Inc. in the U.S. and other countries.

Additional Features

- ✓ Flow optimizing to maintain optimum flow and shorten water window
- ✓ Ability to redefine valve sequence without physically changing wire terminations in field satellite
- ✓ Information overview by group and satellite
- ✓ System status indications for individual field satellite
- ✓ On-line help screens
- ✓ Map-based feedback on system status
- ✓ Standard internet connection allows for remote access to central software via NSN® Connect (part of NSN service package)



Rain
Sensor
Compatible



Remote
Ready

SPECIFICATIONS

Electrical

- Control up to 999 field satellites
- Group controllers into "systems" for system-wide adjustments:
 - Rain Days
 - Percent Adjust
 - ET-Adjustment from shared weather source
- Field changes to controller programs can be uploaded to computer
- Support for the System Administration
 - Set system, program and satellite descriptions
 - Map valve positions on site maps
 - Mark special dates on on-screen calendar
- Alarm reporting of any system component

failure, including communications, over/under-flow conditions, electrical problems or power failure

- Extensive reporting features:
 - Run time reports
 - Water usage
 - Alarms
 - Logging of system changes

Warranty

- Two year extendable by continuous NSN subscription



EPA WaterSense approved when used with a Precision™ ET or on site weather station

PRODUCT HIGHLIGHTS



Water Savings – ET-based (multiple weather station options)

Effective ET-based system management can lead to water savings of 25% to 30% per year. As an additional source of savings, pipeline breaks, malfunctioning valves, and missing heads are automatically detected and shut down, preventing excessive water loss.



Distributed Intelligence

Each Sentinel® controller is a fully intelligent unit with program data stored at both the field satellite and within the central computer. In the event a computer or master controller goes off line, there will be no loss of irrigation. True two-way communication allows programming changes to occur at the on-site field controller and uploaded to the central computer. Protection from unauthorized changes is ensured as the controller program can be easily compared to the program saved in the central computer.

Specifying Information—Sentinel Central Control

Codes available in EMEA Region on request

NATIONAL SUPPORT NETWORK (NSN®)



Isn't it nice to know someone's got you covered? Available day or night, you can count on the Toro National Support Network (NSN®) team for total operational confidence.

SPECIFICATIONS

Support for the Sentinel® Central Control

- Every Sentinel central package comes standard with 2-years NSN support
- Unlimited 24-hour toll-free support with 24/7/365 emergency paging
- Technical assistance by email with next business day response
- Remote PC assistance where connectivity is available
- Support of Microsoft® Windows operating system software when purchased from NSN
- NSN lab for field issue duplication and diagnostics
- Technical bulletins
- Remote data storage for duration of subscription period
- Extended warranty on central hardware components with continuous subscription
- User training both hardware and software
- For more information on products, services or training, contact:

Toro NSN
P.O. Box 3339,
Abilene, TX 79604

Phone: 888-676-8676
Website: toronsn.com

FEATURES & BENEFITS



24-Hour, Seven-Day, 365 Support

Worldwide, Toro NSN is always available to answer your questions, troubleshoot your system and solve your problems. And if needed, our 24-hour central computer and component replacement service ensures minimal disruption to the operation of your irrigation system (U.S.).

Toro Product Training — In-Person and Online

Classroom instruction is available at regional locations and at the NSN Training Center—where classes feature hands-on computer training and the operation of Toro hardware. NSN's new internet-based Training In Ten™ features critical instruction that can be learned in ten minutes or less and quickly applied right on-the-job!

Note: NSN Features vary based on the Sentinel product offering purchased. Contact Toro Sales for details.

The Confidence of Working with the Best in the Business

Toro NSN is a Microsoft®* Certified Partner. Our support technicians are licensed irrigators. NSN has a diagnostic lab on-site for each irrigation platform, all field hardware, plus ancillary products. The lab is used to duplicate field issues and investigate causes and solutions as part of Toro's commitment to continuous improvement. NSN is dedicated to irrigation—we know your business and expectations.

New System Support, Flexible Options to Renew

Every new Sentinel offering includes Toro NSN support. To protect your Toro investment long-term, choose a renewal option that gives you exactly what you need for continued reliable, cost-effective support and extended warranty, including equipment upgrades to keep your technology current and powerful.

*Microsoft and Windows are registered trademarks of Microsoft Corporation in the U.S. and other countries.

Specifying Information—NSN/Sentinel Support Extensions

SSE-X-X	
Description	Optional
SSE	-X-X
SSE—Toro NSN Support for Sentinel Subscription Extensions*	T-1—1-year Extension for SGIS-0-1 or SGIS-1-T T-3—3-year Extension for SGIS-0-1 or SGIS-1-T C-1—1-year Extension for SGIS-1-0 (with computer warranty) C-3—3-year Extension for SGIS-1-0 (with computer warranty)

*1- and 3-year NSN extensions can be purchased up-front in conjunction with SGIS packages to provide the end-user with an additional one or three years of NSN support. For example, a customer can order the SGIS-1-0 and the SSE-C-3 which would equal five years of NSN support. These extensions are for original purchases only; existing plan renewals are still purchased through Toro NSN.



RESOURCES

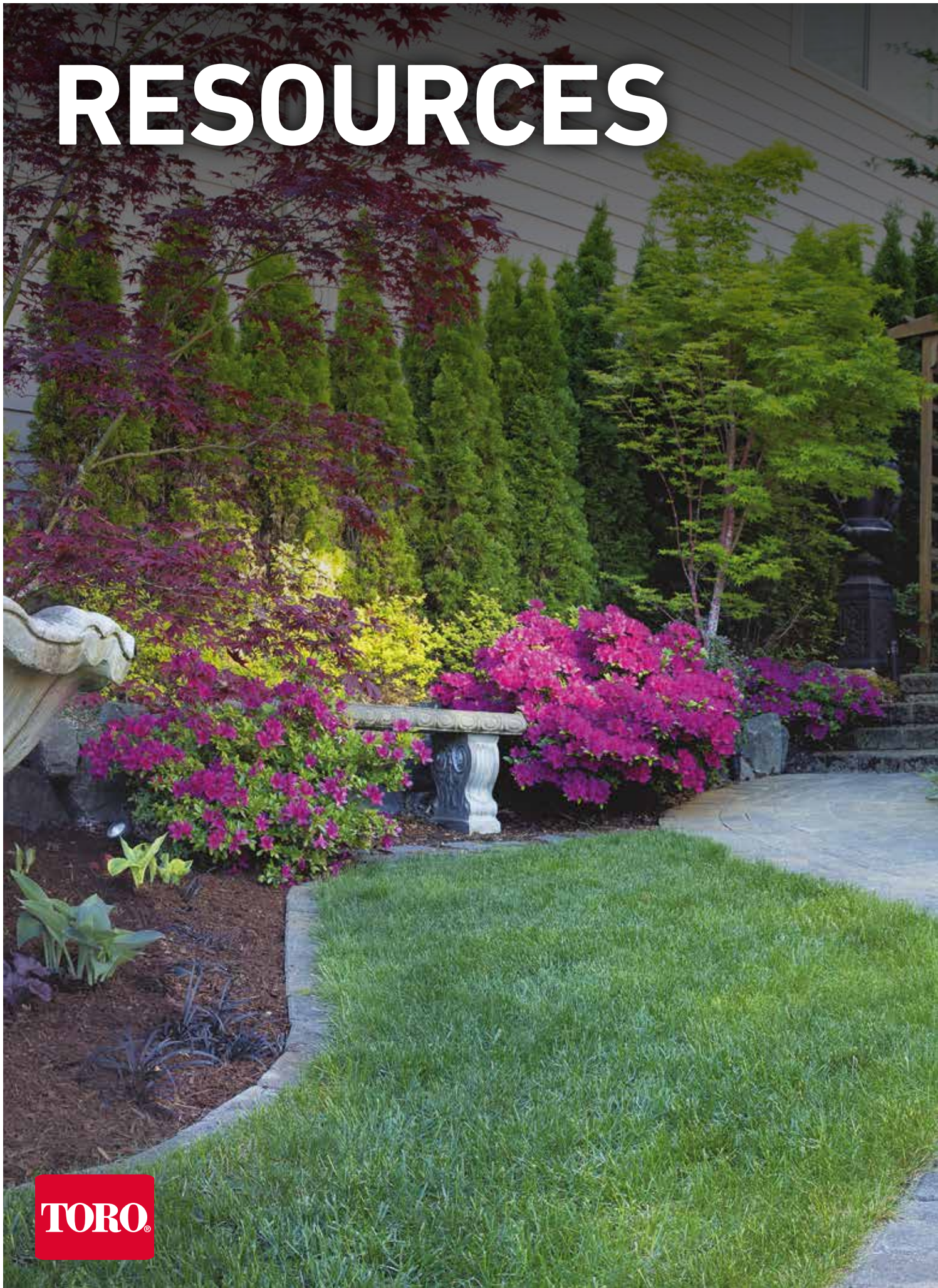



RESOURCES

Pages 165-170

Customer Support	167
Formulas & Conversion Factors	168
Sprinkler Spacing & Winterization	169
Wire Sizing	170

CUSTOMER SUPPORT

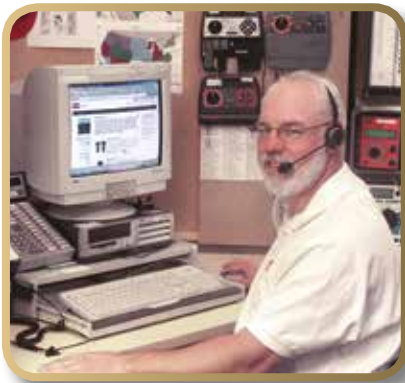

Toro Technical Support

intlirrigation.support@toro.com



Toro NSN®

www.toronsn.com

nsn@toro.com

NSN USA: +1-325-673-8762

NSN Global:

Asia: +61(0) 7 3267 3646

Europe: +32(0) 14 56 29 62

Middle-East Africa: +32(0) 14 56 29 63



www.toro.com

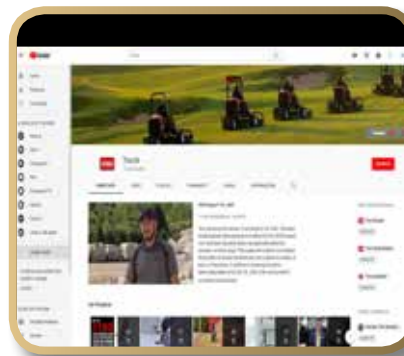

youtube.com/toro



www.toro.com/tempus



Toro Advantage App

FORMULAS AND CONVERSION FACTORS

PRECIPITATION RATES

U.S. (SPACING IN FEET)	METRIC (SPACING IN METERS)
Equilateral Triangular Spacing	
P.R. = $\frac{\text{GPM of 360} \times 96.25}{(\text{in/hr}) (\text{Head Spacing})^2 \times .866}$	P.R. = $\frac{\text{m}^3/\text{hr of 360} \times 1000}{(\text{mm/hr}) (\text{Head Spacing})^2 \times .866}$
Square/Rectangular Spacing	
P.R. = $\frac{\text{GPM of 360} \times 96.25}{(\text{in/hr}) \text{Head Spacing} \times \text{Row Spacing}}$	P.R. = $\frac{\text{m}^3/\text{hr of 360} \times 1000}{(\text{mm/hr}) \text{Head Spacing} \times \text{Row Spacing}}$
Square/Rectangular Spacing for Specific Arc	
P.R. = $\frac{34650 \times \text{GPM (for any arc)}}{(\text{in/hr}) \text{Degrees of Arc} \times \text{Head Spacing} \times \text{Row Spacing}}$	P.R. = $\frac{\text{m}^3/\text{hr (for any arc)} \times 1000}{(\text{mm/hr}) \text{Degrees of Arc} \times \text{Head Spacing} \times \text{Row Spacing}}$
HORSEPOWER	
H.P. = $\frac{\text{GPM} \times \text{Ft of Head}}{3,960 \times \text{Pump Efficiency (expressed as a decimal)}}$	H.P. = $\frac{\text{LPM} \times \text{Meters of Head}}{3,433 \times \text{Pump Efficiency (expressed as a decimal)}}$
STATION RUN TIME	
S.R.T. = $\frac{\text{Total Weekly Req'd (inch/wk)} \times 60 (\text{min/hr})}{(\text{min/wk}) \text{Precipitation Rate (in/hr)}}$	S.R.T. = $\frac{\text{Total Weekly Req'd (mm/wk)} \times 60 (\text{min/hr})}{(\text{min/wk}) \text{Precipitation Rate (mm/hr)}}$
PIPE VELOCITY	
V = $\frac{0.4085 \times \text{Flow (GPM)}}{(\text{ft/sec}) (\text{Inside Pipe Diameter in Inches})^2}$	V = $\frac{1273.24 \times \text{Flow (l/sec)}}{(\text{m/sec}) (\text{Inside Pipe Diameter in Millimeters})^2}$
SLOPE	
S = $\frac{\text{Rise (Measure of Length)}}{\text{Run (Measure of Length)}}$	

TO CONVERT	FROM	TO	MULTIPLY BY
Area	acres	feet ²	43,560
	acres	meters ²	4046.8
	meters ²	feet ²	10.764
	feet ²	inches ²	144
	inches ²	centimeters ²	6.452
	hectares	meters ²	10,000
	hectares	acres	2.471
Power	kilowatts	horsepower	1.3410
Flow	feet ³ /minutes	meters ³ /second	0.00047
	feet ³ /second	meters ³ /second	0.02832
	yards ³ /minute	meters ³ /second	0.01274
	gallons/minute	meters ³ /hour	0.22716
	gallons/minute	liters/minute	3.7854
	gallons/minute	liters/second	0.06309
	gallons/minute	liters/minute	16.645
	gallons/minute	liters/second	0.2774
	meters ³ /hour	liters/second	60
	meters ³ /hour	liters/minute	
Length	feet	inches	12
	inches	centimeters	2.540
	feet	meters	0.30481
	kilometers	miles	0.6214
	miles	feet	5,280
	miles	meters	1609.34
	millimeters	inch	0.03937

TO CONVERT	FROM	TO	MULTIPLY BY
Pressure	psi	kilopascals	6.89476
	psi	bars	.06895
	bars	kilopascals	100
	psi	feet of head	2.31
Velocity	feet/second	meters/second	.3048
Volume	feet ³	gallons	7.481
	feet ³	liters	28.32
	meters ³	feet ³	35.31
	meters ³	yard ³	1.3087
	yards ³	feet ³	27
	yards ³	gallons	202
	acres/feet	feet ³	43,560
	gallons	meters ³	.003785
	gallons	liters	3.785
imperial gallons	gallons	1.833	

CONDUCTOR SIZE-AWG/METRIC

AWG Size	Area (mm ²)	Nearest Metric Size
18	0,82	1,0
16	1,31	1,5
14	2,08	2,5
12	3,31	4,0
10	5,26	6,0
8	8,36	10,0
6	13,29	16,0
4	21,14	25,0

SPRINKLER SPACING & WINTERIZATION SPECIFICATIONS

The Toro Company does not recommend designing for 0 mph wind conditions. Design in consideration of the worst wind conditions.

PRECIPITATION RATE FORMULAS (MM/HR)

Square-spaced sprinklers in pattern:

$$\frac{\text{m}^3/\text{hr of full circle} \times 1000}{(\text{Spacing between sprinklers})^2}$$

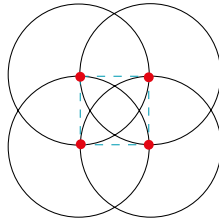

Triangular-spaced sprinklers in pattern:

$$\frac{\text{m}^3/\text{hr of full circle} \times 1000}{(\text{Spacing between sprinklers})^2 \times 0.866}$$

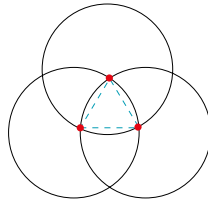

Single row:

$$\frac{\text{m}^3/\text{hr of full circle} \times 1000}{(\text{Spacing}) (\text{Scallop})}$$

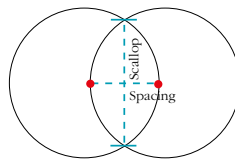

Area and flow:

$$\frac{\text{Total m}^3/\text{hr of full circle} \times 1000}{\text{Total irrigated square feet of zone}}$$

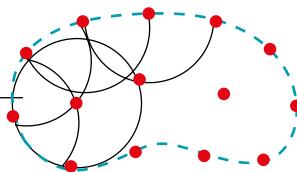

WINTERIZATION SPECIFICATIONS

In freezing climates, sprinklers and valves should be properly winterized to prevent freeze-related damage.

MAXIMUM PRECIPITATION RATES (METRIC)

MAXIMUM PRECIPITATION RATES: MILLIMETERS PER HOUR								
Soil Texture	0 to 5% slope		5 to 8% slope		8 to 12% slope		12% + slope	
	Cover	Bare	Cover	Bare	Cover	Bare	Cover	Bare
Coarse sandy soils	50,8	50,8	50,8	38,1	38,1	25,4	25,4	12,7
Coarse sandy soils over compact subsoils	44,5	38,1	31,8	25,4	25,4	19,1	19,1	10,2
Light sandy loams uniform	44,5	25,4	31,8	20,3	25,4	15,2	19,1	10,2
Light sandy loams over compact subsoils	31,8	19,8	25,4	12,7	19,1	10,2	12,7	7,6
Uniform silt loams	25,4	12,7	20,3	10,2	15,2	7,6	10,2	5,1
Silt loams over compact subsoil	15,2	7,6	12,7	6,4	10,2	3,8	7,6	2,5
Heavy clay or clay loam	5,1	3,8	3,8	2,5	3,0	2,0	2,5	1,5

The maximum PR values listed above are as suggested by the United States Department of Agriculture. The values are average and may vary with respect to actual soil condition and condition of ground cover

WIRE SIZING

METHOD OF WIRE SIZING FOR ELECTRICAL COMPONENTS OF AN AUTOMATIC IRRIGATION SYSTEM

Data Needed

- Maximum current draw of the electrical unit (valve or controller) in amperes (I)
- Distance in meter (one way) to the electrical unit (F)
- The allowable voltage drop in the wire without affecting functions of the electrical unit (Vd)

Steps

1. Calculate the maximum allowable wire resistance per 300 meters with the following formula:

$$R = \frac{152 \times Vd}{F \times I}$$

where R = allowable wire resistance per 305 meters.

2. Select the wire size from Chart #2 which has a resistance less than that calculated in the above formula.

Example: A valve with a minimum operating voltage of 20 volts and inrush current of 0.30 amps is to be located 815m from a controller. The controller minimum output voltage is 24 Vac.

The allowable voltage drop

$$(Vd) = 24 - 20 = 4 \text{ volts}$$

The distance to valve (F) = 815m

The current draw (I) = 0.3 amps

$$R = \frac{152 \times 4}{815 \times 0.3} = 2.45 \text{ ohm/300m}$$

From Chart #2 we find that #14 AWG wire has slightly too much resistance. Therefore, choose #12 AWG copper wire.

The accompanying charts are useful for quick and easy selection of wire sizes for valves with standard and optional solenoids. Chart #3 is set up to provide maximum wire runs given a standard 24 Vac valve with a minimum operating voltage of 20 volts and a controller output of 24 Vac Chart #4 is a multiplier factor for determining maximum wire runs for other controller output voltages and optional solenoids.

Example: Determine maximum wire run to a valve with model 24 Vac-D solenoid and controller output voltage of 26 volts and #14 control and ground wire.

From Chart #3 we find a length of 789m with #14 ground and control wire. From Chart #4 the multiplier factor at 26 Vac controller output with a model 24 Vac-D solenoid is 4.33. Therefore, the maximum wire distance to the valve is: 4.33 x 789m = 3416m.

* This assumes control wire and ground wire are the same size.

MINIMUM OPERATING VOLTAGES AT VARIOUS STATIC PRESSURES (STANDARD 24 VAC SOLENOID)

CHART 1
Minimum Solenoid Operating Voltage Under Various Line Pressure

Line Pressure	Voltage (Internal Bleed Configurations)	Voltage (External Bleed Configurations)
13,8 Bar	21.1	
12,1 Bar	20.2	
10,3 Bar	19.1	20.0
8,6 Bar	18.2	19.1
6,9 Bar	17.1	18.2
5,2 Bar	16.1	17.3
3,4 Bar	16.0	16.4

CHART 2
Copper Wire Resistance of Various Sizes

Sizes AWG	Resistance at 20°C Ohms per 300m.
4	0.25
6	0.40
8	0.64
10	1.02
12	1.62
14	2.57
16	4.10
18	6.51

CHART 3
Maximum One-way Distance (ft.) Between Controller and Valve (standard 24 Vac solenoid) †

Valve Wire Sizing							
Ground Wire	Control Wire						
	18 AWG (1,0mm ²)	16 AWG (1,5mm ²)	14 AWG (2,5mm ²)	12 AWG (4,0mm ²)	10 AWG (6,0mm ²)	8 AWG (10,0mm ²)	6 AWG (16,0mm ²)
18 AWG (1,0mm ²)	311	384	448	500	539	567	588
16 AWG (1,5mm ²)	384	497	610	710	796	856	902
14 AWG (2,5mm ²)	448	610	789	969	1131	1265	1366
12 AWG (4,0mm ²)	500	710	969	1256	1539	1798	2009
10 AWG (6,0mm ²)	539	796	1131	1539	1993	2448	2859
8 AWG (10,0mm ²)	567	856	1265	1798	2448	3170	3892
6 AWG (16,0mm ²)	588	902	1366	2009	2859	3892	5041

† Solenoid Model: 24 V ac Pressure: 150 psi Voltage Drop: 4 V Min. Op. Voltage: 20 V Amperage (peak): 0.3A

MULTIPLIER FACTOR FOR VARIOUS CONTROLLER OUTPUT VOLTAGES AND OPTIONAL LOW-VOLTAGE SOLENOIDS

CHART 4

Controller Output Voltage	24-Volt Solenoids		
	24 Vac	24 Vac-D	24 Vdc
28	2.00	5.77	5.45
27	1.75	5.05	4.77
26	1.50	4.33	4.09
25	1.25	3.61	3.41
24	1.00	2.88	2.73
23	.75	2.16	2.05
22	.50	1.44	1.36

CHART 5

Controller Output Voltage	12-Volt Solenoids		
	12 Vac	12 Vac-D	12 Vdc
16	.58	2.50	1.96
15	.50	2.08	1.63
14	.41	1.67	1.30
13	.33	1.25	.98
12	.25	.83	.65
11	.17	.42	.33



Irrigation

5825 JASMINE STREET

**Toro is always there to help you care for your landscapes the way you want,
when you want, better than anyone else.**



www.toro.com

Worldwide Headquarters
The Toro Company
8111 Lyndale Ave. So.
Bloomington, MN 55420 U.S.A.
Phone: (1) 952 888 8801
Fax: (1) 952 887 8258

©2019 The Toro Company
All Rights Reserved

GB 200-8895

Products depicted in this literature are for demonstration purposes only. Actual products offered for sale may vary in use, design, required attachments and safety features.

We reserve the right to improve our products and make changes in specifications, design and standard equipment without notice and without incurring obligation. See your dealer for details on all our warranties.



facebook.com/toro.yard
twitter.com/TheToroCompany
youtube.com/ToroCompanyEurope