



TransPro® 80/200

WALK GREENSMOWER TRAILERS

FEATURES

TransPro 200

- Safely transport 1 or 2 walk greens mowers
- Rail ramp module simplifies operation and reduces loading time by up to 50% – no need to mount mower transport wheels
- Adjustable roller pockets allow for configuration of fixed units, flex units, with or without groomers
- Combination of roller pocket, rubber mats and wheel/donut retainer securely retain mower(s) in place helping keep mower adjustments intact. Once the ramp or rails are raised – units are locked in place
- Open trailer design allows for easy washdown of the mower without unloading
- Single configuration for either 18" (45.7cm) or 21" (53.3cm) wide units
- Hitch pin release is incorporated into convenient lift handle for trailer hitch. 2.5" (6.35cm) adjustable hitch height for level trailering and loading

TransPro 80

- Safely transport 1 walk greens mower
- Rail ramp simplifies operation and reduces loading time by up to 50% – no need to mount mower transport wheels
- Large trailer tires to cushion ride and help protect mower during transport
- Rubber mat protects greens mower front rollers during transport, helping keep mower adjustments intact
- Open design allows servicing and washdown while mower is on the trailer
- Quick-lock device secures mower to the trailer for safe transport

Safely and easily transport one or two walk greensmowers.

Toro® TransPro® trailers safely and easily transport walk greens mowers to and from the mowing area. The unique design protects your mower investment and keeps adjustments intact. The TransPro 80 accommodates a single Greensmaster® with a Flat Ramp or Rail Ramp Kit. For additional time and productivity gains, transport two mowers (excluding the Greensmaster 1600 and 1026) with the TransPro 200.





TransPro® 80 / 200*

Safely and easily transports one or two walk greensmowers to and from the mowing area.

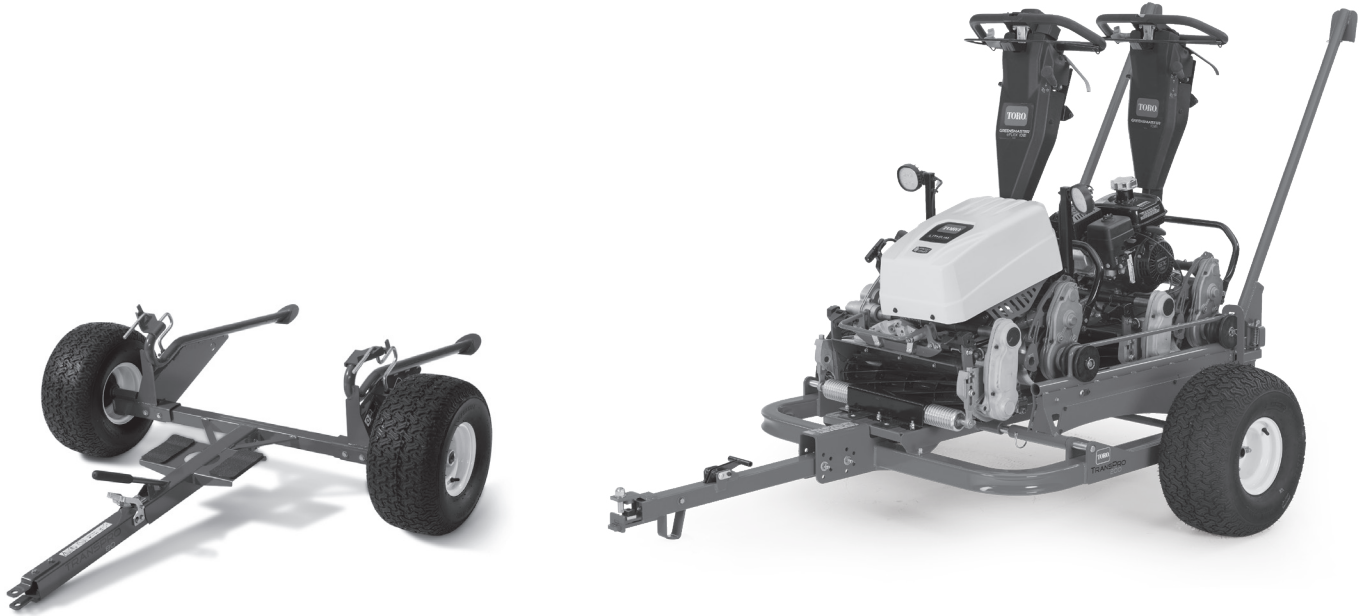

	TRANSPRO 80, MODEL 04235	TRANSPRO 200, MODEL 04239
LOAD CAPACITY	400 lbs. (181.6 kg) including weight of trailer	1,150 lbs. (522 kg) including weight of trailer
SUSPENSION	Large low pressure tires (20 x 10-8)	
TRANSPORT SPEED	Maximum of 15 mph (24 km/h)	
RAMP	Textured split ramp design with detented wheel retainers	Textured split ramp design with spring-loaded ramp retainers for storage during transport operation
RAIL	Textured loading rails for use in conjunction with smaller bogey (donut) wheels in place of transport tires.	
HITCH	Pin release is incorporated into lift handle.	
TOWING	Designed to tow behind a utility vehicle with tongue height 7"-13" (18-33 cm); maximum tongue load 55 lbs. (25 kg)	
RETENTION METHOD	Adjustable front roller pockets and wheel/donut retainer positively secure mower for transport	
FINISH	Rust/corrosion-resistant paint	
AXLES	Heavy-duty stub. Maintenance-free sealed bearings.	
DIMENSIONS	Height: 19" (48.3 cm) Width: 62" (157.5 cm) Length: 81" (205.7 cm)	Height: 61" (154.9 cm) Width: 68" (172.7 cm) Length: 108" (274 cm)
TRAILER WEIGHT	Ramp configuration: 147 lbs (67 kg) Rail configuration: 136 lbs (62 kg)	Ramp configuration: 389 lbs (176kg) Rail configuration: 329 lbs (149 kg)
	Easily adjustable to fit all Toro walk greensmowers (optional axle kit may be required)	Easily adjustable to fit all 18" and 21" Toro walk greensmowers. (not recommended for Greensmaster® 1600 or 1026)

TRANSPRO 80 ACCESSORIES	TRANSPRO 200 ACCESSORIES
04236 Flat Ramp Kit	04219 Wheel Loading Kit
04237 Rail Ramp Kit	04229 Rail Loading Kit
107-8188 Hitch Kit	144-5668 Axle kit - Greensmaster Flex18/21
136-7287 Extended Axle for Rail Ramp Using 04648 Groomer for Flex18XX/21XX units	144-5664 Axle kit - Greensmaster Flex 18XX/21XX
139-6478 Extended Axle Shaft - 1018/1021/1026 fixed head units with groomer	144-5663 Axle kit - Greensmaster 800/1000 Series
139-2732 Extended Axle Shaft - 1018/1021 Flex head units with groomer	145-0058 - Bogey Wheel
145-0058 - Bogey Wheel	

*Specifications and design subject to change without notice. Products depicted in this literature are for demonstration purposes only. Actual products offered for sale may vary in use, design, required attachments and safety features. Consult your local Toro Distributor.

