



FieldFill™ 660

SYNTHETIC TURF GROOMER

FEATURES

- Superior Incorporation of Infill on Synthetic Turf Fields – *incorporate new infill and groom the field surface all in a single pass*
- Rejuvenate and Decompact Your Turf – *five rotating brushes work to stand up tired turf fibers and lightly decompact infill material helping to make your field look and play like new again*
- Brush Aggressiveness Set By Field Manager – *consistent results from pass to pass with no adjustments needed by operator*
- Efficient Operation – *the 66" (167.6 cm) working width and operational speed of up to 5 mph (8 km/h) provides the productivity you desire*



Incorporate and Smooth Infill & Rejuvenate Synthetic Turf.

The Bullseye FieldFill 660 is designed to quickly work even the heaviest amounts of infill materials into the field surface. It can also be used to lightly decompact existing infill material and rejuvenate and groom an older synthetic turf sports field. The 660 is equipped with five hydraulically-powered and adjustable speed rotating brushes which loosen, decompact, and incorporate infill. The two straight brushes serve to smooth the infill and groom the surface for great results in a single pass. Based on operating speed and working width, this machine is highly-productive – helping to get your job completed quickly.





FieldFill™ 660*

The Bullseye FieldFill 660 is designed to quickly work even the heaviest amounts of infill materials into the field surface. It can also be used to lightly decompact existing infill material and rejuvenate and groom an older synthetic turf sports field. The 660 is equipped with five hydraulically-powered and adjustable speed rotating brushes which loosen, decompact, and incorporate infill. The two straight brushes serve to smooth the infill and groom the surface for great results in a single pass. Based on operating speed and working width, this machine is highly-productive – helping to get your job completed quickly.

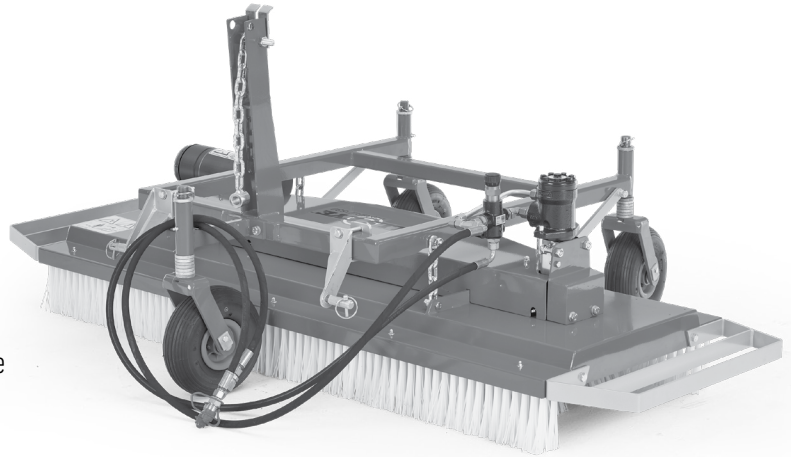

BULLSEYE FIELDFILL 660, MODEL 46423	
WORKING WIDTH	66" (167.6 cm)
TRACTOR REQUIREMENT	10 hp (7.45 Kw) and 441 lbs. (200 kg) lift capacity minimum, category 1, 3-point hitch required
HYDRAULIC CONNECTION	One set of ports with continuous flow
MAXIMUM CAPACITY	145,200 square feet per hour (13360 square meters per hour)
WEIGHT	375 lbs. (170 kg)
DIMENSIONS	Width 81.5" (205.4 cm) Height 33.5" (84.4 cm) Length 51.5" (130.8 cm)
WARRANTY	One-year limited warranty. Refer to the Operator's Manual for further details.

*Specifications and design subject to change without notice. Products depicted in this literature are for demonstration purposes only. Actual products offered for sale may vary in design, required attachments and safety features. Consult your local Toro Distributor.

