

Media Filter Single Chamber : F660IVL

Extension Legs Assembly Instructions

Step 1 – Remove extension legs (2) from the box (1), carefully remove the cardboard and the nylon wrapping (3)

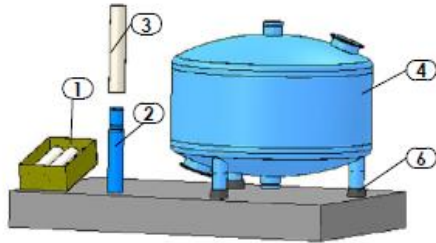

Step 2 – Carefully raise the media filter (4) with ****quilted forklift** or tilt it, and remove the rubber caps (6) from the

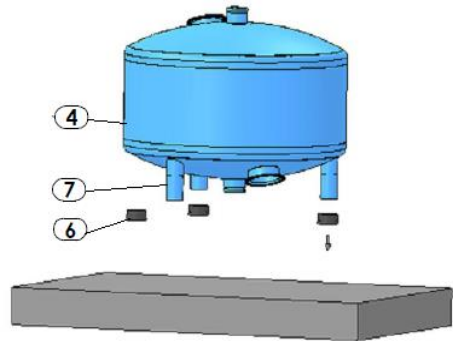

Step 3 – Place the rubber caps (6) on the bottom of the extension legs (2).
***Note:** The caps fit snugly on only one end of the leg.

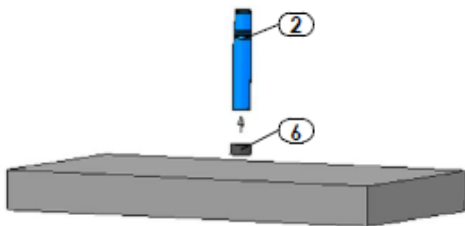

Step 4 – Attach the extension legs (2) to the media filter legs (7) either using a ****quilted forklift** or by tilting

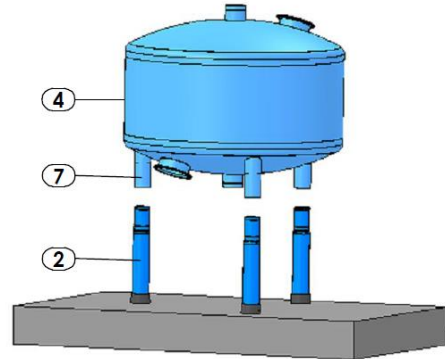

Step 5 – Assembly is now completed.

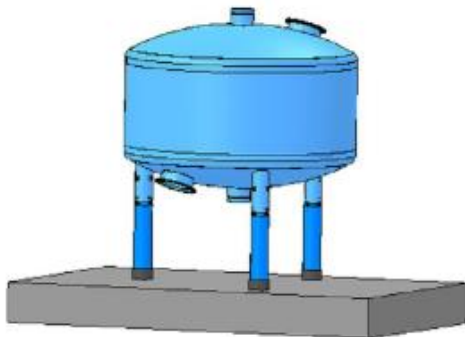

**** “Quilted forklift” – to prevent and avoid Polyester coating damage.**