



POPE

Renegade 26cc Line Trimmer

Model Numbers: 101PLT25FC

101PLT25FCB

Operator's Manual



WARNING

To reduce the risk of injury, the user must read and understand the Operator's Manual. Save this manual.

READ THIS INFORMATION

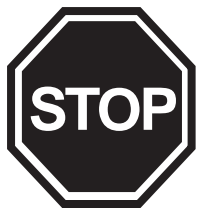

Before you use your new Line Trimmer read this manual carefully to learn how to operate and maintain your product correctly. Reading this manual will help you and others avoid personal injury and damage to the product. Although Pope designs safe state-of-the-art products, you are responsible for using the product properly and safely. You are also responsible for training persons you allow to use the product about safe operation.

Introduction

Thank you for purchasing a Pope® product.

We would like you to be completely satisfied with your new product, so feel free to contact an authorised service dealer for help with service, genuine Pope parts or other information you may require. Or phone the Pope Customer Service Centre for details of your nearest dealer on 1300 134 880.

The Pope warning system in this manual identifies potential hazards and special safety messages that help you and others avoid personal injury, even death. DANGER, WARNING and CAUTION are signal words that identify the level of hazard. However, regardless of the hazard, be extremely careful. Two other words “Important” and “Note” highlight other valuable information.

Signal Word	Explanation
DANGER	Indicates an imminently hazardous situation which, if not avoided, will result in death or serious injury.
WARNING	Indicates a potentially hazardous situation which, if not avoided, could result in death or serious injury.
CAUTION	Indicates a potentially hazardous situation which, if not avoided, could result in death or serious injury.
Important	Advises you of important information or instructions vital to the operation or maintenance of the equipment.
Note	Advises you of additional information concerning the operation or maintenance of the equipment.

Contents

Safety Rules	4
Symbols	5
Specifications	6
Applications	7
Features	7
Unpacking	8
Assembly	9
Attaching the Upper Shaft with Engine to the Lower Bent Shaft Cutting Head	9
Attaching the Front Handle	9
Attaching the Grass Deflector Shield	10
Fitting the Carry Strap	10
Operations	11
Before you Start the Trimmer	11
Mixing the Fuel	11
Filling the Tank	11
Starting the Engine	12
To Start a Cold Engine	12
To Start a Warm Engine	12
Starting a Flooded Engine	12
Operating the Engine	13
To Advance the Cutting Line	14
To Advance the Cutting Line Manually	14
Grass Deflector Line Trimming Cut-Off Blade	14
Maintenance	14
Emissions Maintenance Schedule	14
Cleaning the Product	14
Replacing and Cleaning the Air Filter	15
Spark Plug	15
Replacing the Cutting Line	15
To Store the Product Long Term	16
Troubleshooting	17
Warranty	18

Safety Rules









WARNING

Read and understand all instructions. Failure to follow all instructions may result in serious personal injury as well as damage to product.

- **Physical Conditions of the Operator.** Do not operate this product when tired, ill or under the influence of alcohol, drugs or medication.
- **Clothing Requirements.** Always wear long heavy pants, boots and gloves. Do not wear loose clothing, jewellery, short pants, sandals or go barefoot. Secure hair so that it is above shoulder level to avoid entanglement in moving parts.
- **Protective Accessories Requirements.** Wear safety eye protection when operating this product. Wear hearing protection during extended periods of operation.
- **Condition of Product before Use.** Inspect the product before each use. Replace damaged parts. Check for fuel leaks. Make sure all fasteners are in place and secure. Replace cutting attachment parts that are cracked, chipped or damaged in any way. Make sure the cutting attachment is properly installed and securely fastened. Be sure the cutting attachment guard is properly installed and in the position recommended by the manufacturer. Use only flexible, non-metallic line recommended by the manufacturer. For example, never use wire or wire rope, which can break off and become a dangerous projectile.
- **Proper Stance.** Keep firm footings and balance. Do not overreach. Keep the cutting attachment below waist level. Keep all parts of your body away from the rotating cutting attachment and hot surfaces.
- **Exhaust Gases.** Never start or run the product inside a closed room or building; breathing exhaust fumes can cause illness or death.
- **Fuelling.** Mix and pour fuel outdoors where there are no sparks or flames. Slowly remove the fuel cap only after stopping the engine. Do not smoke while fuelling or mixing fuel. Wipe spilled fuel from the product. Move at least 9m from the fuelling source and site before starting the engine.
- **Work Area.** Clear the area to be cut before each use. Remove all objects such as rocks, broken glass, nails, wire or string that can be thrown or become entangled in the cutting attachment. Clear the area of bystanders, pets and children. At a minimum, keep all bystanders, pets and children outside a 15m radius. Because there still may be a risk to bystanders from thrown objects, bystanders should be encouraged to wear eye protection. If you are approached while operating the product, stop the engine or for those products equipped with a clutch be sure the cutting attachment has stopped moving.
- **Dangerous Environments.** To avoid falling, do not use the product in damp or wet locations.
- **Controlling the Product.** During carburettor adjustments the cutting attachment may spin. Therefore you should wear protective equipment and observe all safety instructions when adjusting the carburettor. Be sure the cutting head has stopped rotating before setting down or adjusting the product. Maintain proper control until the cutting head has completed stopped rotating.
- **Use the Right Product.** Use the product for the intended purposes only.

Symbols

The following symbols are located on the product. Please study them and learn their meaning. Proper interpretation of these symbols allows you operate the product better and safer.

Symbol	Name	Explanation
	Safety Alert	Indicates danger, warning or caution. Attention is required in order to avoid serious personal injury. May be used in conjunction with other symbols or pictographs.
	Thrown Objects	Thrown objects can cause severe injury. Wear protective clothing and boots.
	Keep Bystanders Away	Keep all bystanders, especially children and pets, at least 15 metres from the operating area.
	No Blade	Do not install any type of blade on Model No. 101PLT25FC. Use only flexible, non-metallic line recommended by the manufacturer.
	Read Operator's Manual	Read the Operator's Manual before starting or operating this product. Failure to follow operating instructions and safety precautions in the Operator's Manual can result in serious injury.
	Eye and Ear Protection	Thrown objects can cause severe eye injury. Wear eye protection when operating this product. Wear hearing protection during extended periods of operation.
	Petrol and Oil	Use unleaded petrol intended for motor vehicle use with an Octane rating of 87 $([R + M] / 2)$ or higher. This product is powered by a 2 cycle engine and requires pre-mixing and 2 cycle oil.

Specifications

Model Numbers: 101PLT25FC
101PLT25FCB

Engine: 26cc Full Crank

Cutting Diameter: 400 mm

Line Size: 2.00 mm

Weight (Dry): 5.1 kg

Fuel Tank Capacity: 0.5 Litres

Fuel Petrol/Oil Mix: 25:1

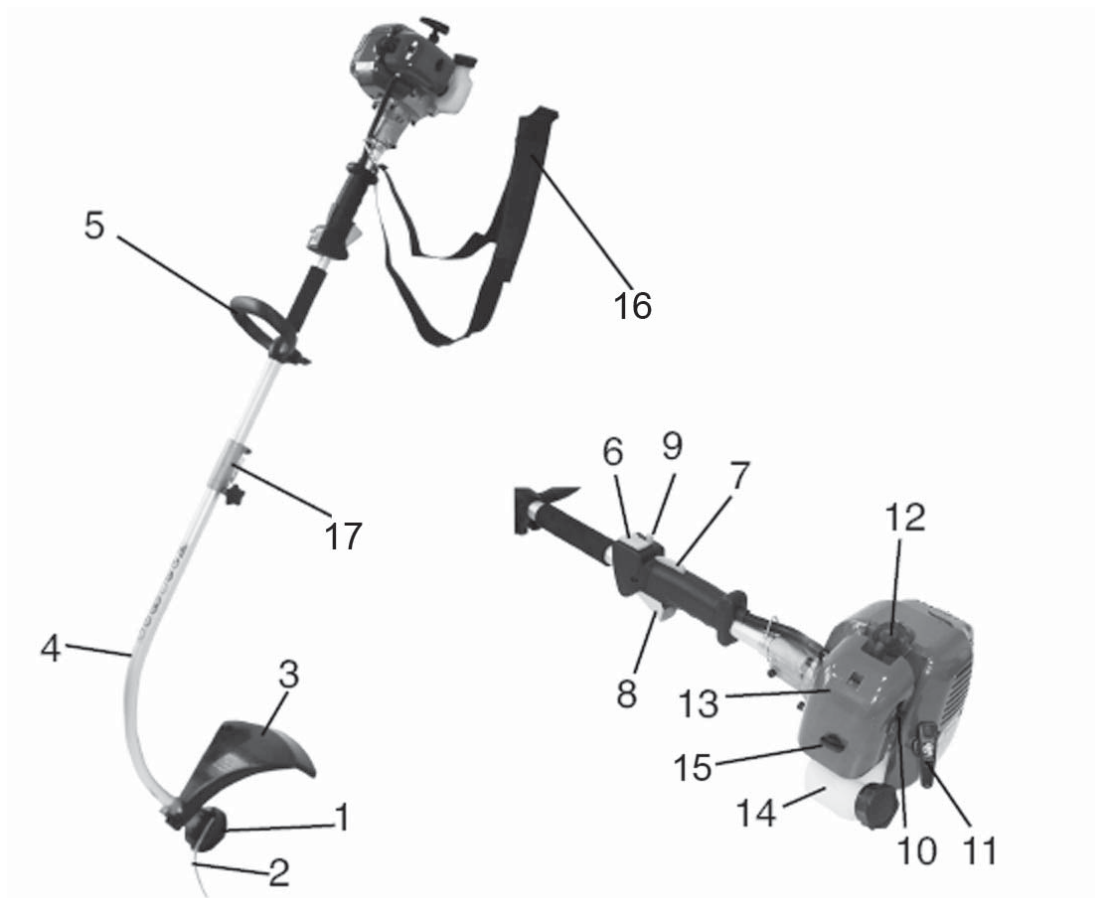

1. Line Trimmer Cutting Head
2. Cutting Line
3. Grass Deflector Shield
4. Lower Bent Shaft
5. Front Handle
6. Engine On/Off Switch
7. Throttle Lever Release
8. Throttle Lever
9. Throttle Lock
10. Choke Lever
11. Starter Cord
12. Spark Plug Boot
13. Air Filter Housing Cover
14. Fuel Tank
15. Primer Bulb
16. Carry Strap
17. Shaft Connection Piece

Applications

Use this product for the following applications:

- Cutting grass, weeds and light undergrowth
- Edging along sideways and driveways
- Do not attempt to use this product as a drive unit for other work tools or tool kits of any kind.

Features



WARNING:

Exercise caution when using the product. Careless actions, for even a fraction of a second, can result in serious personal injury.

Your new product is equipped with the following features:

Engine

The engine is powerful and easy to start. It is effectively counterbalanced, with a full crank which provides less vibration and more durability.

Dual Line

The dual line permits more efficient cutting than a single line.

Grass Deflector

The grass deflector helps protect you from flying debris. The deflector also includes a cutting blade that automatically trims the line to the correct length.

Ergonomic Handle Design

The design of the product provides for easy handling. It is designed for comfort and ease of grasp when operating in different positions and at different angles.



WARNING:

Do not attempt to modify this product or create accessories not recommended for use with this product. Any such alteration or modification is misuse and could result in a hazardous condition leading to serious personal injury and will void your guarantee.

Unpacking

Instructions

- Carefully remove the product from the box
- Inspect the product carefully to make sure no breakage or damage occurred during shipping.
- Do not discard the packing material until you have carefully inspected and satisfactorily operated the product.
- If any parts are damaged or missing, please call 1800 134 880.



WARNING:

If any parts are missing, do not operate the product until the missing parts are replaced. Failure to do so could result in serious personal injury.

Packing List

Renegade 26cc Line Trimmer
Model Numbers: 101PLT25FC
101PLT25FCB

- Upper Shaft
- Lower Bent Shaft
- Grass Deflector Shield
- Carry Strap
- Front Handle
- Operator's Manual
- Tool Kit containing:
 - Spark Plug Wrench, Tube Spanner with Phillips Head Screwdriver attachment (1)
 - Fuel Mixing Container (1)
 - Allen Key (1)

Assembly

Attaching the Upper Shaft with Engine to the Lower Bent Shaft Cutting Head

See Fig. 1, 2 and 3

Follow these steps to attach the two shafts together.

The lower bent shaft connects to the upper shaft with engine by means of a coupler.

1. Loosen the knob on the coupler of the upper shaft (Fig. 1, Item 1).
2. Press the lever catch (Fig. 1, Item 2) and insert lower bent shaft into upper shaft with engine.
3. Ensure that the inner drive cable is seated by rotating cutting spool.

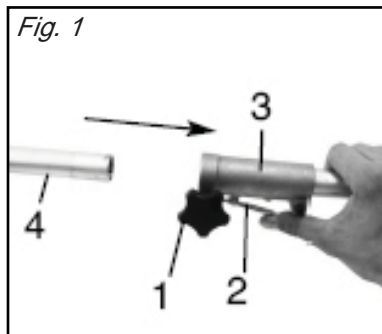

4. Ensure that the lug (Fig. 2, Item 6) is located in the hold in the lower shaft.

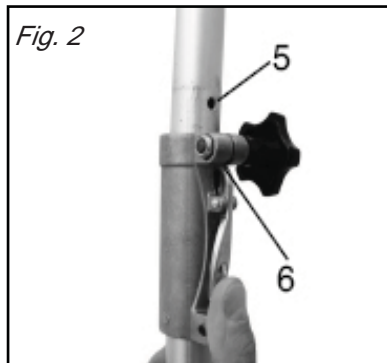

5. Retighten knob (Fig. 3)
6. To dismantle, use the steps above in reverse order.

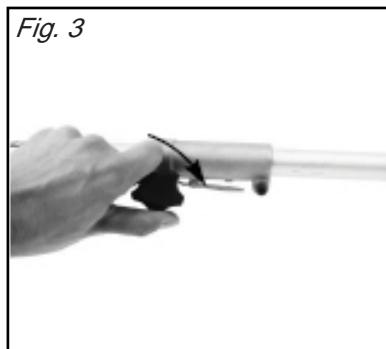

Attaching the Front Handle

See Fig. 4, 5 and 6

Follow these steps to attach the front handle.

1. Loosen the wing nut on the fastening screw on the handle (Fig. 4, Item 1).
2. Remove the wing nut and the washer from the handle (Fig. 4, Item 2).
3. Remove the fastening screw from the handle (Fig. 4, Item 3).

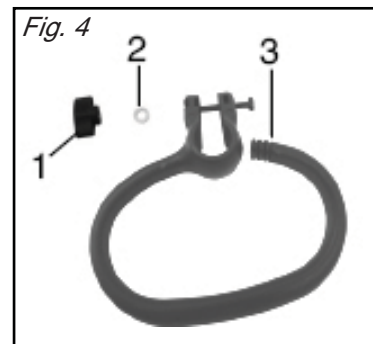

4. Push the front handle onto the upper shaft (Fig. 5).

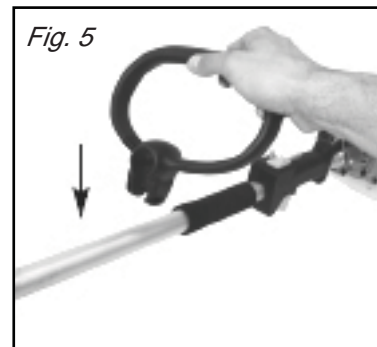

5. Replace the fastening screw on the handle.
6. Replace the wing nut and the washer on the handle.
7. Tighten the wing nut (Fig. 6).

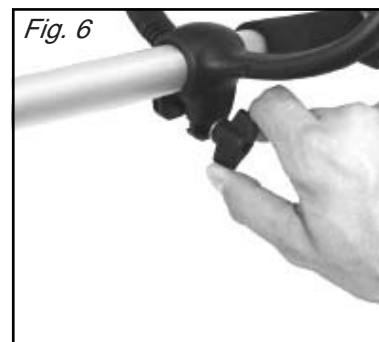

Assembly

Attaching the Grass Deflector Shield

See Figs. 7, 8 and 9

Follow these steps to attach the Grass Deflector Shield.

1. Using the Allen Key provided, loosen the fastening screw on the guard hood (Fig 7, Item 1) and remove.
- 2.

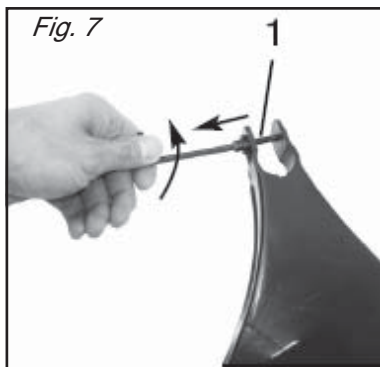

3. Attach the grass shield to the base of the lower shaft (Fig. 8).

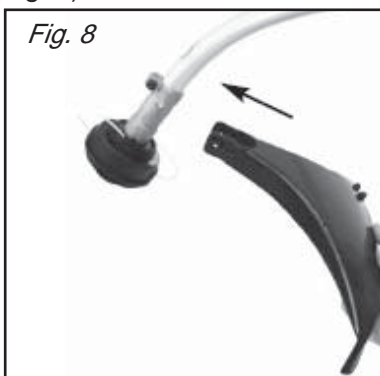

4. Screw the grass shield tightly in position with fastening screw (Fig. 9).

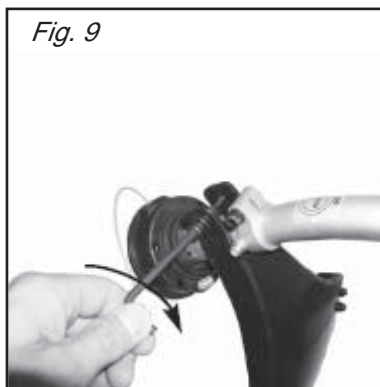

Fitting the Carry Strap

See Fig. 10

Follow these steps to fit the carry strap.

The carry strap is intended to help you work safely and ergonomically with your trimmer.

1. Hook the carry strap into the fastening eyelet (A).
2. Ensure the hook is securely fastened at the right operating height before attempting any work.

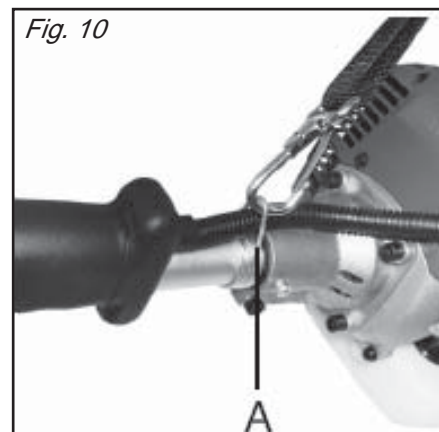

WARNING:

Check that all moving parts operate smoothly before you start your trimmer. **Check** that all screws are securely fastened.

Operation

Before you start the Trimmer

Setting your cutting height

1. Slip the carry strap over the left shoulder.
2. Set the length of the carry strap in such a way that the cutting head runs parallel to the ground. In order to establish the optimum length of the carry strap you should make a few swinging movements without starting the engine.



WARNING:

Always use the carry strap when using the trimmer. Attach the strap as soon as you have started the engine and the engine is running in idle.

Switch off the engine before you take off the carry strap.

Follow these steps to mix the fuel.

1. Use an approved mixing container for mixing fuel.
2. Mix the 2 stroke engine oil with unleaded petrol in the container provided at the rate of 25 parts petrol to 1 part oil.
3. Mix the fuel thoroughly and also each time before re-fuelling.
4. Mix in small quantities. Do not mix more fuel than you expect to use within a 30 day period.
5. Store fuel only in a clean, safe, approved container for petrol.



Filling the Tank

Follow these steps to fill the tank



WARNING:

Always stop the engine before filling the tank. Never add fuel to a machine with a running or hot engine. Move at least 9 m away from the re-fuelling site before starting the engine. Do not smoke while filling the tank. Do not add fuel to the tank close to an open fire or sparks. Never add fuel to the tank in a closed or non-ventilated area.

1. Clean the surface around the fuel tank to prevent contamination.
2. Loosen the fuel cap slowly and rest the cap on a clean surface.
3. Pour the fuel mixture carefully into the tank.
4. Clean and inspect the gasket. **Note:** Replace the fuel cap if the gasket is damaged.
5. Install the fuel cap and hand tighten.



WARNING:

Check for fuel leaks. If you find any leaks, correct the problem before using the product.

6. Wipe spilled fuel from the product.
7. Move at least 9 metres away from tank re-fuelling site before starting the product.

Note: It is normal for the engine to emit smoke during first use.

Mixing the Fuel



DANGER:

Petrol is extremely flammable and explosive. A fire or explosion from petrol will burn you and others.

This product is powered by a two stroke engine and requires pre-mixing petrol and 2 stroke oil. The oil should be 25:1. Never mix petrol and oil directly in the engine tank.

Use unleaded petrol intended for motor vehicle use with an Octane rating of 87 ([R + M] /2) or higher. Purchase fuel from a reputable fuel supplier.

Use an approved mixing container to mix the petrol and oil in the correct quantities.

Petrol	Oil
1 Litre	40 mL
2 Litres	80 mL
3 Litres	120 mL
4 Litres	160 mL

Mix only enough for your immediate needs. Fuel should not be stored for more than 30 days.

Operation - *continued*

Starting the Engine

Starting the product depends on whether the engine is cold or warm.



WARNING:

The recoil starter can be damaged by abuse. Never pull the starter cord to its full length. Always engage the starter before cranking the engine. Always rewind the starter cord slowly.



CAUTION:

Operating the machine with loose, missing or damaged components could allow the engine to over-speed, possibly causing serious engine damage. Inspect the entire machine for damage, loose or missing components or fastenings and repair as necessary.



WARNING:

A cutting blade on the underside of the grass shield automatically cuts the cutting line to the optimum length. This blade is covered by a transport cover. Remove this cover before you start working and replace it after you have finished using the trimmer.

To Start a Cold Engine

Follow these steps to start a cold engine:

1. Lay the product on a flat bare surface.
2. Set the choke lever to the full choke position.
3. Switch the ON/OFF switch to "I".
4. Push the primer bulb approximately 10 times until fuel comes into the primer pump.
5. Using the throttle lock, set the throttle open.
6. To engage starter, hold the machine handle firmly with your right hand, pull the starter cord slowly until you feel resistance.
7. Start the engine by pulling the starter cord upward rapidly. If necessary, repeat two or three times until the engine starts.
8. Let it run for 10 seconds before moving the choke lever fully open.

9. Since the throttle has been secured in the open position the cutting head will start to rotate. To release the throttle simply operate the throttle and then by releasing it the throttle will return to idle.
10. Run the engine at idle speed until operating temperature is reached (2-3 minutes).
11. The machine should now be ready for use.

IMPORTANT: For maximum line trimmer performance and operating life, allow engine to warm before use.

To Start a Warm Engine

Follow these steps to start a warm engine:

1. Lay the product on a flat, bare surface.
2. Switch the ON/OFF switch to "I".
3. Secure the throttle lever the same way as starting a cold engine.
4. Pull the starter cord until you find resistance (engaging the starter cog) then pull sharply on the starter.

Note:

If the product does not start, repeat the previous steps. Check that the fuel tank has sufficient fuel for the engine to start or that the engine cooled sufficiently to allow for a "cold start".

Starting a Flooded Engine

1. Disconnect the spark plug boot and use the spark plug wrench supplied to remove the plug in a counter-clockwise direction.
2. If the spark plug is fouled or is soaked with fuel, clean or replace the plug as required.
3. Turn the product so that the spark plug hole is aimed at the ground.
4. Clear excess fuel from the combustion chamber by cranking the engine several times while the spark plug is removed.
5. Install the spark plug firmly, tighten it with the spark plug wrench supplied. **DO NOT OVERTIGHTEN.**
6. Reconnect the spark plug boot.



WARNING:

Incorrect spark plug installation can result in serious engine damage.

Operation - *continued*

Operating the Trimmer

BEFORE EACH USE:

- Remove dirt and debris from the product exterior.
- Inspect the engine, tank and hoses for possible fuel leaks and repair as necessary.
- Inspect the engine cooling fins for accumulation of debris and clean as necessary.
- Inspect the entire machine for damage, loose and missing components or fasteners and repair as necessary.



WARNING:

To avoid burns from hot surfaces, never operate unit with the bottom of the engine above waist level.

Follow these steps to operate the Line Trimmer.



1. Start the trimmer.
2. Hold the trimmer at waist level with one hand on the trigger handle and the other hand on the front handle.
3. Keep a firm grip with both hands while in operation.
4. Place the product on the right side of your body with the engine behind and away from your body.
5. Cut tall grass and weeds down in a right-to-left motion. This will prevent grass from wrapping around the shaft housing and string head, which may cause damage from overheating.

If grass becomes wrapped around the string head, **STOP THE ENGINE**, disconnect the spark plug wire and remove the grass.

Prolonged cutting at partial throttle will result in oil dripping from the muffler.

Cutting Tips

1. Keep the trimmer tilted toward the area being cut; this is the best cutting area.
2. The curved shaft trimmer cuts when passing the unit from right to left. This will avoid throwing debris at the operator. Avoid cutting in the dangerous area shown in Fig. 11.
3. Use the tip of the line to do the cutting; do not force line head into uncut grass.
4. Wire and picket fences cause extra line wear, even breakage. Stone and brick walls, curbs and wood will wear the cutting line rapidly.
5. Avoid tree, shrubs, tree bark and wood mouldings.

To Advance the Cutting Line

Follow these steps to advance the cutting line.

The cutting line is advanced by tapping the cutting head on grass while running the engine at full throttle.

1. Run engine at full throttle.
2. Tap the spool retainer on ground to advance line. The line advances each time the spool retainer is tapped.

NOTE: The line trimming cut-off blade on the grass deflector will cut the line to the correct length.

To Advance the Cutting Line Manually

Follow these steps to advance the cutting line manually.

1. Stop the engine.
2. Push the spool retainer down while pulling on the nylon line(s) to manually advance the line.

Grass Deflector Line Trimming Cut Off Blade

1. The trimmer is equipped with a line trimming cut-off blade on the grass deflector.
2. For best cutting, advance line until it is trimmed to length by the cut-off blade.
3. Advance the line whenever you hear the engine running faster than normal, or when trimming efficiency diminishes. This will maintain best performance and keep the line long enough to advance properly.

Emissions Maintenance Schedule

Maintenance, replacement or repair of the emission control device and systems may be performed by any recognised Toro or Pope Service Centre.



WARNING:

Before performing any maintenance on this machine, stop the engine and disconnect the spark plug wire.

Before Each Use

1. Remove dirt and debris from the product exterior.
2. Inspect the engine, tank and hoses for possible fuel leaks and repair as necessary.
3. Inspect the engine cooling fins for accumulation of debris and clean as necessary.
4. Inspect the entire machine for damage, loose or missing components or fasteners and repair as necessary.

Cleaning the Product

1. Stop the product before cleaning.
2. Clean the exterior of the product with a damp cloth.
3. Avoid using solvents when cleaning plastic parts. Most plastics are susceptible to damage from various types of commercial solvents and may be damaged by their use.

Emission Part	Inspect Before Each Use	Every 10 Hours	Every 10-15 hours or Yearly
Fuel Tank Assembly (includes Fuel Line, Fuel Cap and Fuel Filter)	X		
Clean Air Filter		X	X
Replace Spark Plug			X

Maintenance - *continued*

Replacing and Cleaning the Air Filter

1. Stop the engine.
2. Remove the spark plug boot from the spark plug.
3. Remove the air cleaner cover (Fig. 12).

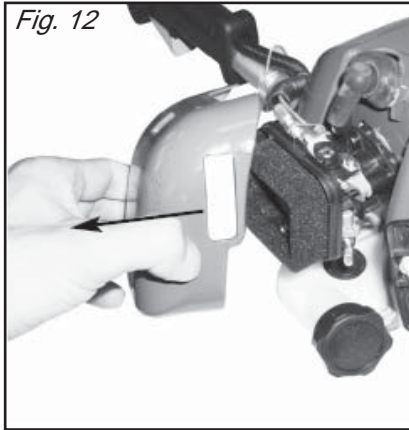

4. Remove the air filter element (Fig. 13).

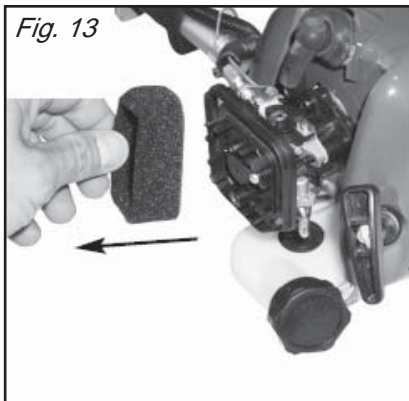

5. Inspect the element. If the element is distorted or damaged replace it with a new one.
6. Clean the air filter element by tapping it or by using compressed air.
7. Replace the filter.
8. Replace the air filter cover.
9. Tighten the air filter by turning the knob clockwise.
10. Replace the spark plug boot.

Spark Plug

This engine uses a NGK BPMR7A with an electrode gap of 0.63 mm. Use an exact replacement and replace annually. Tighten to a torque of 12-15 Nm.

Replacing the Cutting Line

See Fig. 14, 15, 16 and 17.

Follow these steps to replace the cutting line

1. Stop the trimmer.



WARNING:

Make sure the trimmer head has fully stopped rotating. Contact with a rotating trimmer head could cause personal injury.

2. Disconnect the spark plug boot.
3. Hold the bump feed and unscrew the spool retainer.
4. Remove the spool retainer by turning anti-clockwise and remove the spool from the spring head. **NOTE:** Keep the spring attached to the spool.
5. Remove any old line remaining on the spool.
6. Cut two pieces of line, each approximately 5 m long.
7. Insert a piece of line into the slot in the spool.
8. Wind the line around following the direction of the arrows on the spool, filling one half only.
9. Ensure that about 15 cm of line is not wound. Do not overfill the spool. There should be at least 6 mm space between the wound line and the outside edge of the spool.
10. Secure the line end temporarily in the slots on the upper/bottom flange.
11. Repeat steps 7 -10 for the line, filling the other half of the chamber.
12. **NOTE:** Ensure that both cutting lines are wound in the same direction and that the lines do not cross.
13. Feed each end of the line through opposite metal eyelets.
14. Before pulling through completely, ensure line is released from temporary holding slot.
15. Push spool firmly back in recess and secure the spool retainer in position.

NOTE:

Check that the bump feed head is locked in place and is installed correctly back onto the drive shaft.

NOTE:

If insufficient line is protruding from the bump feed head, depress bump feed head and pull in line to manually advance the line and to check for proper reassembly of the bump feed head.

Maintenance - *continued*

Replacing the Cutting Line

Fig. 14

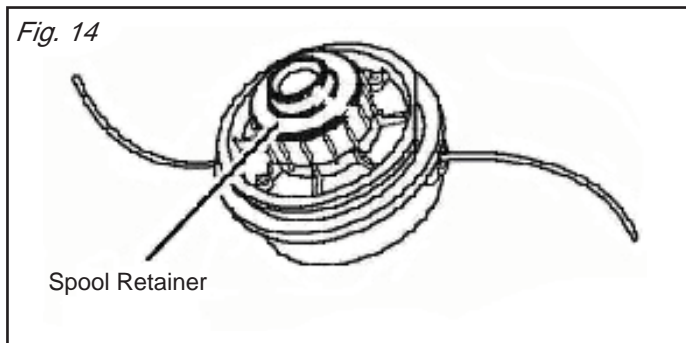

Fig. 15

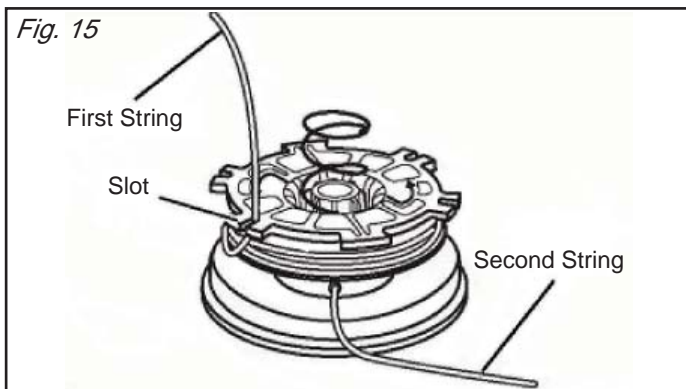

Fig. 16

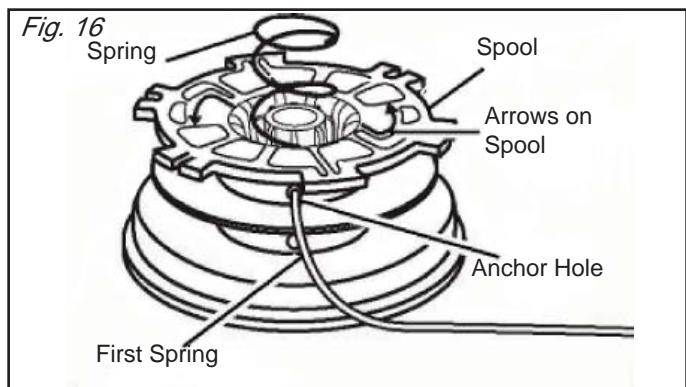
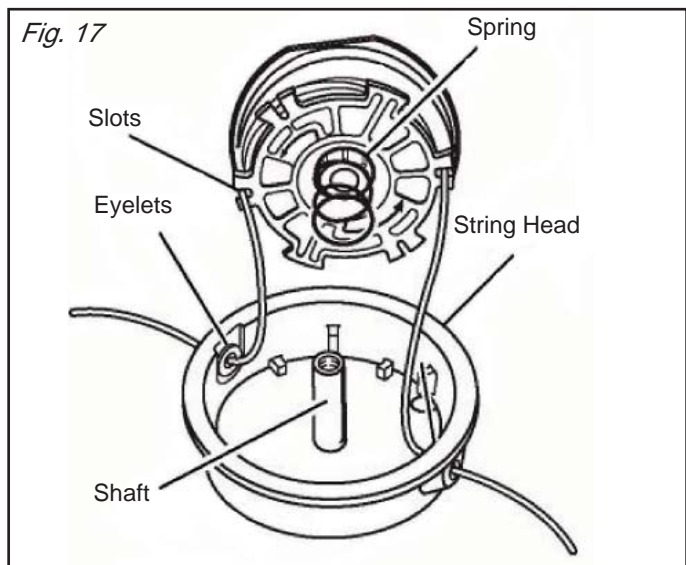

Fig. 17



To Store the Product Long Term (more than 30 days)

If you do not intend to use the product for more than one month, follow these steps to store the product long term.

1. Drain all of the fuel from the tank into a container approved for petrol.
2. Run the engine until it stops.
3. Clean all foreign materials from the product.
4. Remove the spark plug boot and then the spark plug.
5. Pour approximately 5 ml oil into the cylinder through the spark plug hole.
6. Pull the recoil starter 2 or 3 times to distribute the oil over the cylinder walls.
7. Reinstall the spark plug. Follow the instructions for spark plug replacement to ensure correct tightness.
8. Reconnect the spark plug boot.
9. Store the product in a well ventilated place that is inaccessible to children.

Note:

Keep the product away from corrosive agents such as garden chemicals.

Important:

Abide by all federal and local regulations for the safe storage, handling and disposal of petrol.

Troubleshooting

Problem	Possible Cause	Solution
Engine will not start	<ol style="list-style-type: none"> 1. Switch set to OFF position. 2. No spark. 3. No fuel. 4. Flooded engine. 5. Starter cord pulls harder now than when new. 	<ol style="list-style-type: none"> 1. Set switch to the ON position. 2. Remove the spark plug. Re-attach the spark plug and lay the spark plug on the metal cylinder. Pull the starter cord and watch for a spark at the spark plug tip. If there is no spark, repeat the test with a new spark plug. 3. Push primer bulb until the bulb is full of fuel. If the bulb does not fill, the primary fuel delivery system is blocked. If the primer bulb fills, the engine may be flooded (see next item). 4. Remove the spark plug. Turn the product so that the spark plug hole is aimed at the ground. Make sure the choke lever is set to B and pull the starter cord 10 to 14 times. This clears excess fuel from the engine. Clean and re-install the spark plug. With the trigger fully depressed, pull the starter cord three times. If the engine does not start, set the choke lever to full and follow normal starting instructions. If the engine still fails to start, repeat the procedure with a new spark plug. 5. Contact an authorised service dealer.
Engine does not reach full speed	<ol style="list-style-type: none"> 1. Check oil fuel mixture. 2. Air filter is dirty. 3. Spark arrestor screen is dirty. 	<ol style="list-style-type: none"> 1. Use fresh fuel and the correct 2 stroke oil mix. 2. Clear the air filter. 3. Clean the spark arrestor.
Line will not advance when using automatic line lengthening	<ol style="list-style-type: none"> 1. Line welded to itself. 2. Not enough line on the spool. 3. Line worn too short. 4. Line tangled on spool. 5. Engine speed too slow. 	<ol style="list-style-type: none"> 1. Lubricate with silicone spray. 2. Install more line. 3. Pull line while alternately pressing down on and releasing the retaining cap. 4. Remove line from spool and rewind. 5. Advance line at full throttle.
Retaining cap hard to turn when using automatic line lengthening	Screw threads are dirty or damaged.	Clean the threads and lubricate with grease. If this does not solve the problem, replace the retaining cap.
Grass wraps around the trimmer head assembly and the attachment shaft	<ol style="list-style-type: none"> 1. Cutting tall grass at ground level. 2. Operating the product at part throttle. 	<ol style="list-style-type: none"> 1. Cut tall grass from the top down. 2. Operate the product at full throttle.
Oil drips from motor	<ol style="list-style-type: none"> 1. Operating the product at part throttle. 2. Check oil/fuel mixture. 3. Air filter is dirty. 	<ol style="list-style-type: none"> 1. Operate the product at full throttle. 2. Use fresh fuel and the correct 2 stroke oil mix. 3. Clean the air filter.

Warranty

Petrol Operated Products Limited Warranty

Pope warrants to the original retail purchaser that this Petrol Powered Product is free from defects in material and workmanship and agrees to repair or replace, at our option, any defective product free of charge within these time periods from the date of purchase:

- Two years for Petrol Powered Trimmer, Brushcutter and Blower Vacuum products, if the product is used personal, family or household use;
- 90 days if the Petrol Powered Trimmer, Brushcutter and Blower Vacuum products are used for any other purpose, such as commercial or rental.

Instructions for obtaining Warranty Service

Any part of the Pope product found in the judgement of Toro Australia Pty Ltd to be defective in material or workmanship will be replaced by an Authorised Service Dealer for this product without charge for parts or labour. To locate your nearest Authorised Service Dealer, refer to the list on the back page of this manual, check the website or phone 1300 134 880.

The product, including any defective part must be returned to an Authorised Service Dealer for this product within the warranty period. The expense of delivering the product to the Authorised Service Dealer for warranty work and the expense of returning it back to the owner after repair or replacement will be paid for by the owner.

Proof of purchase will be required by the dealer to substantiate any warranty claim. All warranty work must be performed by a Service Dealer authorised by Toro Australia Pty Ltd to service this product.

The warranty does not cover any product that has been subject to misuse, neglect, negligence or accident or that has been operated in any way contrary to the operating instructions as specified in the Operator's Manual. This warranty does not apply to any damage to the product that is the result of improper maintenance or to any product that has been altered or modified so as to adversely affect the product's operation, performance or durability or that has been altered or modified so as to change its intended use. The warranty does not extend to repairs made necessary by normal wear, misuse or by the use of parts or accessories which are either incompatible with the product or adversely affect its operation, performance or durability.

Toro Australia Pty Ltd reserves the right to change or improve the design of any Petrol Product without assuming any obligations to modify any product previously manufactured.

ALL IMPLIED WARRANTIES ARE LIMITED TO THE DURATION OF THE STATED WARRANTY PERIOD. ACCORDINGLY, ANY SUCH IMPLIED WARRANTIES INCLUDING MERCHANTABILITY, FITNESS FOR A PARTICULAR PURPOSE, OR OTHERWISE, ARE DISCLAIMED IN THEIR ENTIRETY AFTER THE EXPIRATION OF THE APPROPRIATE TWO YEAR OR NINETY DAY WARRANTY PERIOD. TORO AUSTRALIA PTY LTD'S OBLIGATION UNDER THIS WARRANTY IS STRICTLY AND EXCLUSIVELY LIMITED TO THE REPAIR AND REPLACEMENT OF DEFECTIVE PARTS AND TORO AUSTRALIA PTY LTD DOES NOT ASSUME OR AUTHORISE ANYONE TO ASSUME FOR THEM ANY OTHER OBLIGATION. TORO AUSTRALIA PTY LTD ASSUMES NO RESPONSIBILITY FOR INCIDENTAL, CONSEQUENTIAL OR OTHER DAMAGES INCLUDING, BUT NOT LIMITED TO EXPENSE OF RETURNING THE PETROL POWERED PRODUCT TO ANY AUTHORISED SERVICE DEALER AND EXPENSE OF DELIVERING IT BACK TO THE OWNER, MECHANIC'S TRAVEL TIME, TELEPHONE OR TELEGRAM CHARGES, RENTAL OF A LIKE PRODUCT DURING THE TIME WARRANTY SERVICE IS BEING PERFORMED, TRAVEL, LOSS OR DAMAGE TO PERSONAL PROPERTY, LOSS OF REVENUE, LOSS OF USE OF THE PRODUCT, LOSS OF TIME OR INCONVENIENCE.

The above warranty does not exclude any condition or warranty implied by the Trade Practices Act 1974 or any other relevant legislation which implies any condition which cannot be excluded.

