



22cc Hedge Trimmer

Model No 101PHT22

Operator's Manual



WARNING:

To reduce the risk of injury, the user must read and understand the operator's manual. Save this manual.

READ THIS INFORMATION



Before you use your new hedge trimmer, read this manual carefully to learn how to operate and maintain your product correctly. Reading this manual will help you and others avoid personal injury and damage to the product. Although Pope designs safe state-of-the-art products, you are responsible for using the product properly and safely. You are also responsible for training persons you allow to use the product about safe operation.

Introduction

Thank you for purchasing a Pope® product.

We would like you to be completely satisfied with your new product, so feel free to contact an authorized service dealer listed at the back of this manual, for help with service, genuine Pope parts or other information you may require. Or phone the Pope Customer Service Centre for details of your nearest dealer on 1300 134 880.

The Pope warning system in this manual identifies potential hazards and special safety messages that help you and others avoid personal injury, even death. DANGER, WARNING and CAUTION are signal words that identify the level of hazard. However, regardless of the hazard, be extremely careful. Two other words "Important" and "Note" highlight other valuable information.

Signal Word	Explanation
DANGER	Indicates an imminently hazardous situation which, if not avoided, will result in death or serious injury.
WARNING	Indicates a potentially hazardous situation which, if not avoided, could result in death or serious injury.
CAUTION	Indicates a potentially hazardous situation which if not avoided, could result in death or serious injury.
Important	Advises you of important information or instructions vital to the operation or maintenance of the equipment.
Note	Advises you of additional information concerning the operation or maintenance of the equipment.

Contents

Safety Rules	4
Symbols	5
Specifications	6
Applications	6
Features	7
Unpacking	8
Operation	9
Mixing the Fuel	9
Filling the Tank	9
Starting the Product – To Start a Cold Engine	10
Operating the Hedge Trimmer	11
Maintenance	12
Cleaning the Product	13
Maintaining the Blades	13
Cleaning the Air Filter	14
Replacing the Spark Plug	15
Storing the Product	15
Troubleshooting	16
Warranty	17

Safety Rules



WARNING:





Read and understand all instructions. Failure to follow all instructions may result in serious personal injury as well as damage to product.

- **Physical Condition of the Operator.** Do not operate this product when tired, ill or under the influence of alcohol, drugs or medication.
- **Clothing Requirements.** Always wear long heavy pants, boots and gloves. Do not wear loose clothing, jewellery, short pants, sandals or go barefoot. Secure hair so that it is above shoulder level to avoid entanglement in moving parts.
- **Protective Accessories Requirements.** Wear safety eye protection and thick work gloves when operating this product. Wear hearing protection during extended periods of operation.
- **Condition of Product Before Use.** Inspect the product before each use, particularly the throttle trigger, stop switch, and cutting tool. Replace damaged parts. Check for fuel leaks. Make sure all fasteners are in place and secure. Replace blades or parts that are cracked, chipped or damaged in any way. Always keep the blade sharp. Make sure the safety guard is properly installed and in the position recommended by the manufacturer.
- **Proper Stance.** Keep firm footings and balance. Do not overreach. Keep the hedge trimmer away from all parts of your body and away from hot surfaces.
- **Exhaust Gases.** Never start or run the product inside a closed room or building: breathing exhaust fumes can cause illness or death.
- **Fuelling.** Mix and pour fuel outdoors where there are no sparks or flames. Slowly remove the fuel cap only after stopping the engine. Do not smoke while fuelling or mixing fuel. Wipe spilled fuel from the product. Move at least 9m from the fuelling source and site before starting the engine.
- **Use of product.** Never allow children or infirm persons to use the tool. Never allow other persons who are unfamiliar with the operating instructions to use the tool.
- **Work Area.** Clear the area to be cut before each use. Remove all objects such as nails, wire, string or any obstacles which might get in the way while working. Clear the area of bystanders, pets and children. At a minimum, keep all bystanders, pets and children outside a 15m radius. Because there still may be a risk to bystanders from thrown objects, bystanders should be encouraged to wear eye protection. If you are approached while operating the product, stop the engine.
- **Dangerous Environments.** To avoid falling, do not use the product in damp or wet locations.
- **Use the Right Product.** Use the product for the intended purpose only – ie for trimming leaves and branches from trees, shrubs and hedges.
- **Use the Equipment Correctly.** Do not grip any part of the hedge trimmer apart from the handles during operation. Never raise the hedge trimmer above waist height.
- **Kick back.** Kick back may occur when the blade contacts a solid object in the cutting area. Ensure that the cutting blades are kept clear of fences, posts, wires etc. This is more likely to occur in areas where it is difficult to see the material being cut.
- **Stopping the Product.** A coasting blade can cause injury while it continues to spin after the engine is stopped or the throttle is released. Maintain proper control until the blade has completely stopped moving.
- **Use the Blade Cover** whenever transporting, or when the hedge trimmer is being stored or is not in use.

Save These Instructions

Symbols

The following symbols are located on the product. Please study them and learn their meaning. Proper interpretation of these symbols allows you to operate the product better and safer.

Symbol	Name	Explanation
	Safety Alert	Indicates danger, warning or caution. Attention is required in order to avoid serious personal injury. May be used in conjunction with other symbols or pictographs.
	Wear Gloves	Protect your hands with gloves when handling the hedge trimmer. Heavy duty non-slip gloves will provide extra safety and help to improve your grip.
	Read Operator's Manual	Read the Operator's Manual before starting or operating this product. Failure to follow operating instructions and safety precautions in the Operator's Manual can result in serious injury.
	Eye and Ear Protection	Thrown objects can cause severe eye injury. Wear eye protection when operating this product. Wear hearing protection during extended periods of operation.

Specifications

Model 101PHT22 22cc Hedge Trimmer

Engine:	22.5 cc Full Crank
Blade Cutting Length:	600 mm
Cutting Style:	Dual action
Weight (Dry):	5.6 kg
Fuel Tank Capacity:	0.6 litres
Maximum Cutting Diameter:	25 mm

Applications

Use this product for the following applications:

- Trimming and shaping topiary
- Regular trimming of bushes and shrubs
- Shaping and pruning bushes and shrubs



Features

Before using the product, familiarize yourself with all operating features and safety requirements. However, do not let familiarity with the product make you careless.



WARNING:

Exercise caution when using the product. Careless actions, for even a fraction of a second, can result in serious or fatal injury.

Your new product is equipped with the following features:

Engine

The engine is powerful and easy to start. It is effectively counterbalanced and has a full crank which allows for less vibration and greater durability.

Handles

The front handle should be gripped firmly with the left hand while the rear handle provides support for the right hand. Both hands must be used while operating the trimmer.

Cutter Blade Guard

Covers the blade when not in use and provides additional safety while transporting.

Safety Guard

The large safety guard helps protect you from the blade and flying debris.

Blade Guards

Two blade guards for each side of the hedge trimmer protect the blades during storage and transportation.



WARNING:

Do not attempt to modify this product or create accessories not recommended for use with this product. Any such alteration or modification is misuse and could result in a hazardous condition leading to serious personal injury and will void your warranty.

Unpacking

Instructions

- Carefully remove the product from the box.
- Inspect the product carefully to make sure no breakage or damage occurred during shipping.
- Do not discard the packing material until you have carefully inspected and satisfactorily operated the product.

Packing List

22.5cc Hedge Trimmer

2 Blade Safety Guards

Fuel Mixing Bottle

Assembly Tools – 1 bag including:

- Spark plug wrench (1)

- Spanner (1)

Operator's Manual



WARNING:

If any parts are missing, do not operate the product until the missing parts are replaced.

Failure to do so could result in serious personal injury.

Operation

Mixing the fuel



DANGER:

Petrol is extremely flammable and explosive. A fire or explosion from petrol will burn you and others.

This product is powered by a 2 stroke engine and requires pre-mixing petrol and 2 stroke oil. The oil mix should be 25:1. Never mix petrol and oil directly in the engine tank.

Use unleaded petrol intended for motor vehicle use with an Octane rating of 87 ([R + M] / 2) or higher. Purchase fuel from a reputable fuel supplier.

Use the mixing container provided to mix the oil and petrol in the correct quantities.

Petrol	Oil
1 litre	40ml
2 litres	80ml
3 litres	120ml
4 litres	160ml
5 litres	200ml

Mix only enough fuel for your immediate needs. Fuel should not be stored for more than 30 days.

Follow these steps to mix the fuel:

1. Use the container provided for mixing fuel.
2. Mix the 2 stroke engine oil with unleaded petrol in the container provided at the rate of 25 parts petrol to 1 part oil.
3. Mix the fuel thoroughly and also each time before re-fuelling.
4. Mix in small quantities. Do not mix more fuel than you expect to use within a 30 day period.
5. Store fuel only in a clean, safe, approved container for petrol – not the fuel mixing bottle provided.



Filling the Tank



WARNING:

Always stop the engine before filling the tank. Never add fuel to a machine with a running or hot engine. Move at least 9m away from the refuelling site before starting the engine. Do not smoke while filling the tank. Do not add fuel to the tank close to an open fire or sparks. Never add fuel to the tank in a closed or non-ventilated area.

Follow these steps to fill the tank:

1. Clean the surface around the fuel tank to prevent contamination.
2. Loosen the fuel cap by turning it counter clockwise.
3. Pour the fuel mixture carefully into the tank.
4. Clean and inspect the gasket.
NOTE: Replace the fuel cap if the gasket is damaged.
5. Install the fuel cap and tighten it by turning it clockwise.



WARNING:

Check for fuel leaks. If you find any leaks, correct the problem before using the product.

6. Wipe spilled fuel from the product.
7. Move at least 9 metres away before starting the product.

NOTE: It is normal for the engine to emit smoke during use.

Operation – continued

Starting the Product

Starting the product depends on whether the engine is cold or warm.



WARNING:

The recoil starter can be damaged by abuse.

Never pull the starter cord to its full length.

Always engage the starter before cranking the engine.

Always rewind the starter cord slowly.



CAUTION:

Operating the machine with loose, missing or damaged components could allow the engine to over-speed, possibly causing serious engine damage.

Inspect the entire machine for damaged, loose or missing components or fastenings and repair as necessary.

To Start a Cold Engine

Follow these steps to start a cold engine:

1. Lay the product on a flat bare surface.
2. Slide the switch to ON by pushing the switch downwards, away from the STOP position.
3. Push the primer bulb repeatedly until fuel comes into the primer pump. For new engines or engines that have been refueled this may require numerous attempts.
4. Slide the choke lever up to the position marked  (choke is closed).
5. Holding the machine handle firmly with your right hand, pull the starter cord slowly until you feel the starter engage.

6. Start the machine by pulling the starter cord upward rapidly. If necessary, repeat step 5 two or three times until the engine starts.
7. Push choke lever down. Excessive cranking of the choke lever will cause the engine to flood making it difficult to start.
8. If the engine starts but does not run, open choke and continue to crank engine.

NOTE: When starting the engine for the first time, or after refueling, it may take longer for the fuel to reach the engine and become operational. You may need to repeat the steps several times in order to start the engine. If the engine will not start after repeated attempts, you should open the throttle and choke fully, and continue pulling the starter cord until the motor starts, making sure there is no danger of persons approaching the head while starting.

NOTE: If the product starts, let it run for 30 seconds before using it. If the product does not start, repeat the previous steps.



WARNING:

To reduce the risk of injury from blade contact, do not attempt to “drop start” the hedge trimmer. Only ever start the hedge trimmer on firm flat ground or other solid surface.



WARNING:

Do not start the Hedge Trimmer with the Blade Guards fitted.

Operation – continued

Operating the Hedge Trimmer

Do not cut any material other than hedges and shrubs. The hedge trimmer must only be used for the operations described in this Operator's Manual.

See Figs 1 and 2

Follow these steps to use the Hedge Trimmer:

1. When trimming, the blade should be tilted approximately 15 degrees towards the hedge. Always trim from the bottom upwards.
2. Trim the sides of the hedge first and then trim the top.
3. If the branches are very long, they should be cut back in several stages.
4. Make sure that there are no objects in the hedge, such as railings, that could damage the blade.
5. If the blade becomes jammed, always turn off the engine and wait for the hedge trimmer to cool before clearing the obstruction.
6. Do not force the Hedge Trimmer to cut over sized branches. These should be cut by hand using secateurs or shears.

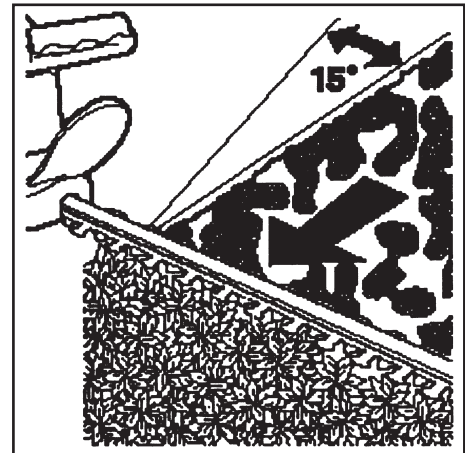

Fig 1

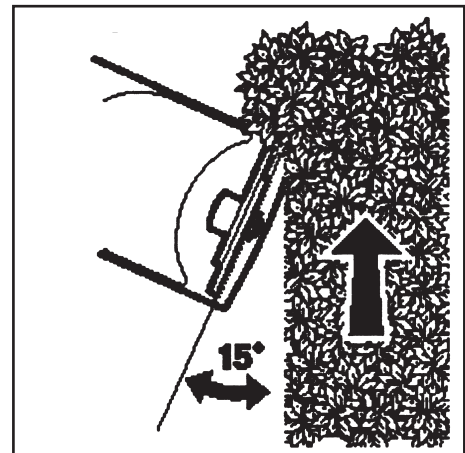

Fig 2



WARNING:

Before using this Hedge Trimmer, make sure that you have read all of the safety instructions.



WARNING:

Always hold your hedge trimmer with both hands. Never attempt to operate this machine with one hand. Loss of control could result in serious or fatal injury.

Maintenance

Emissions Maintenance Schedule

Maintenance, replacement or repair of the emission control device and systems may be performed by any authorised Toro or Pope Service Dealer.



WARNING:

Before performing any maintenance on this machine, stop the engine and disconnect the spark plug.

Emission Part	Inspect before each use	Every 10 hours	Every 10 - 15 hours or yearly
Fuel Tank Assembly (includes Fuel Lines, Fuel Cap and Fuel Filter)	X		
Clean Air Filter		X	X
Replace Spark Plug			X



WARNING:

When replacing parts other than engine or emissions parts, use only Pope replacement parts. Use of any other parts may create a hazard or cause product damage.

Maintenance – *continued*

BEFORE EACH USE:

- Remove dirt and debris from the product exterior.
- Inspect the engine, tank and hoses for possible fuel leaks and repair as necessary.
- Inspect the engine cooling fins for accumulation of debris and clean as necessary.
- Inspect the entire machine for damage, loose and missing components or fasteners and repair as necessary.

CLEANING THE PRODUCT:

- Stop the product before cleaning.
- Clean the exterior of the product with a damp cloth.
- Avoid using solvents when cleaning plastic parts. Most plastics are susceptible to damage from various types of commercial solvents and may be damaged by their use.
- Scrape debris away from air intake vents on both sides of the motor housing.



CAUTION:

Keeping air intake vents free of leaves and debris prevents motor overheating and possible failure.

Maintaining the Blades

- Use a resin solvent on the cutter blades. Resin solvent protects the blades and has anti-corrosive properties. Use the resin solvent before and after work. Then start and run the hedge trimmer briefly to ensure even distribution along the blades.
- Check the condition of the cutting tool at regular intervals. Replace damaged or dull cutting blades immediately even if they only have superficial cracks.
- Never try to repair damaged blades by welding, straightening or modifying the shape. This may cause parts of the blade to come off and result in serious or fatal injuries.

NOTE: Depending on the type of fuel used, the type and amount of oil used, and/or your operating conditions, the exhaust port and muffler may become blocked with carbon deposits. If you notice a power loss with your petrol powered tool, you may need to remove these deposits to restore performance. We highly recommend that only qualified service technicians perform this service.

Maintenance – continued

Cleaning the Air Filter

See Fig. 3

Follow these steps to clean the air filter.

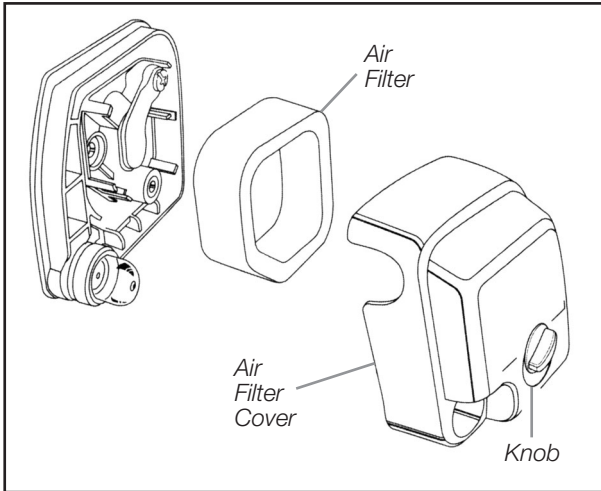

Fig. 3

1. Stop the engine.
2. Remove the spark plug boot.
3. Loosen the air cleaner cover by turning the knob counter clockwise.
4. Remove the air filter cover.
5. Remove the air filter element.
6. Inspect the element. If the element is distorted or damaged replace it with a new one.
7. Wash the element in clean fuel and squeeze or blow dry.
8. Wash the air cleaner in clean fuel and wipe or blow dry.
9. Rinse the air filter and let it dry completely.
10. Work two drops of oil into the air filter.
11. Replace the air filter (fits only one way).
12. Replace the air filter cover.
13. Tighten the air filter cover by turning the knob clockwise.
14. Replace the spark plug boot.

Maintenance – *continued* & Storing the Product

Replacing the Spark Plug

NOTE: Before removing the spark plug, thoroughly clean the spark plug and cylinder head area.

The Pope Hedge Trimmer 101PHT22 uses an NGK BP7A spark plug. Use an exact replacement and replace annually.

Follow these steps to replace the spark plug.

1. Ensure the engine is cool before servicing the spark plug.
2. Remove the spark plug boot.
3. Loosen the spark plug by turning it counter clockwise with a socket.
4. Remove the spark plug.
5. Hand thread the new spark plug, turning it clockwise. **Do not over tighten.**



CAUTION:

Be careful not to cross-thread the spark plug. Cross threading will seriously damage the product.

Storing the Product

Storing the product differs depending on the amount of time it will be in storage.

To Store the Product Short Term

Follow these steps to store the product short term.

1. Clean all foreign material from the product.
2. Store in a well-ventilated place that is inaccessible to children.

To Store the Product Long Term (more than 30 days)



CAUTION:

Never store this product with any fuel remaining in the tank, fuel lines or carburettor. Your warranty does not include coverage for damage covered by stale or contaminated fuels.

If you do not intend to use the product for more than one month, follow these steps to store the product long term.

1. Drain all of the fuel from the tank into a container approved for petrol.
2. Run the engine until it stops.
3. Clean all foreign materials from the product.
4. Remove the spark plug boot, and then the spark plug.
5. Pour approximately 5ml oil into the cylinder through the spark plug hole.
6. Pull the recoil starter 2 or 3 times to distribute the oil over the cylinder walls.
7. Reinstall the spark plug. Follow the instructions for spark plug replacement.
8. Reconnect the spark plug boot.
9. Store the product in a well-ventilated place that is inaccessible to children.

NOTE: Keep the product away from corrosive agents such as garden chemicals.

IMPORTANT: Abide by all federal and local regulations for the safe storage, handling and disposal of petrol.

Troubleshooting:

Problem	Possible Cause	Solution
Engine will not start	<ol style="list-style-type: none"> 1. Switch set to OFF position. 2. No spark. 3. No fuel. 4. Flooded engine. 5. Starter cord pulls harder now than when new. 	<ol style="list-style-type: none"> 1. Set switch to the ON position. 2. Remove the spark plug. Re-attach the spark plug and lay the spark plug on the metal cylinder. Pull the starter cord and watch for a spark at the spark plug tip. If there is no spark, repeat the test with a new spark plug. 3. Push primer bulb until the bulb is full of fuel. If the bulb does not fill, the primary fuel delivery system is blocked. If the primer bulb fills, the engine may be flooded. (See next item.) 4. Remove the spark plug. Turn the product so that the spark plug hole is aimed at the ground. Make sure the choke lever is open and pull the starter cord 10 to 14 times. This clears excess fuel from the engine. Clean and re-install the spark plug. With the trigger fully depressed, pull the starter cord 3 times. If the engine does not start, set the choke lever to closed and follow normal starting instructions. If the engine still fails to start, repeat the procedure with a new spark plug. 5. Contact an authorised service dealer.
Engine does not reach full speed	<ol style="list-style-type: none"> 1. Check oil fuel mixture. 2. Air filter is dirty. 3. Spark arrestor screen is dirty. 	<ol style="list-style-type: none"> 1. Use fresh fuel and the correct 2 stroke oil mix. 2. Clear the air filter. 3. Clean the spark plug arrestor.
Oil drips from muffler	<ol style="list-style-type: none"> 1. Operating the product at part throttle. 2. Check oil/fuel mixture. 3. Air filter is dirty. 	<ol style="list-style-type: none"> 1. Operate the product at full throttle. 2. Use fresh fuel and the correct 2 stroke oil mix. 3. Clean the air filter.

Warranty

Petrol Operated Products Limited Warranty

Pope warrants to the original retail purchaser that this Petrol Powered Product is free from defects in material and workmanship and agrees to repair or replace, at our option, any defective Product free of charge within these time periods from the date of purchase:

- Two years for Petrol Powered Trimmer, Brushcutter and Blower Vacuum Products, if the Product is used for personal, family, or household use;
- 90 days if the Petrol Powered Trimmer, Brushcutter and Blower Vacuum Products are used for any other purpose, such as commercial or rental.

Instructions for Obtaining Warranty Service

Any part of the Pope Product found in the reasonable judgement of Toro Australia Pty Limited to be defective in material or workmanship will be repaired or replaced by an Authorised Service Dealer for this product without charge for parts or labour. To locate your nearest authorised service dealer, refer to the list on the back page of this manual, check the website, or phone 1300 134 880.

The Product, including any defective part must be returned to an Authorised Service Dealer for this product within the warranty period. The expense of delivering the product to the Authorised Service Dealer for warranty work and the expense of returning it back to the owner after repair or replacement will be paid for by the owner.

Proof of purchase will be required by the dealer to substantiate any warranty claim. All warranty work must be performed by a Service Dealer authorised by Toro Australia Pty Limited to service this product.

The warranty does not cover any product that has been subject to misuse, neglect, negligence or accident or that has been operated in any way contrary to the operating instructions as specified in the Operator's Manual. This warranty does not apply to any damage to the Product that is the result of improper maintenance or to any Product that has been altered or modified so as to adversely affect the product's operation, performance or durability or that has been altered or modified so as to change its intended use. The warranty does not extend to repairs made necessary by normal wear, misuse or by the use of parts or accessories which are either incompatible with the product or adversely affect its operation, performance or durability.

Toro Australia Pty Limited reserves the right to change or improve the design of any Petrol Product without assuming any obligations to modify any product previously manufactured.

ALL IMPLIED WARRANTIES ARE LIMITED TO THE DURATION OF THE STATED WARRANTY PERIOD. ACCORDINGLY, ANY SUCH IMPLIED WARRANTIES INCLUDING MERCHANTABILITY, FITNESS FOR A PARTICULAR PURPOSE, OR OTHERWISE, ARE DISCLAIMED IN THEIR ENTIRETY AFTER THE EXPIRATION OF THE APPROPRIATE TWO-YEAR OR NINETY DAY WARRANTY PERIOD. TORO AUSTRALIA PTY LIMITED'S OBLIGATION UNDER THIS WARRANTY IS STRICTLY AND EXCLUSIVELY LIMITED TO THE REPAIR AND REPLACEMENT OF DEFECTIVE PARTS AND TORO AUSTRALIA PTY LIMITED DOES NOT ASSUME OR AUTHORISE ANYONE TO ASSUME FOR THEM ANY OTHER OBLIGATION. TORO AUSTRALIA PTY LIMITED ASSUMES NO RESPONSIBILITY FOR INCIDENTAL, CONSEQUENTIAL OR OTHER DAMAGES INCLUDING, BUT NOT LIMITED TO EXPENSE OF RETURNING THE PETROL POWERED PRODUCT TO AN AUTHORISED SERVICE DEALER AND EXPENSE OF DELIVERING IT BACK TO THE OWNER, MECHANIC'S TRAVEL TIME TELEPHONE OR TELEGRAM CHARGES, RENTAL OF A LIKE PRODUCT DURING THE TIME WARRANTY SERVICE IS BEING PERFORMED, TRAVEL, LOSS OR DAMAGE TO PERSONAL PROPERTY, LOSS OF REVENUE, LOSS OF USE OF THE PRODUCT, LOSS OF TIME OR INCONVENIENCE.

The above warranty does not exclude any condition or warranty implied by the Trade Practices Act 1974 or any other relevant legislation which implies any condition which cannot be excluded.

Authorised Pope Service Dealers

AUST. CAPITAL TERRITORY

Mitchell Lawnmower
Centre
MITCHELL
(02) 6241 4806

NEW SOUTH WALES

AgriFarm Implements
TAREE
(02) 6552 6888

AgriMow
COFFS HARBOUR
(02) 6652 9893

Barry Austin Mowers
FORSTER
(02) 6554 6935

Bega Farm Supplies
BEGA
(02) 6492 4466

Bike and Power
DURAL
(02) 9651 7170

Bill's Mudgee Chainsaw
Centre
MUDGE
(02) 6372 4122

Bridge Mower &
Chainsaw Centre
EAST GOSFORD
(02) 4325 2107

Central West Mowers
& Chainsaws
ORANGE
(02) 6362 0681

Cooma Power
Equipment
COOMA
(02) 6452 2622

Dawmac Industries
BERRIGAN
(03) 5885 2382

Deni Bike & Boat
DENILIQUIN
(03) 5881 5255

Dubbo Mowers &
Chainsaws
DUBBO
(02) 6882 3122/
(02) 6882 9499

Farm Moto
LISMORE
(02) 6622 3999

Grafton Power Products
GRAFTON
(02) 6642 2880

Harvey's Mower Centre
WAGGA WAGGA
(02) 6925 2234

J & P Motorcycles
GRIFFITH
(02) 6964 2422

Keith Simmons
Engineering
YOUNG
(02) 6382 3999

Ken Mathews Mower
& Auto Centre
ULLADULLA
(02) 4455 1645

LW Burgess Pty Ltd
ARMIDALE
(02) 6772 2227

Lawnpower Pty Ltd
NOWRA
(02) 4421 4466

Macarthur Mowers
CAMDEN
(02) 4655 7793/ (02) 4655 6242

Moruya Mower &
Chainsaw Centre
MORUYA
(02) 4474 3322

Mower World
WAUCHOPE
(02) 6585 2053

Newcastle Chainsaws
ISLINGTON
(02) 4961 1332

Newcastle Chainsaws
RAYMOND TERRACE
(02) 4987 3837

Ranger Geale Enterprises
GOULBURN
(02) 4821 4266

S&T Haddad Mowers
MOREE
(02) 6752 4906

Scone Outdoors
SCONE
(02) 6545 3033

Small Engine Services
GLEN INNIS
(02) 6732 1441

Tamworth Small Engines
TAMWORTH
(02) 6765 9737

The Irrigation Specialists
LEETON
(02) 6953 6700

The Mowers Warehouse
LITHGOW
(02) 6351 4008

Tinks
MACKSVILLE
(02) 6568 2344

Town & Country Water Shop
BATHURST
(02) 6331 9622

WH Ireland & Sons
MITTAGONG
(02) 4872 1999

Welvin Mower & Gas
NTH RICHMOND
(02) 4571 1662

NORTHERN TERRITORY

Winnellie Mower Repairs
WINNELLIE
(08) 8984 4529

QUEENSLAND

Aussie Mower Centre
HERVEY BAY
(07) 4125 3152

Boat or Mowers
GLADSTONE
(07) 4972 0135

Braschs Pty Ltd
CAIRNS
(07) 4051 1411

Casali's
MAREEBA
(07) 4092 3841

David Evans Group
GATTON
(07) 5462 1266

David Evans Group
BILOELA
(07) 4992 1099

Dover & Sons
BEAUDESERT
(07) 5541 1977

Dover & Sons
BOONAH
(07) 5463 1388

Downs Mower Centre
TOOWOOMBA
(07) 4632 4000

Mower World
OXENFORD
(07) 5573 4388

Jackson's Mower Centre
MACKAY
(07) 4957 5450

Kel's Chainsaws &
Small Motors
EMERALD
(07) 4982 4701

Keppel Outdoor Products
YEPPON
(07) 4925 0600

Mudgeeraba Mower
Centre
MUDGEERABA
(07) 5530 4477

Nanango Motors
NANANGO
(07) 4163 1108

Nowa Power Products
BUNDEBERG
(07) 4153 1722

Rimrock Agencies
ROCKHAMPTON
(07) 4927 7033

Schilling Small Engines
MARYBOROUGH
(07) 4123 2833

Southside Small Engines
CAPALABA
(07) 3245 6011

Southwest Pumps,
Solar & Small Engines.
ROMA
(07) 4622 4528

Sunstate AG
DALBY
(07) 4672 3333

The Big Mower
BEERWAH
(07) 5494 6151

The Mower Place
BROWNS PLAINS
(07) 3800 4433

The Mower Supastore
BRENDALE
(07) 3205 1299

The Mower Warehouse
CABOOLTURE
(07) 5495 8822

The Watershed
INNISFAIL
(07) 4061 6177

Vic's Mowers &
Small Engines
MOSSMAN
(07) 4098 1600

Warwick Westside
Chainsaws & Mowers
WARWICK
(07) 4661 2032

SOUTH AUSTRALIA

Mower Plus
SALISBURY SOUTH
(08) 8250 5666

Oaklands Road Mower
Centre
SOMERTON PARK
(08) 8294 9799

Peter Jennings Pumps
MT GAMBIER
(08) 8725 0722

TASMANIA

Central Coast Mower
Market
WEST ULVERSTONE
(03) 6425 3318

Eastern Shore Mowers
& Cycles
LINDISFARINE
(03) 6243 7776

Pellows Saws & Mowers
INVERMAY
(03) 6326 5722

Pellows Saws & Mowers
DEVONPORT
(03) 6424 8364

VICTORIA

Alphine Mowers
MONBULK
(03) 9752 0488

Bendigo Mower Service
BENDIGO
(03) 5443 5242

Benalla Chainsaws
BENALLA
(03) 5762 6177

Black's Machinery
NAGAMBIE
(03) 5794 2534

Bob Crosby & Co.
WODONGA
(02) 6024 1333

Bolton Motorcycles &
Power Equipment
KYNETON
(03) 5422 2255

Central Gippsland
Mowers & Chainsaws
MORWELL
(03) 5134 8899

Dawn Mowers
SURREY HILLS
(03) 9830 5444

Drouin Mowers &
Chainsaws
DROUIN
(03) 5625 1079

Leongatha
LEONGATHA
(03) 5662 4044

Gendore
TOORADIN
(03) 5998 3216

Gisborne Power
Products
GISBORNE
(03) 5428 8844

Hastings Mowers
HASTINGS
(03) 5979 1382

Henderson Mowers
BALLARAT
(03) 5331 1618

JR's Mowers & Chainsaws
BAIRNSDALE
(03) 5152 3202

Magic Mowers
MILDURA
(03) 5022 7088

Mariot's Motor Cycles
& Equip P/L
LEONGATHA
(03) 5662 2028

Molin Motorcycles &
Marine
KOONDRUCK
(03) 5451 1500

Morrington Mowers
MORNINGTON
(03) 5977 1488

Mortons Machinery
RINGWOOD
(03) 9870 7133

Mower Corner
COLAC
(03) 5231 5022

Mowers Galore
NORTH GEELONG
(03) 5272 1066

Mowers Galore
GROVEDALE
(03) 5244 0620

Philip Russell
Motorcycles
WARRNAMBOOL
(03) 5562 0222

Powerquip Mower &
Chainsaw Centre
DOVETON
(03) 9793 3177

Powerquip Mower &
Chainsaw Centre
HALLAM
(03) 9796 5045/
(03) 9796 3687

Roy Hill Motors
SHEPPARTON
(03) 5821 8877

Stihl Echuca Sales &
Service
ECHUCA
(03) 5480 9566

Stihl Shop Seymour
SEYMOUR
(03) 5799 1215

T&I Horticulture
SWAN HILL
(03) 5032 4555

Vin Rowe Farm Machinery
WARRAGUL
(03) 5623 1362

Yarra Glen Mower Centre
YARRA GLEN
(03) 9730 1988

WESTERN AUSTRALIA

Busselton Mower World
BUSSELTON
(08) 9754 1969

Cloverdale Hardware
CLOVERDALE
(08) 9479 4383

Eastern Hills Saws &
Mowers
MUNDARING
(08) 9295 2466

Geraldton Mower Repairs
GERALDTON
(08) 9964 4036

Star Sales & Service
ALBANY
(08) 9842 2455