

Introduction**100 Series Valve**

Built on proven technologies and components, the Irritrol 100 Series valves are tough, reliable, and service-friendly. A self-cleaning metering system and 220 PSI rating assures years of trouble-free performance.

100S Series "Scrubber" Valve

Constructed of heavy-duty, glass-reinforced nylon, high grade stainless steel, brass and EPDM rubber materials, the 100 Series scrubber valves resist clogging. The patented continuous scrubbing mechanism actively fights dirt, algae and other particles from disrupting the functionality of the valve. The 100 Series scrubber valves are true dirty water irrigation valves, able to handle the harsh chemicals found in dirty water systems, such as chlorines, chloramines and water treated with ozones.

Installation Recommendations

- In commercial installations, it is advantageous to install the valves in a valve box. This enables the valve to be easily located, accessed, and maintained.
- Partially fill the bottom of the valve box with clean aggregate to facilitate drainage.
- Locate the valve box away from structures, hardscape features (such as sidewalks), and large planting locations.
- Locate the valve box in shrub beds and at right angles to structure locations.
- If valves are installed below grade *without* a valve box, access to the top of the valve should be provided by using a section of 4" PVC pipe and a valve cover installed directly over each valve.

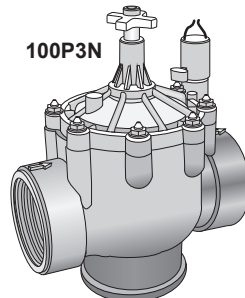
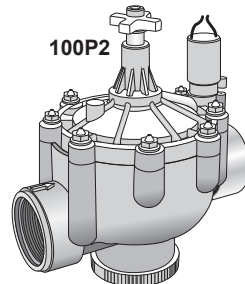
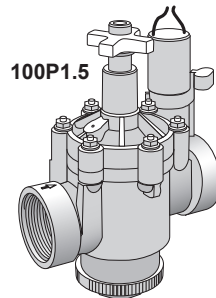
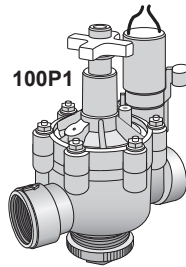

Features

100 Series Valve

- 220 PSI maximum pressure rating
- Removable, self-cleaning metering system
- Precise pressure control with optional Omni-Reg® pressure regulator (field installed)
- Manual flow control: adjustable to zero flow
- Internal manual bleed screw: bleeds internally downstream
- External manual bleed screw: bleeds to atmosphere, allows cleaning of metering rod and provides maximum flushing

100S Series "Scrubber" Valve

- All the great features of the 100 Series valve.
- Continuous scrubbing turbine actively cleans the metering device for consistent valve operation in dirty water applications.

Installation Guidelines



Using pipe dope on valve connections can cause thread damage and failure of the valve body.

Must use PTFE tape with pipe thread sealant to prevent leaks from threads.

- Note the flow direction arrows on the bonnet or body and install accordingly.
- The valve can be installed at any angle without affecting operation.
- The valve body plug and o-ring must be properly installed in the unused inlet.
- Use direct-burial wire, utilizing different color codes for each station control wire and one color for the common wire to all valves.
- Waterproof wire splice connectors are absolutely essential for proper electric control system operation. Follow the installation instructions provided with the connectors for optimum waterproof splice protection.
- Leaving a wire expansion loop at each valve location on long-run wire lengths is recommended.

Specifications

Models:

100/100S Series electric
1", 1½", 2", and 3"

Body Style:

Globe/Angle with female threads (all models)
BSP threads available

Dimensions:

1": 6¾" H x 3⅝" W
1½": 7¼" H x 3" W
2": 9½" H x 6⅞" W
3": 11¾" H x 6¾" W

Flow range: 5 - 300 GPM

Burst pressure safety rating:

450-500 PSI

Operating Pressure:

20-220 PSI maximum

Minimum pressure differential:

20 PSI

(between inlet and outlet)

Solenoid (standard): 24 VAC
Inrush: 0.40 amps, 11.50 VA; Max.
Inrush: 0.50 amps
Holding: 0.20 amps, 5.75 VA; Max.
Holding: 0.30 amps

Voltage Requirement (based on inlet pressure):

22.5 V a.c. @ 220 PSI
21.1 V a.c. @ 200 PSI
20.2 V a.c. @ 175 PSI
19.1 V a.c. @ 150 PSI
18.2 V a.c. @ 125 PSI
16.1 V a.c. @ 75 PSI
16.0 V a.c. @ 50 PSI

Valve Operation

Flow Control

Flow control reduces the flow and pressure to valve outlet. By turning the control handle clockwise, the flow will be gradually reduced to zero.

Internal Manual Bleed Knob

The internal manual bleed system is used to manually operate the valve. Turning the internal bleed knob (located beneath the solenoid) counterclockwise allows water to bleed downstream from the diaphragm chamber.

Internal pressure is relieved from the top of the diaphragm, allowing the valve to open. Turning the bleed knob clockwise until tight shuts off the discharge enabling pressure to build within the diaphragm chamber, causing the valve to close.

External Manual Bleed Knob (flush mode)

The external manual bleed knob, located on top of the flow control handle, is used for system flushing. Turning this knob counterclockwise allows water in the diaphragm chamber to vent to atmosphere, creating maximum opening power and debris flushing action. This operation bypasses the regulator (if installed) and opens the valve fully, regardless of regulator setting. In addition, the metering rod (attached to the external bleed knob) can be easily removed for cleaning as necessary.

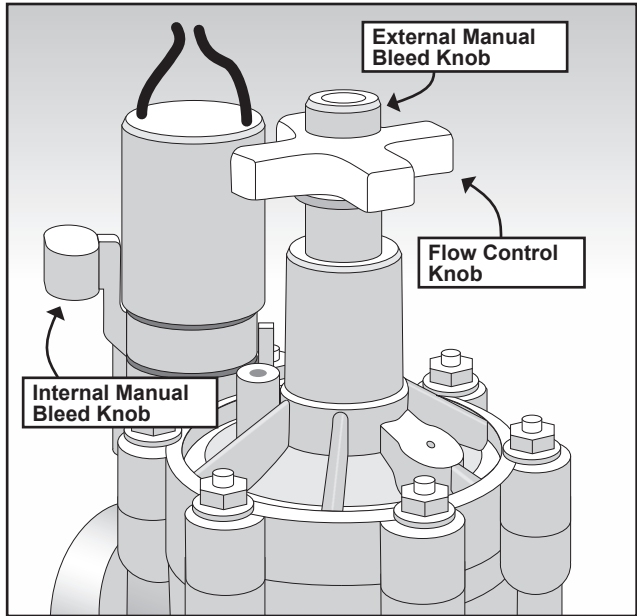

100S Scrubber Operation

Continuous scrubbing turbine actively cleans the metering device for consistent valve operation in dirty water applications.

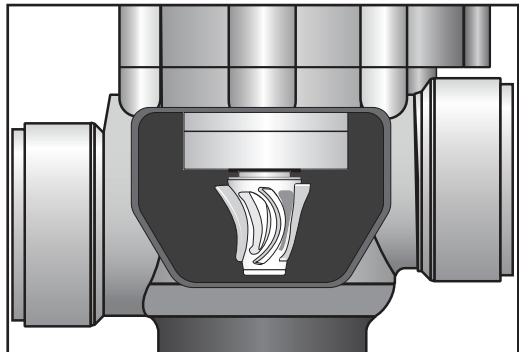

Patented scrubber impeller

Friction Loss Chart (US PSI)



For optimum performance when designing a system, be sure to calculate total friction loss to ensure sufficient downstream pressure. For optimum regulation performance, size regulating valves toward the higher flow ranges.

100 Series

Size	Config.	5	10	20	30	40	50	60	70	80	90	100	110	120	130	140	150	180	200	225	250	275	300	
1"	globe	6.3	4.2	3.2	4.1	7.2	10.9																	
	angle	6.3	4.2	3.1	2.7	4.8	7.9																	
1.5"	globe				1.6	2.3	3.6	5.2	7.0	9.2	11.7	14.4	17.5											
	angle				1.3	1.6	2.8	4.0	5.5	7.1	9.0	11.0	13.3											
2"	globe									2.1	2.7	3.3	4.0	4.8	5.6	6.5	7.5	8.05						
	angle									1.2	1.6	2.0	2.4	2.8	3.3	3.9	4.4	5.1						
3"	globe																2.7	4.1	5.0	6.3	7.8	9.4	11.2	
	angle																2.6	3.7	4.5	5.6	6.8	8.0	9.5	

GPM Flow by Size

100S "Scrubber" Series

Size	Config.	5	10	20	30	40	50	60	70	80	90	100	110	120	130	140	150	180	200	225	250	275	300	
1"	globe	4.5	4.8	2.6	5.1	9.0	14.0																	
	angle	4.3	5.0	2.5	5.2	9.1	13.5																	
1.5"	globe			1.0	1.4	2.7	4.0	5.8	7.9	10.2	13.0	16.1	19.8											
	angle			0.9	1.3	2.3	3.5	4.9	6.6	9.0	11.2	13.5	16.6											
2"	globe									3.5	4.5	5.4	6.7	8.0	9.3	11.0	12.2	15.7						
	angle									2.8	3.8	4.5	5.5	6.3	7.6	8.7	10.3	13.1						
3"	globe																2.1	3.2	4.0	5.4	6.7	8.1	9.6	
	angle																2.2	3.1	3.8	4.8	5.7	6.9	8.1	

GPM Flow by Size