

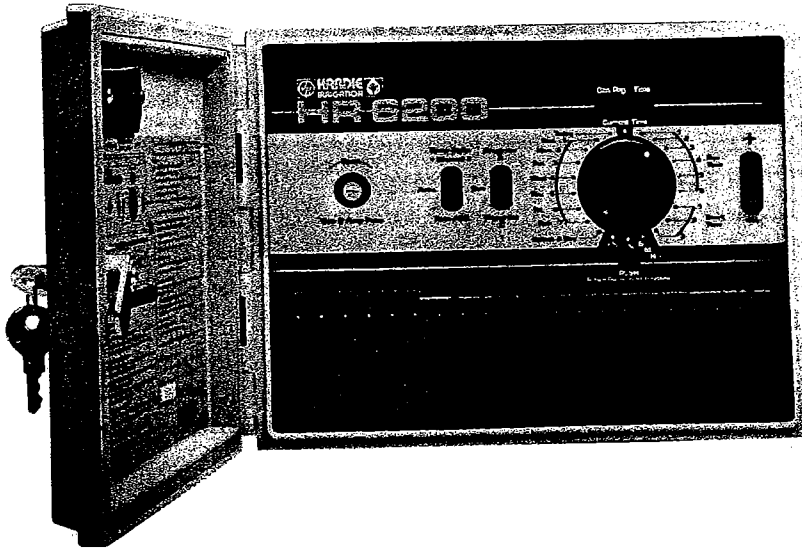

# HR 6200

## Operation Manual



For optional Slave/Master Operation and Remote/Sensor Operation refer to separate Options Instruction Manual (P/N 8452-1).

Station Locations:

- |   |       |   |       |
|---|-------|---|-------|
| 1 | _____ | 4 | _____ |
| 2 | _____ | 5 | _____ |
| 3 | _____ | 6 | _____ |

Date Purchased: \_\_\_\_\_

Date Installed: \_\_\_\_\_

Serial Number: \_\_\_\_\_



Listed  
60T1

# BASIC PROGRAMMING OVERVIEW

## AUTOMATIC OPERATION

|          |  |
|----------|--|
| <b>1</b> | <b>BEFORE YOU BEGIN</b> <ul style="list-style-type: none"><li>• Set <b>Mode Switch</b> to "Auto".</li><li>• Set <b>Program Switch</b> to desired program (A or C).</li><li>• Set <b>Function Dial</b> to "Current Time". Using +/- <b>Rocker</b>, set current time.<br/>NOTE: This controller is based on a 24 hour "military" time (1 p.m. = 13:00).</li></ul>  |
| <b>2</b> | <b>SET THE DAYS YOU WANT TO WATER</b> <ul style="list-style-type: none"><li>• Set <b>Function Dial</b> to "Today". Use +/- <b>Rocker</b> to set today's number. (i.e.) If today is Tuesday, set the number 3 (third day of the week).</li><li>• Set <b>Function Dial</b> to "Sun. -1" and using +/- <b>Rocker</b> set "ON" to water or "OFF" if no watering is to occur. Repeat procedure for days 2-7.</li><li>• <b>IMPORTANT:</b> Set "Select a Day" setting to "OFF" using +/- <b>Rocker</b>. To use the "Select a Day" feature, refer to pages 9 and 11.</li></ul> |
| <b>3</b> | <b>SET THE TIME YOU WANT TO WATER</b> <ul style="list-style-type: none"><li>• Set <b>Function Dial</b> to "Start Time" 1. Program in time 1st watering cycle is to start.</li><li>• Repeat above procedure for 2 and 3. Set unused times to "OFF" (Not 0:00).</li></ul>  |
| <b>4</b> | <b>SET HOW LONG YOU WANT TO WATER</b> <ul style="list-style-type: none"><li>• Set <b>Function Dial</b> to "Run Time" 1 and set watering (run) time.</li><li>• Repeat above procedure for "Stations" 2 through 6. Set unused stations to "00". Finally set <b>Program Switch</b> back to "Run" and <b>Function Dial</b> back to "Current Time".</li><li>• To use "Run Time" increments other than minutes refer to pages 10 and 12.</li></ul>   |

## SEMI AUTO & MANUAL OPERATION

**Manual:** To turn station on for an indefinite period of time: Set **Function Dial** to desired "Run Time" or...

**Semi-Auto:** To start a complete watering cycle: Set **Function Dial** to "Current Time".

**Then:** Set **Mode Switch** to "Manual".

Set **Program Switch** to "Prog. A or C" and then back to "RUN".

Set **Mode Switch** back to "Auto".

Display will flash the station number in operation.

To turn station or cycle off:

Set **Mode Switch** to "Off/Rain" and then back to "Auto".

## FEATURES & SPECIFICATIONS

### FEATURES OF THE CONTROLLER

- Two separate programs with six stations with 3 daily start times per program.
- Each station can water from 1 to 99 minutes. Run Times may also be set as seconds (1-99) or hours (1-99) with one simple step. The hour setting is ideal for drip irrigation.

- Run Times can be increased or decreased by approximately 30% with one simple step.
- A seven day weekly cycle plus a "Select-a-Day" feature which allows watering day intervals from "every other day" up to "every seven days."
- Automatic, semi-automatic or true manual operation.
- Constant "Real Time" read out and station activity display for ease of monitoring.
- "Live Programming" which allows the program to be set or changed during a watering cycle.
- A "Rain" switch which overrides all watering cycles without disturbing the program.
- Battery back-up allows the time to advance and retains your program through a power outage.
- Either an alkaline or a NiCad "rechargeable" battery may be used. A switch provides settings for either battery type.
- A built-in "Fail Safe Program" which will run all six stations for 10 minutes each and every 24 hours at 7:00 a.m. on Prog. A only in the event that you "lose" your program.
- Switchable 50/60 Hz operation mode.
- A handsome, rugged, lockable case with an electrical conduit connection on the power input and provision for free standing pedestal or wall mounting.
- Master valve and/or pump start use.
- **Options:** Please refer to separate "Options Manual" for optional features and use instructions.

## SPECIFICATIONS

- Input = 120 VAC, 60 Hz\*, .5 amps. Note: 220 or 240 VAC, 50 Hz. available, consult factory.
- Output = 24 VAC, at 1.25 amp total max. output; .50 amp per station max.
- Ambient operating temperature range: 32°F to 140°F.
- Battery back-up: One 9 volt alkaline or NiCad (switch selectable). It is factory preset for Alkaline.
- 2 amp "Slo-Blow" fuse # 313-002.

\* Foreign voltage applications may differ.

## WIRING DIAGRAM

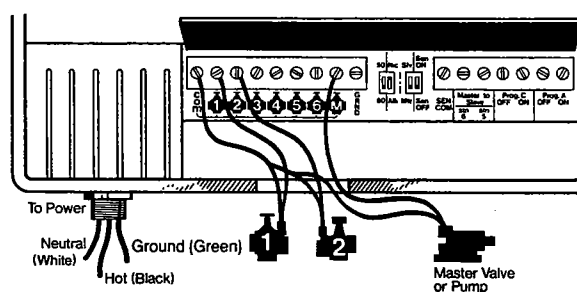

## INSTALLATION INSTRUCTIONS

### 1 Mounting the Controller

The HR 6200 Controller can be mounted in one of two ways:  
 (1) Wall Mount and (2) Pedestal Mount, using the optional pedestal and mounting kit.

## WALL MOUNT

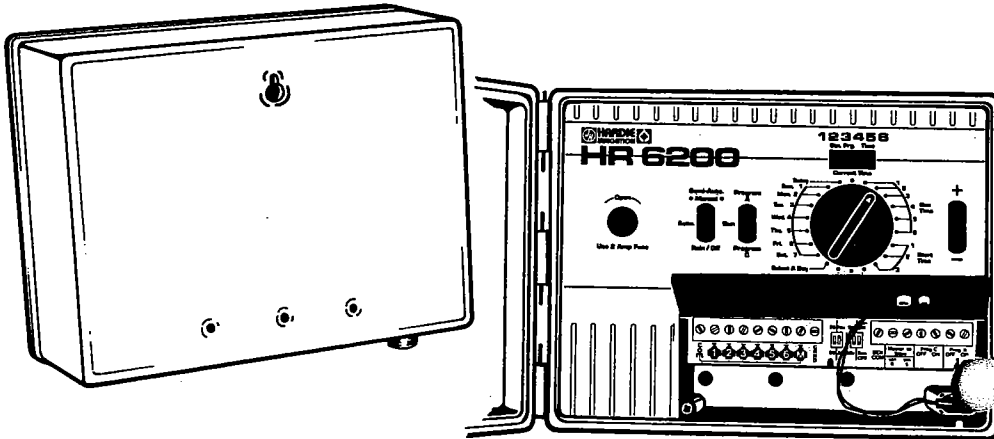

On the back of the controller is a "keyhole" shaped mounting slot as well as 3 mounting holes along the bottom edge. Access to the 3 mounting holes is from the front behind the terminal strip door. **Note:** The holes have thin "Knock-out" partitions to protect the controller internals from the elements should the holes not be utilized. This partition is easily knocked through using a "phillips head" screwdriver.

When attaching to wall studs, use a #10 screw leaving about 1/4" of the head exposed to slip into the "keyhole" slot. To then secure and stabilize the controller, drive additional screws through the bottom mounting holes into the stud or cross bracing.

When attaching the controller to hollow walls, masonry or cinder blocks use the appropriate toggle bolts, masonry shields or compression drive bolts.

For added weather proofing, a silicon bead can be run around between the controller case and the wall after mounting.

## PEDESTAL MOUNT

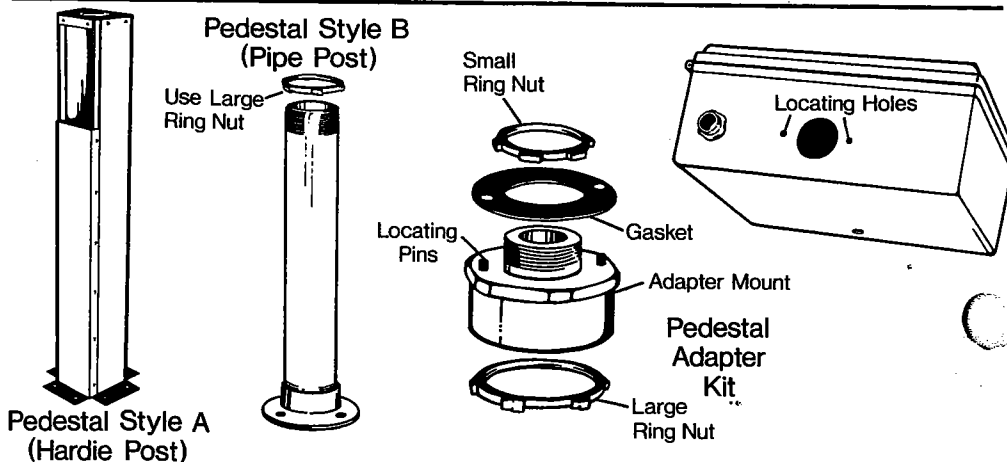

**Note:** The HR 6200 Controller mounting hole pattern is compatible with the Rain Bird Ped-(RC-7A) and PD-7K pedestals and mounting kits.

### To mount to Style "A" (Hardie Pedestal #PED-2):

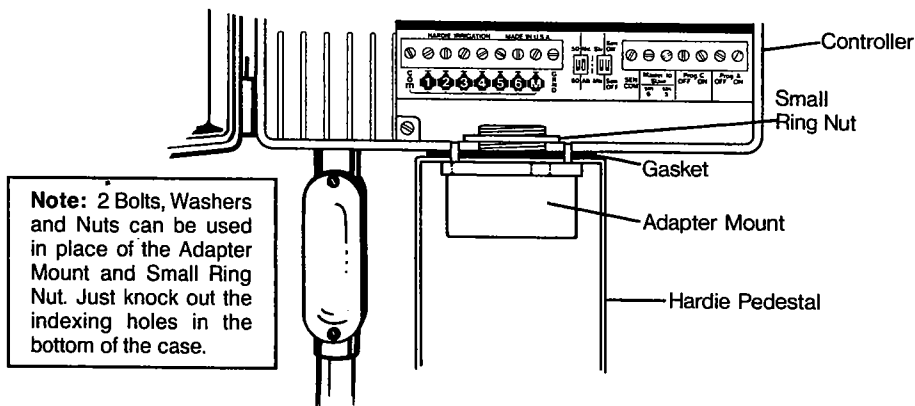

1. Take off pedestal cover plate, open controller terminal strip door
2. Insert "Adapter Mount" up through hole in pedestal. Make sure locating pins align with locating holes.
3. Lay black rubber "Gasket" over the locating pins and threaded portion of "Adapter Mount" that extends through the top of the pedestal.
4. Place the controller on top of the pedestal aligning the locating holes with the locating pins extending through the top of the pedestal.
5. Using the "Small Ring Nut", thread it with the "teeth" down over the "Adapter Mount" threads which should now extend up into the controller. Using a wrench, screw the nut down tight to secure the controller to the pedestal.

### To mount to Style "B" (2" Pipe Post):

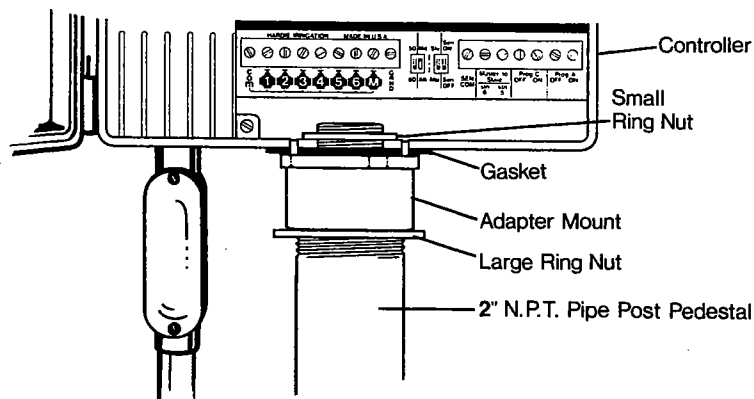

1. Thread the "Large Ring Nut" all the way onto the 2" Pipe Post (schedule 80 or galvanized) with the "teeth" on the ring facing up.
2. Screw the "Adapter Mount" onto the Pipe Post.
3. Once the "Adapter Mount" has been screwed all the way down onto the pipe, position the "Adapter Mount" by backing it out until the locating pins on the mount are positioned in the same plain desired for the controller.

4. Screw the "Large Ring Nut" up on the pipe pedestal until it locks against the bottom of the "Adapter Mount". Tighten it with a wrench.
5. Lay the black rubber "Gasket" over the locating pins on top of the "Adapter Mount".
6. Open the terminal strip door and place the controller on top of the "Adapter Mount" making sure to align the locating pins with the locating holes in the bottom of the controller.
7. Thread the "Small Ring Nut" with the "teeth" down onto the threaded portion of the "Adapter Mount" that extends into the controller. Using a wrench, screw the nut down tight to secure the controller to the pedestal.

## 2 CONNECTING THE POWER LEADS

The HR 6200 Controller has 3 colored 18 gauge power leads extending from the internally mounted transformer down through the conduit hole and fitting.

The leads should be connected to a **120 Volt power source only** according to color as follows:

White Lead = Neutral      Green Lead = Ground      Black Lead = "Hot"

**Note:** The wire gauge used to connect the power to the controller must be of sufficient size to compensate for voltage drop due to electrical resistance in wiring run lengths.

**Note:** Connection methods used should be according to approved National Electrical Code requirements using either wire nuts or solder as required.

The HR 6200 Controller comes standard with an electrical conduit fitting. Most local building and electrical codes require that approved electrical conduit be used when running power to any exterior wall or pedestal mounted controller requiring a 120 Volt power supply.

## 3 CONNECTING THE BATTERY

Using a 9 Volt battery (supplied by the user), connect it to the battery terminal. A molded battery holder compartment is located in the bottom right hand corner of the case. If no battery is used, reconnect the battery terminal to the inside of the terminal strip door.

In case of a power outage, this battery will provide back-up power to retain the program and to advance the clock. **Note:** The battery does not contain enough power to operate the valves. A typical alkaline battery contains enough power for between 6 and 12 hours of power loss. We suggest you change the battery every 3 years.

**Note:** The HR 6200 Controller comes equipped with circuitry enabling the use of either a standard 9 Volt alkaline or rechargeable NiCad battery. A rechargeable NiCad battery should be used in areas that experience frequent or prolonged power outages. A small micro-switch located next to the terminal strip valve connections activates either circuitry. It has 2 positions, "Nic" for NiCad setting and "Alk" for Alkaline setting. *Use the point of a pen or pencil to set the switch.*

We suggest that you first charge a NiCad battery before installing it in the control

## 4 CONNECTING THE VALVES

Route one lead wire from each valve through the large hole at the bottom center of the controller case. Insert each lead under the appropriate screw on the terminal strip. The "common" wire from each valve should be attached to a single "common" wire. Route this common wire through the large hole and connect it to the terminal strip

5

screw labeled "COM".

**NOTE:** This controller is designed for use with 24VAC, 5VA solenoid operated valves. A maximum of two valves per station may be used and no more than 5 valves (or solenoids) should be on at any one time. This includes the master valve if one is being used. Current requirements should not exceed .25 Amp. for each solenoid.

For pedestal mounted controllers route the wires according to that pedestals particular design. For wall mounted controllers, 1/4" (metal or PVC) pipe and a male threaded fitting may be used as a wire conduit.

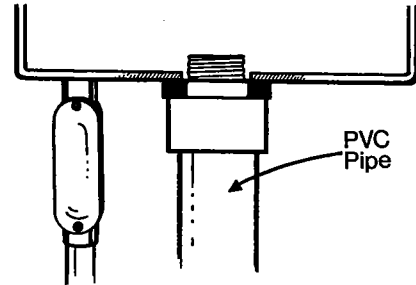

## 5 CONNECTING A MASTER VALVE OR PUMP

To use a master valve which operates throughout the watering run times, simply connect one solenoid lead wire to the terminal strip screw labeled "M", and the remaining lead to the terminal strip screw labeled "COM". **NOTE:** The master valve must be equipped with a 24VAC, 5VA solenoid.

If a pump is to be used, simply connect a relay lead to the same terminal used for the master valve connection. The pump relay should have a nominal coil voltage of 24VAC at .25A maximum.

**CAUTION:** If you are using a pump start and pump start circuit, the "fail safe" program will activate the pump for each of the six stations for 10 minutes each on Prog. A only. If less than six stations are being used, the pump will be running against a "dead head" on each unused station. This can cause a burn-out of the pump.

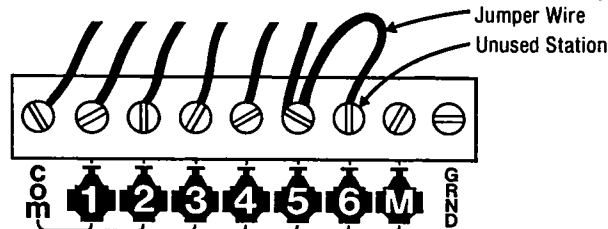

To avoid this simply connect a jumper wire from the unused station terminal over to a station terminal that is being used.

## 6 CHANGING THE FUSE

The HR 6200 comes equipped with a 2 amp "Slo-Blow" fuse mounted to the controller face panel. To check or change the fuse, insert a screwdriver blade into the fuse slot and turn in the direction of the arrow. A simple 1/3 turn will release the spring loaded fuse holder. Only replace the fuse with a fuse #313-002 or equal. To re-insert the fuse holder, push down and turn back approximately 1/3 turn in the opposite direction of the arrow.

## THE DISPLAY

**NOTE:** The controller is based on 24 hour "Military Style" time. Hours 0 (midnight)- 11 are A.M.; hours 12 (noon)- 23 are P.M.

When the program switch is in the "Run" position the display always indicates the current time unless a station or program is on. See illustrations.

After there has been a power outage or after the transformer has just been plugged in, the display will flash as 12:00 p.m. or the current time, depending on how long the outage was. To stop the display from flashing, just press the +/- **Rocker**.

## INFORMATION DISPLAYED WHEN CONTROLLER IS RUNNING

Program Switch in "Run" Position

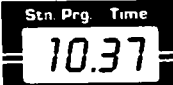
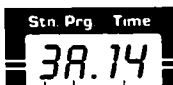
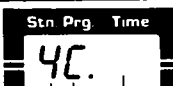
|   |  |
|---|--|
|  | <p><b>Automatic Operation Without Program On.</b><br/>Shows current time with "dot flashing. If whole display is flashing, controller has just been plugged in or there has been a power outage.</p>   |
|  | <p><b>Automatic (or Semi-Auto) Operation With Program On.</b><br/>"Dot" will be flashing.</p> <p style="margin-left: 20px;">Time remaining on that station.<br/>The program that is on. (A or C)<br/>The station that is on.</p> <p><b>NOTE:</b> Located above the display is a row of 6 numbers back lit by LED's. The appropriate number will be illuminated whenever that particular station is on or "running".</p>  |
|  | <p><b>Manual Operation</b><br/>The whole display will be flashing.</p> <p style="margin-left: 20px;">No time remaining will be shown as station will run indefinitely until turned off.<br/>The program that the station was selected from.<br/>The station that is on.</p> <p><b>NOTE:</b> Located above the display is a row of 6 numbers back lit by LED's. The appropriate number will be illuminated whenever that particular station is on or "running".</p> |

## INFORMATION DISPLAYED WHEN PROGRAMMING CONTROLLER

Program Switch in "Prog. A or C" Position

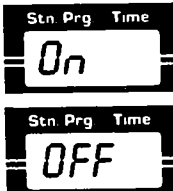
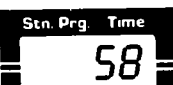
|   |   |
|---|---|
|  | <p><b>"Today" Setting:</b> Displays day numbers "1-7" under Time.</p>   |
|  | <p><b>"Day" Setting: Sun.-1 through Sat.-7 including Select-a-Day.</b> Displays "On" or "Off" under Stn. and Prg.</p> |
|  | <p><b>"Run Time" Settings: Station 1-6.</b> Displays "00-99" in one step increments under Time.</p>                   |



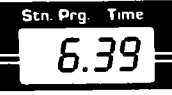

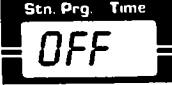
**“Start Time” Settings: Times 1-3.** Displays times “0:00 -23:59” and also displays “Off” if a start time isn’t needed.

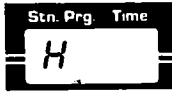

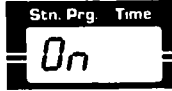
**“Sec., Min., Hrs.” Settings:** Displays “5” (for seconds), “1” (for minutes) or “H” (for hours) under Stn.

**“+% and -% Settings:** Displays “On” or “Off” under Stn. and Prg.

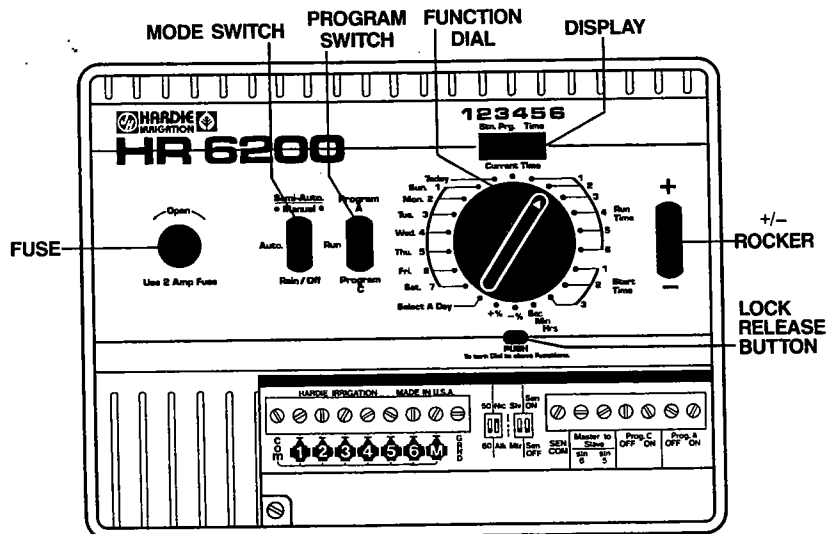
## CONTROL DESCRIPTIONS



**1 THE FUNCTION DIAL**  
 This is used to set, check or change all program information. It is used in conjunction with the +/- Rocker and Program Switch. The Function Dial is also used whenever a station is to be turned on manually. The Function Dial should always be returned to the “Current Time” position after the programming, checking, or manual operation is finished.

**2 THE FUNCTION LOCK RELEASE BUTTON**  
 This button is used to enable the Function Dial to be turned to the +%, -%, Sec., Min., Hrs. settings. Under normal use the Function Dial is “locked out” of these settings to prevent accidental mis-programming. **NOTE:** The Release Button must be pushed at the same time that the Function Dial is being turned to the above settings.

### 3 THE +/- ROCKER

This is used with the **Function Dial** and **Program Switch** to set or change all program information. By tapping either end of the **Rocker**, the information will change by single digits or words (On/Off). The display will show the changes. By holding down either end, the information will change in a two step process. At first, the information will change at a rate of 4 characters per sec., then at a rate of 12 characters per sec.

### 4 THE PROGRAM SWITCH

This switch is used with the **Function Dial** and +/- **Rocker** to set, check or change all program information, and with the **Mode Switch** to operate the controller semi-automatically or manually. Its normal position is at the "Run" setting. In this setting, the controller waters only automatically according to the program schedule. The program *cannot* be checked or changed, or operated manually or semi-automatically in the "Run" setting.

The controller has the capacity of storing and operating two separate programs (called A and C). Use "A" for your main and primary program, and "C" for any alternate programming. To use the dual programming feature, refer to page 12 for further information.

To set, check or change information, the **Program Switch** must be set to either the A or C position (depending upon which program you're using).

When operating a program semi-automatically or manually, set the switch to the appropriate setting (A or C).

### 5 THE MODE SWITCH

This switch has 3 positions:

1. **Semi Auto/Man.** — Used to start the controller semi-automatically or manually.
  - a. **Semi-Automatic:** Turns on a watering cycle regardless of watering days or cycle start times.
  - b. **Manual:** Turns on indefinitely any selected station regardless of programmed information.
2. **Auto** — The normal setting for automatic operation.
3. **Off/Rain** — Used to override any programmed watering cycle, or to stop a cycle or station while it's running. The programmed information is still retained in this setting and the current time keeps running.

---

## FUNCTION DESCRIPTIONS

---

### DAY SETTINGS

These 9 settings control on what days watering is to occur. The watering day schedule can be set in two ways.

- 1) As a 7 day weekly cycle, where watering corresponds to actual days of the week or
- 2) As a "Select-a-Day" cycle where watering occurs at specific intervals regardless of actual days of the week (i.e., every 3rd day).

You may set each program on the same schedule or entirely different schedules (i.e., Program A = Sun. Tues. Fri.; Program C = Every 5th day).

Each day of the week is assigned a number (1-7). All day settings (except "Today") programmed as "Off" or "On". When a day is programmed "Off", no watering will occur in a 24 hour period. When it is programmed "On", watering occurs according to the programmed start and run times. When setting "Today" you will set the number that corresponds to today's actual day (i.e., Tues = 3).

**NOTE:** When using dual programming, if "Select-a-Day" is "OFF" for both programs, setting "Today" is only necessary and possible in Program A. If "Select-A-Day" is "ON" for one or both programs then "Today" can be different for Program A and C.

### START TIME SETTINGS

These 3 settings control at what time of day a watering cycle is to start. Up to 3 different daily start times are available for each program (for a total of 6 start times per day). This, combined with the short run time ability is ideal for newly seeded lawns.

**NOTE:** If a watering cycle is set to start at a late evening hour, the controller will finish out that cycle even if it runs into the next day.

### RUN TIME SETTINGS

These 6 settings control how long each valve (or "station") will water (or "Run"). Each setting corresponds to one of the six valve terminals. (A maximum of 2 valves may be wired to any one terminal.) Each "station" can be set to run from 1-99 minutes in one minute increments. When watering is finished at one station, it will shut off and the next station or valve will come on.

### SEC., MIN., HRS. SETTING

This setting enables the station Run Time to be set as "Seconds" (S), "Minutes" (M), or Hours (H).  
**Note:** Whatever is selected for a particular program (A or C) will apply to all the stations in use at that program, although each program (A or C) can be set to use different time (Sec., Min., Hrs.) settings. The controller comes pre-set to the "Minutes" (M) setting and this setting will suffice for most applications.

The "Seconds" setting is ideal for use in newly seeded or planted applications to prevent run-off by allowing Run Times of up to only 99 seconds. One might use this feature in conjunction with Continuous Cycling operation (see page 14 for more details).

The "Hours" setting is ideal for use in drip irrigation applications although care must be taken in using this setting as Run Times can be set up to 99 hours per station.

### +%, -% SETTINGS

These two settings enable the station Run Times to be increased or decreased by approximately 30% (see chart below) with just one single simple On/Off setting. Use the +% setting to increase watering times during hot spells or dry summer months. Use the -% setting to decrease watering times during cool spells or wet months.

**NOTE:** The original information already programmed into the 6 Run Time settings stays the same with no need to reprogram during or after + or - % use.

**NOTE:** If both +% and -% are accidentally set to "On", the -% setting will prevail.

The chart below shows the amount that time increases or decreases according to various run time lengths.

**NOTE:** Be sure and adjust the Start Times to compensate for longer cycles when using the +30% Budget setting.

| Programmed Run Time | +30% Increases Run Time by: | -30% Decreases Run Time by: |
|---------------------|-----------------------------|-----------------------------|
| 0 - 9               | 0                           | 0                           |
| 10-19               | +3                          | -3                          |
| 20-29               | +6                          | -6                          |
| 30-39               | +9                          | -9                          |
| 40-49               | +12                         | -12                         |
| 50-59               | +15                         | -15                         |
| 60-69               | +18                         | -18                         |
| 70-79               | 99*                         | -21                         |
| 80-89               | 99*                         | -24                         |
| 90-99               | 99*                         | -27                         |

\*For increase, Run Time will only increase to 99.

## AUTOMATIC OPERATION

This controller has the capability of running two separate and totally independent programs called A and C. Use program A for your primary or main watering schedule and program C for areas that require special attention.

**Programming involves just 3 main steps:**

1. **Setting what days you want watering to occur.**
2. **Setting the time(s) you want the watering cycles to start.**
3. **Setting how long you want to water each area (or station to run).**

### 1 Before you begin programming:

1. Set the **Mode Switch** to the "Auto" position.
2. Set the **Program Switch** to the desired program (A or C).
3. Set the **Function Dial** to the "Current Time". Then, using the +/- **Rocker**, set the current time.

**NOTE:** This controller is based on a 24 hour "Military Style" clock. Hours 0 (midnight)-11 are A.M.; hours 12 (noon)-23 are P.M.

#### Reference Chart

| Clock Time | Military Time | Clock Time | Military Time | Clock Time     | Military Time |
|------------|---------------|------------|---------------|----------------|---------------|
| 1:00 A.M.  | 1:00          | 9:00       | 9:00          | 5:00           | 17:00         |
| 2:00       | 2:00          | 10:00      | 10:00         | 6:00           | 18:00         |
| 3:00       | 3:00          | 11:00      | 11:00         | 7:00           | 19:00         |
| 4:00       | 4:00          | 12:00 NOON | 12:00         | 8:00           | 20:00         |
| 5:00       | 5:00          | 1:00 P.M.  | 13:00         | 9:00           | 21:00         |
| 6:00       | 6:00          | 2:00       | 14:00         | 10:00          | 22:00         |
| 7:00       | 7:00          | 3:00       | 15:00         | 11:00          | 23:00         |
| 8:00       | 8:00          | 4:00       | 16:00         | 12:00 MIDNIGHT | 0:00          |

### 2 Setting the Days You Want Watering to Occur

**NOTE:** This controller has the capability of two types of watering cycles: One waters on specific days of the week. The other waters at specific intervals.

**To water on specific days of the week:**

**IMPORTANT:** Set the Select-a-Day setting to "OFF".

1. Each day of the week is assigned a number starting with Sunday = 1 through Saturday = 7.
2. Set the **Function Dial** to "Today". Then using the +/- **Rocker**, set today's number. (i.e., If today is Tuesday, set the number 3.)
3. Set the **Function Dial** to Sun.-1 and set "ON" if watering is to occur on this day or "OFF" if watering is not to occur.
4. Follow the above procedure for days Mon.-2 through Sat.-7.

**To water every "So Many" days:**

**IMPORTANT:** Set the Select-a-Day setting to "ON".

1. Determine the watering interval you wish. (i.e., Every 2nd day, every 3rd day, etc.)
2. Set the **Function Dial** to the corresponding day number and set that day to "ON". (If you want to water every 3rd day, set the Selector to Tue.-3. Ignore the day of week; go by the number only.)
3. Set all other days/numbers to "OFF". If more than one day is set to "On", the Select-a-Day program will go by the smallest numbered day and will disregard all others.
4. Return the **Function Dial** to the Today setting. Determine where in the watering cycle "Today" is and program in that number. (i.e., If watering is to occur every 3rd day, is "Today" day 1, day 2 or day 3 in the 3 day cycle.) The last day of the cycle is when watering occurs.

### 3 Setting the Time(s) You Want the Watering Cycles to "Start"

The controller can start a complete watering cycle up to 3 times for each program during the same day.

1. Set the **Function Dial** to the number 1 beside "Start Time". Using the +/- **Rocker**, program in the time you want your 1st watering cycle to start. Remember: The controller uses a 24 hour "Military Style" clock.
2. Repeat the above procedure for the 2nd and 3rd start times. If you don't need three cycles per day, set the unused start times to "OFF". (Not 0:00, which represents midnight.)

### 4 Set How Long You Want to Water Each Area (or Station)

This is called "Run Time". There are 6 zones or valve "stations" available, with each capable of watering from 1 minute up to 99 minutes (per start time). If you are not using all 6 stations, set any unused stations to read "00".

1. Set the **Function Dial** to the number 1 beside "Run Time" and use the +/- **Rocker** to set the watering (run) time.
2. Repeat the above procedure for "stations" 2 through 6.

The HR 6200 Controller also has the capability of setting the station "Run Times" in time increments of seconds or hours in addition to the standard minute increments.

To select a time increment other than the standard minute, turn the **Function Dial** (while simultaneously pressing the **Lock Release Button**) to the "Sec., Min., Hrs." setting located at the bottom of the dial. Then using the +/- **Rocker**, set the appropriate time symbol (*S*) seconds, (*M*) minutes, (*H*) hours in the display under "Stn".

**NOTE:** Even after all the Run Times have been set, the entire program can be changed by approximately +30% or -30% using the two % settings at the bottom of the dial. This allows for quick programming changes to compensate for seasonal or climate changes. See page 10 for more details.

### 5 Now simply set the Program Switch back to "Run", the Function Dial back to "Current Time" and you're done!

If you desire an additional separate program, set the **Program Switch** to "C" and repeat all of the above programming steps.

## USING DUAL PROGRAMMING

This controller has the capacity for operating two separate watering schedules (or programs). They are designed as "A" and "C". Program your watering schedule for your main lawn or planting areas using Program "A". For areas that require a special watering schedule, use Program "C".

| Program A  | Program C  |
|--|--|
| Main Lawns + Planters<br>Sunny + Dry Area<br>Regular Sprinklers<br>Established Lawns | Special Planting Areas<br>Shady + Cool Areas<br>Drip Irrigation<br>New Lawns |

### Example of Dual Programming

#### EXAMPLE:

Stations 1 through 4 control sprinklers on lawn areas and stations 5 and 6 control drip irrigation on landscaping areas around the front and back of the house. The lawn needs to be watered once a day starting at 6:00 a.m. for 12 minutes. The drip irrigated areas need to be watered Monday, Wednesday, and Friday for 90 minutes starting at 2:00 p.m.

#### TO PROGRAM THIS:

1. Set the current time of day and "Today" according to the program instructions.
2. Move the Program Switch to Program A. For Program A (the sprinkler program) set each day of the week to ON by moving the dial to each day position and set it to ON. Be sure to set Select-a-Day to OFF. Then set the Run Time for each station (1-4) to 12 minutes. Set Stations 5 and 6 to 00 minutes. Turn the dial to Start Time 1 and set to 6 a.m. Start times 2 and 3 should be set to OFF.
3. Move the Program Switch to Program C. For Program C (the drip irrigation program) set Monday, Wednesday, and Friday to On and all other days of the week to OFF. Be sure to set Select-a-Day to OFF. (Note: When using dual programming, if Select-a-Day is "OFF" for both programs, setting "Today" is only necessary and possible in Program A.) Now set the drip irrigated stations Run Times 5 and 6 to 90 minutes. Stations 1 through 4 should be set to 00 minutes. Turn the dial to Start Time 1 and set to 14:00 (2:00 p.m.) and be sure to set Start Times 2 and 3 to OFF. Move the Program Switch to Run and the Mode Switch to Auto and it's all set!

---

### TO CHECK YOUR PROGRAM

---

Simply set the **Program Switch** to the appropriate program to be checked and using the **Function Dial** set it to the function to be checked. **NOTE:** The program cannot be checked if the **Program Switch** is in the "Run" Position.

---

### SEMI-AUTOMATIC OPERATION

---

This type of operation enables a complete programmed watering cycle to be started at any time regardless of the programmed "ON/OFF" days or start times. Use it if an extra watering cycle is desired, say on an especially hot or dry day. Semi-Auto will run through a complete cycle from Station 1 through to Station 6. Upon completion of the cycle, the controller will return to the programmed automatic schedule.

#### To use the Semi-Auto feature:

1. Leave the **Function Dial** in the "Current Time" setting.
2. Set the **Mode Switch** in the "Semi-Auto" position.
3. Set the **Program Switch** to the position that contains the desired watering cycle (Program A or C).
4. Set the **Program Switch** back again to the "Run" position, then simply set the **Mode Switch** back to the "Auto" position.
5. The display will show the appropriate station number, program letter (A or C) and the time remaining on that station.
6. When the cycle is completed, the controller automatically returns to the Automatic program.

---

### MANUAL OPERATION

---

This type of operation enables any station to be operated at any time regardless of the programmed schedule. That specific station will then "Run" indefinitely until it's turned off manually by the user. The controller will then return to the programmed schedule and begin watering again at the next scheduled start time and on the next ON day.

**To turn a station on:**

1. Set the **Function Dial** to the desired station number.
2. Set the **Mode Switch** to "Manual".
3. Set the **Program Switch** to "Program A", then switch it right back to the "Run" position. Then set the **Mode Switch** back to "Auto."
4. The display will now show the station number in operation followed by the letter A for program A. (Although that specific program has no bearing on the manual operation.)

**To turn the station off:**

1. Set the **Mode Switch** to the "Off/Rain" position and then back to the "Auto" position.
2. Set the **Function Dial** back to "Current Time".
3. The station is now off and the display will show the current time. The Controller is back on the programmed schedule again with no loss of time.

**NOTE:** Since the Controller has 2 separate and independent programs (A or C), it has the capability of running one station manually in one program, while at the same time running a complete cycle (auto or semi-auto) in the other program. You can also run 2 stations manually, one in each program.

---

## CONTINUOUS CYCLING

---

Should the need arise to run one cycle continuously say for drip irrigation or for newly planted areas (using run times in seconds), this can be accomplished simply by selecting the appropriate program (A or C) and leaving the **Program Switch** in that position. Then set the **Mode Switch** to the "Semi Auto" position and leave it there. The selected cycle will now run continuously until the Mode Switch and Program Switch are set back to the "Auto" and "Run" positions. **Note:** The display will show the information pertaining to the function dials' position.

---

## WATERING TIPS

---

**How Much to Water:**

During hot weather most lawns require approximately  $\frac{1}{2}$ " of water every other day. For clay soils, hard packed areas or slopes, daily watering of  $\frac{1}{4}$ " is preferred to reduce puddling and run-off. Since weather and soil conditions vary region to region, consult your local nurseryman or landscaper for more specific recommendations.

**How Long to Water:**

To determine how long it takes your particular sprinkler system to discharge the required amount of water, place a number of large flat bottomed pans at different locations around your lawn and turn on your system. After it's run for awhile, measure the water depths in the different pans. This method will give you a pretty good approximation of the time versus discharge for your system.

**When to Water:**

Early morning is the best time of day for watering as evaporation, wind drift and temperatures are minimal. Evening watering is less desirable due to the possibility of mildew and fungus growth as the lawn sits overnight.

---

## OPTIONS

---

**NOTE:** For controllers with optional features, please refer to the separate "Options Instruction Manual", P/N 8452-1.

## TROUBLE SHOOTING

| PROBLEM   | POSSIBLE CAUSE  | CORRECTION   |
|---|---|--|
| Valves don't operate.   | <p>Mode switch in "Rain" position.<br/>Solenoid defective.</p> <p>Loose wire connection.</p> <p>Proper day setting in "Off".</p>  | <p>Set mode switch to "Auto" position.<br/>Test &amp; replace if necessary.</p> <p>Secure wire connections. Check for continuity.</p> <p>Check current day in display. Set Function Dial to correct day and check to see if it is programmed "ON".</p>                       |
| Valves open at strange times.   | <p>Current time of day out of synchronization.</p> <p>Start times need checking.</p> <p>Current time running slow or fast.</p> <p>+% or -% setting in use.</p> <p>Run Times set in wrong mode (Sec., Min., Hrs.).</p> | <p>Check and reset current time.</p> <p>Check and reset first, second or start times.</p> <p>Check 50/60 Hz switch (on terminal strip) and set to appropriate position.</p> <p>Check % setting and reset if necessary.</p> <p>Check setting and reprogram if necessary.</p>  |
| Program won't display.  | <p>No power at source.</p> <p>No power to controller.</p> <p>In wrong mode.</p> <p>Controller is in watering cycle.</p> <p>Blown fuse.</p>  | <p>Check current, fuse, or circuit breaker.</p> <p>Check wiring and connections.</p> <p>Program switch must be in "Run" mode.</p> <p>Check or change program when controller is out of watering cycle.</p> <p>Replace fuse and check valve wiring or solenoid for short.</p> |
| Display not reading correctly after a power-outage or after being plugged in. | <p>Back-up battery is weak or no battery is being used.</p>   | <p>Cut power and battery for 1 minute. Then replace battery, restore power and reprogram.</p>  |
| Waters on a day when not scheduled.   | <p>Individual day or Select-a-day schedule improperly programmed.</p>   | <p>Reprogram, referring to Control Descriptions and Instructions for correct procedure.</p>  |
| Current time of day is wrong time.  | <p>Power outage occurred with no batteries or dead batteries used in the controller.</p> <p>50/60 Hz switch in wrong position.</p>  | <p>Reset current time of day. If upon checking watering times they are different than previously programmed, reprogram controller. and replace batteries.</p> <p>Check switch (on terminal strip) and set to correct position (using pen or pencil point).</p>               |

