

Irritrol®

SYSTEMS

446PR / 446PRI IRRIGATION CONTROLLER

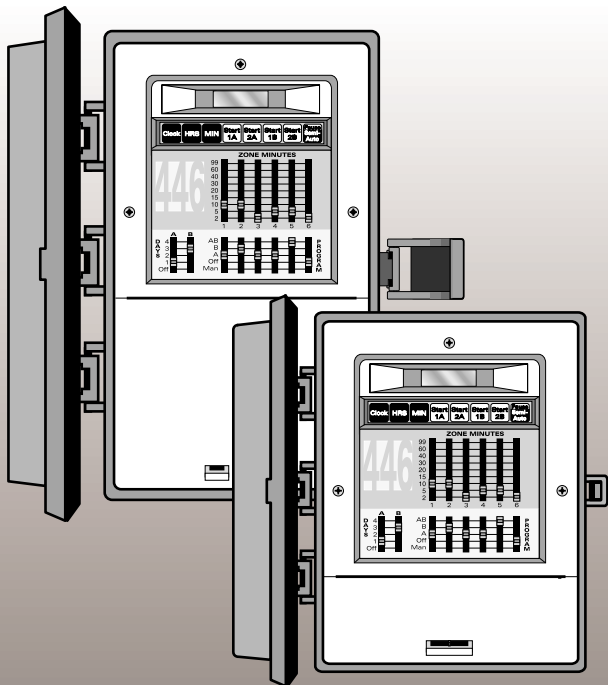

INSTALLATION AND OPERATING GUIDE

FEATURES

- **SIX ZONE CONTROL:** Turns up to six sprinkler valves on and off automatically in sequence.
- **DUAL PROGRAMMING:** Allows you to water your lawn and landscape on separate schedules.
- **EASY AT-A-GLANCE SETTINGS:** Makes it simple to set watering lengths and days.
- **MULTIPLE START TIMES:** Lets you water up to four times per day - ideal for new lawns.
- **EXTENDED WATERING PERIODS:** Allows you to water up to 99 minutes a day per zone.
- **PAUSE FUNCTION:** Makes it easy to interrupt watering cycles for yard activities.
- **MANUAL OPERATING MODE:** Allows you to water manually when an automatic watering cycle is not in progress.
- **ELECTRONIC CIRCUIT BREAKER:** Prevents controller shut-down in the case of a short circuit in a valve; diagnostic feature displays malfunctioning valve number for easy trouble-shooting.
- **MASTER VALVE/PUMP START CONNECTION:** Automatically turns a pump or a master valve on and off. (Requires a pump start relay, Model SR-1, if used with a pump).

TO USE YOUR NEW CONTROLLER MOST EFFECTIVELY, PLEASE READ THIS MANUAL CAREFULLY AND REFER TO THE MANUAL IF ANY DIFFICULTIES ARISE.

NOTE: For areas which are vulnerable to lightning strikes, or transient electrical surges caused by unstable power supply, consult your local supplier or contractor for additional protection devices which may be required.

TABLE OF CONTENTS

Controller Components	4–5
Installation Procedures	
• Selecting The Location	6
• Mounting The Controller	6–7
• Connecting The Valve Wires	7–8
• Connecting A Pump Start Relay Or Master Valve	8
• Connecting The Power Source (Outdoor Models)	9–10
• Connecting The Battery	10
Planning Your Watering Schedule	
• Guidelines For Watering	11
• Selecting The Right Program	11
• Filling In The Watering Schedule Form	11
• Watering Schedule Forms	12
Programming Steps	
• Setting Correct Time	13
• Assigning Zones To A Program	13
• Setting Program Start Times	14–15
• Setting Zone Run Time	15
• Setting Program Cycle Days	15
Manual And Semi-Auto Operation	
• Manual Operation	16
• Semi-Auto Operation	16
Controller Shut-down / Circuit Breaker	
• Controller Shut-Down	17
• Electronic Circuit Breaker	17
Voltage Specifications	18
Troubleshooting	18
Electro-Magnetic Compatibility	19

CONTROLLER COMPONENTS

Figure 1

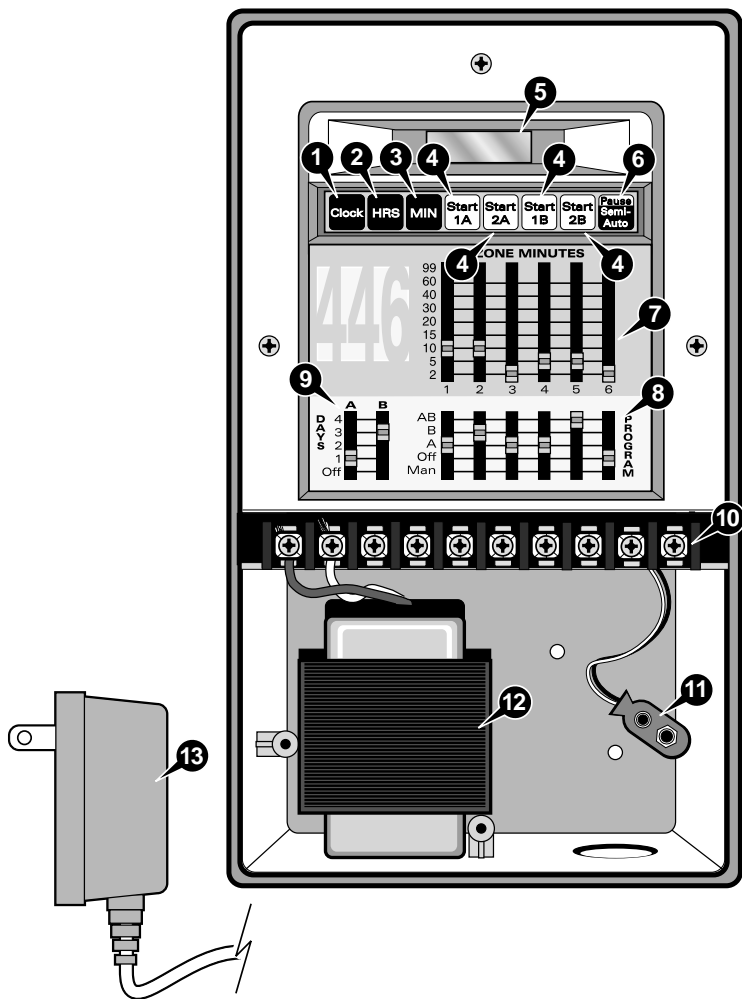

CONTROLLER COMPONENTS

- 1 CLOCK - DAY NOW KEY**
Allows you to set the current time and day
- 2 HOURS KEY**
Allows you to set the correct hour for the current time as well as the hour for the desired start times.
- 3 MINUTES KEY**
Allows you to set the correct minute for the current time as well as the minute for the desired start times.
- 4 START KEYS**
Enable you to set the start times of each programs (two start times for program **A** and two for program **B**).
- 5 CONTROLLER DISPLAY**
It displays the current time or the zone number being watered with its watering run time when a program is in progress. It also indicates programming errors and short circuits when detected.
- 6 PAUSE - SEMI-AUTO KEY**
Temporarily interrupts a watering cycle in progress or allows you to start a semi-automatic watering cycle
- 7 ZONE MINUTES SWITCHES**
Allows you to select the watering time duration for each zone from **2–99** minutes
- 8 PROGRAM SWITCHES**
Allows you to designate each zone to program (**A**, **B**, or **AB**).
- 9 DAYS SWITCHES**
Allows you to set the day interval for each watering program.
- 10 TERMINAL SCREWS**
Terminal connections for the power source, zone 1–6, pump start/master valve and valve common.
- 11 BATTERY CONNECTOR**
Connects a 9 volt battery to retain stored watering cycle programs in case of a power failure.
- 12 INTERNAL TRANSFORMER (Outdoor models)**
Enables the controller to connect to a 120 V a.c., 60 Hz source (220/240 V a.c., 50 Hz source for the international units).
- 13 PLUG-IN TRANSFORMER (Indoor Models)**
Supplied with 120 V a.c., 60 Hz.

INSTALLATION PROCEDURE

⚠ WARNING: All electrical components must meet applicable national and local electrical codes including installation by qualified personnel. These codes may require an external junction box mounted on the transformer 1/2" nipple and a means, in the fixed wiring, of disconnecting AC power having a contact separation of at least 0.120" (3 mm) in the line and neutral poles. Ensure the AC power source is OFF prior to connecting to the controller. The wire used for connection to the controller must have insulation rated at 105° C minimum.

STEP 1 : Selecting The Location

For the 446 PRI (indoor models), choose an indoor location near a standard 120 V a.c. wall outlet. Install the controller in an area protected from weather, such as a garage, and within 5' (1.5 m) of a grounded electrical outlet. The 446 PR (outdoor model) can be installed almost anywhere, but avoid exposure to direct sun or irrigation spray. The controller must be powered by a well grounded AC circuit.

⚠ CAUTION: Do not place the controller where temperatures may exceed 60° Centigrade (140° Fahrenheit) or on a circuit controlled by a switch or on the same circuit with a high power user (refrigerator, air conditioner, garage door opener, etc.). Malfunctions may result.

STEP 2 : Mounting 446 PR Controller (Outdoor Model)

1. Mount the hanger kit (1 hanger and 1 screw) on the top rear of the controller.
2. Position the controller on the wall slightly below eye level. Mark the mounting screw location at the top of the hanger's keyhole slot.
3. Install a #8 mounting screw into the wall at the marked location leaving the screw head about 1/4" (6 mm) out from the wall.
4. Remove the screw from the controller's bottom panel. Pull the panel out to access the two bottom screw holes.
5. Hang the controller on the mounting screw while making sure the screw head is secured at the top of the keyhole slot. Install the two bottom mounting screws, then tighten the top keyhole screw securely.
6. Replace the lower bottom to the controller.

INSTALLATION PROCEDURE

Mounting 446 PRI Controller (Indoor Model)

1. Install a #8 mounting screw at eye level on the wall, leaving the screw head extended 1/4" (6 mm) out from the wall.
2. Hang the controller on the mounting screw. Make sure the screw head is secured at the top of the keyhole slot. See **Figure 2**.
3. Install the lower mounting screws.
4. Replace the controller's bottom panel.

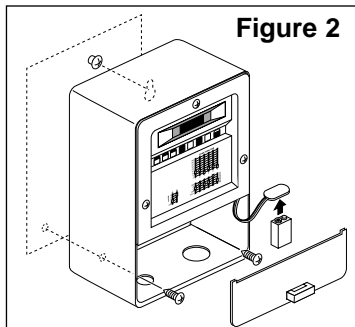

Figure 2

STEP 3 : Connecting The Valve Wires

⚠ CAUTION: The power transformer is protected by an electronic circuit breaker. Do not connect a combination of valves requiring an inrush current above 1 Amp at 24 V a.c. to one zone terminal.

1. Route valve control wires between the valves and the controller.

Note: An 18 AWG (0.75 mm) multi-wire cable is recommended. This cable is insulated for direct burial and color coded to simplify installation.

2. Attach the white color-coded wire to one of the wires from each valve solenoid (either solenoid wire can be used). The white wire is designated as the valve common wire.

(continued to the next page)

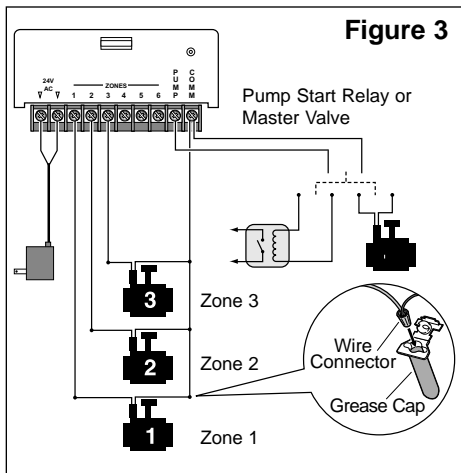

Figure 3

INSTALLATION PROCEDURE

3. Attach a separate color-coded wire to the remaining wire from each valve solenoid. Make a note of the wire color used for each valve and the watering zone it controls. You will need this information when connecting the valve wires to the controller.
4. Secure all wire splices using a twist-on wire connectors. To prevent corrosion and possible short circuit, use a grease cap or similar waterproofing method to insulate each wire splice connection. See **Figure 3** insert on page 7.
5. Remove the controller's bottom panel and route the valve cable into the controller through the conduit opening at the base of the cabinet. Strip back the wire insulation, about 1/2" (13 mm), from all cable wires to be connected.

Note: The identification label for each of the terminal screws are located at the backside of the controller's bottom plastic panel.

6. Secure the valve common wire to the terminal labeled **COMM**. Connect the individual valve wires to the valve terminals labeled **1–6** in the order you wish the valve zones to operate.
7. Replace the controller's bottom panel and test each valve for proper operation using the **MAN** option under the **PROGRAM** switches after connecting the AC power source.

STEP 4 : Connecting A Pump Start Relay Or Master Valve

When a pump relay is required to be operated by the controller, a compatible relay must be used. The relay coil will be connected to the **PUMP** terminal. Refer to the Voltage Specification on page 19 of this Installation Guide for power requirements. The relay contacts will be connected to the pump start terminals and must be rated for use with that particular pump.

⚠ CAUTION: To prevent controller damage, ensure the relay's current draw does not exceed 1A. Do not connect the controller directly to the pump starter. The pump start relay must be installed at least 5' (1.5 m) away from the controller.

1. Route a twisted pair cable from the pump relay or the master valve into the controller housing through the conduit opening.
2. Connect one of the wires to the **COMM** terminal and the remaining wire to the terminal labeled **PUMP**.
3. Test for proper operation after connecting the AC power source.

INSTALLATION PROCEDURE

STEP 5 : Connecting The Power Source

The outdoor controller model has a built-in transformer which must be connected to a grounded AC power source. Refer to the **POWER SPECIFICATIONS** on page 18 for the proper power requirements. Electrical conduit and adapters are not supplied with the controller but are generally required. Check local building codes and install conduit accordingly.

⚠ CAUTION: Before wiring the internal transformer, switch off power at the source. Do not link two or more controllers via a common transformer or common wire.

PR (Outdoor Model)

1. Verify that the power has been turned off at the power source by using an appropriate AC voltage meter.
2. For the power wire connection, install a 3/4" (19 mm) NPT threaded conduit to the transformer assembly nipple. Install electrical conduit from the conduit body to the AC power source circuit breaker panel.

Note: Figure 4 applies to 120 V a.c., 60 Hz models only. For international models, connect in accordance to local and national electrical codes.

3. Route a three wire cable through the conduit and out from the conduit body.
4. Splice the mating wires. Connect and insulate the wires with proper size wire connectors. See **Figure 4**.
5. Close and secure the conduit cover.
6. Apply power to the controller and test each valve for proper operation using the **MAN** option under the **PROGRAM** switches.

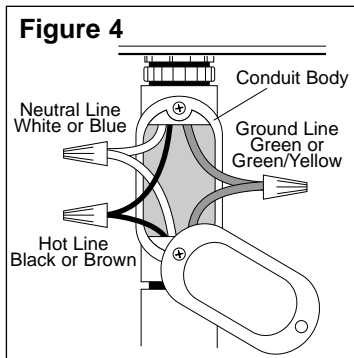

INSTALLATION PROCEDURE

PRI (Indoor Model)

Note: The plug-in transformer is supplied with the 120 V a.c., 60 Hz indoor controller models only. See page 18 for the controller's proper power specifications.

⚠ CAUTION: Make sure the transformer is unplugged during installation.

1. Lift out the the controller's bottom plastic panel.
2. Route the plug-in transformer cable into the controller through the provided conduit opening at the base of the cabinet.
3. Attach the transformer cable to the 24 V a.c. terminals. Make sure the transformer leads do not make contact.
4. Replace the bottom panel of the controller.
5. Plug in the transformer to apply power to the controller and test each valve for proper operation using the **MAN** option under the **PROGRAM** switches.

STEP 6 : Connecting The Battery

1. Remove the bottom panel of the controller.
2. Connect a 9 volt alkaline battery (not supplied) to the battery connector found inside the wiring compartment. Installing a battery enables the controller to retain watering programs stored in the controller's memory during power failures. See **Figure 2** on page 7.
3. Replace the bottom panel.

⚠ CAUTION: Batteries contain hazardous materials. Always handle and discard batteries properly in accordance with the battery manufacturer's recommendations.

PLANNING YOUR WATERING SCHEDULE

Guidelines For Watering

There are several factors to be considered when deciding when and how long to water. For example, the soil type (i.e. clay, loam, etc.), the part of the landscape being watered, climate conditions and the type of sprinklers being used. Because of these variables, we cannot provide an exact schedule to follow, but here are some general watering guidelines to help you get started.

- Water early in the morning, one to two hours before sunrise. You will have the best water pressure at this time and the water can soak into the plant root zone while evaporation is minimal. Watering during mid-day or in the evening may cause plant damage or mildew.
- For new lawns where frequent watering is required, take advantage of the multiple start time feature of the 446 PR/PRI controller. Each watering program cycle can be initiated twice a day.
- If under- or over-watering signs are observed, adjust program immediately.

Select The Right Program

On the following pages are some guidelines for planning your automatic watering programs. We recommend taking a few moments to review this information and filling in the watering schedule form provided.

Filling In The Watering Schedule Form

It is always helpful to plan your watering schedule on paper before beginning the programming steps. When completed, you will have a guide to use during programming, and a record of your watering schedule which can be kept with the controller for future reference.

Here are the information you will need to program your controller for automatic operation:

- **Location** - Identify the location of each valve's watering zone number.
- **Zone Run Time** - Indicate the amount of watering run time required for each zone (2–99 minutes).
- **Watering day schedule**
Identify the watering day schedule for each program (everyday, every other day, every third day or every fourth day interval).
- **Program Start Times** Indicate the time of day you wish each watering program to start.

WATERING SCHEDULE FORMS

Watering Schedule Form		PROGRAM A	PROGRAM B
WATERING DAY SCHEDULE	Everyday <input type="checkbox"/> Off <input type="checkbox"/>		Everyday <input type="checkbox"/> Off <input type="checkbox"/>
	Every 2nd, 3rd or 4th Day	2nd <input type="checkbox"/> 3rd <input type="checkbox"/> 4th <input type="checkbox"/>	2nd <input type="checkbox"/> 3rd <input type="checkbox"/> 4th <input type="checkbox"/>
STATION	LOCATION	STATION RUN TIME	STATION RUN TIME
1			
2			
3			
4			
5			
6			
PROGRAM START TIMES		1	1
		2	2

Watering Schedule Form		PROGRAM A	PROGRAM B
WATERING DAY SCHEDULE	Everyday <input type="checkbox"/> Off <input type="checkbox"/>		Everyday <input type="checkbox"/> Off <input type="checkbox"/>
	Every 2nd, 3rd or 4th Day	2nd <input type="checkbox"/> 3rd <input type="checkbox"/> 4th <input type="checkbox"/>	2nd <input type="checkbox"/> 3rd <input type="checkbox"/> 4th <input type="checkbox"/>
STATION	LOCATION	STATION RUN TIME	STATION RUN TIME
1			
2			
3			
4			
5			
6			
PROGRAM START TIMES		1	1
		2	2

PROGRAMMING STEPS

STEP 1 : Setting The Correct Time

The controller's clock features a 12-hour format where **1200P** represents 12:00 p.m. (noon) and **1200A** represents 12:00 a.m. (midnight). When power is first applied, the controller automatically resets the day and time to **Day 1** and **400P**.

1. Press the **Clock** key to place the controller in time setting mode.
2. Advance the hour digit by holding down or by pressing the **HRS** key repeatedly until the correct hour and **A** (a.m.) or **P** (p.m.) is displayed.
3. Advance the minute digit by holding down or by pressing the **MIN** key repeatedly until the current minute is displayed.
4. Once the current time is set, the procedure is completed. If no additional key is pressed within 15 seconds, the controller will revert back to time mode.

STEP 2 : Assigning Zones To A Program

The controller provides several options that allow simple, flexible programming. The dual program feature provides the ability to water individual areas of the yard on separate schedules.

A typical example of how these programs might be used would be to assign all lawn zones to program **A** and all shrub zones to program **B**. Since watering demands are generally quite different for lawns and shrubs, dual programming enables watering days and start times to be tailored specifically for each type of plant material.

1. Select each zone's watering program by simply moving each zone's program switch to **A** for program A, **B** for program B or **AB** for the combination of program **A** and **B**.
2. To disable a zone, simply move its designated zone switch into the **OFF** position.

Note: If a zone switch is placed in the **AB** position, the zone will start watering at every start time programmed in both **A** and **B**. Unused zones should be placed in the **OFF** position.

PROGRAMMING STEPS

STEP 3 : Setting Program Start Times

A program start time is the designated time when the programmed automatic watering cycle begins. Sometimes it is necessary to run a program more than once within the same day, for example, when growing a new lawn. The controller has the ability to start each program twice a day.

Refer to the following guidelines when programming the start times:

- A start time (**START A** or **START B**) activates a watering **cycle**, not an individual zone.
- A program requires only one start time to operate automatically.
- When a program starts, each zone assigned to the program will water in numerical order, **one at a time** until its designated run time.
- Enough time should be provided between program start times to allow all zones assigned to the program to be watered. If a start time produces a watering cycle that runs beyond the next start time, the controller will delay the next start time(s) to allow completion of the previous watering cycle.
- If a start time produces a watering cycle that runs past midnight, any remaining start times scheduled to start before midnight will be cancelled.
- Start times begin according to the time they are programmed to water, and not by the order at which they were programmed. For example, the first start time programmed on **START A** may actually be the last watering time to occur if it is programmed to water at 11:00 p.m., and the last start time programmed on **START A** may actually be the first to occur if programmed to water at 5:00 a.m.

To Set Start Time

1. Press **START 1A** key. The display will show the current start time programmed in **START 1A** or **OFF** if it has been disabled.
2. Hold down or repeatedly press the **HRS** key to advance the start time hour until the desired hour and **A** (a.m.) or **P** (p.m.) are displayed.
3. Hold down or repeatedly press the **MIN** key to advance the minute until the desired minute is displayed.
4. Repeat the process to program the other **START** times as needed.
5. To disable a start time, advance the start time hour until **OFF** is displayed. **OFF** comes after **1100P**.
6. Press the **Clock** key to return the controller back to time mode.

NOTE: Once you have pressed a **START** key, you must press the **HRS** or **MIN** key within 10 seconds. Otherwise, the controller will revert back to time mode

PROGRAMMING STEPS

STEP 4 : Setting The Zone Run Time

The zone run time is the duration the zone will water during a watering cycle. Each of the six zones can be set to run at different duration between 2–99 minutes.

1. To set each zone's run time, simply align each **ZONE MINUTE** switch to the desired run time along the time indicator. Do not place the switch between the indicated run times. During watering, the zone number and its current run time will appear on the display

IMPORTANT: Make sure the switches are placed on the minute marks and not between the marks. Improper run time may occur.

STEP 5 : Setting Program Cycle Days

The **DAYS** switch sets the day interval for the program to cycle.

1. Move the **DAYS** switch for each program (**A** or **B**) to the desired watering interval. Slide the switch to **4** for every 4th day, **3** for every 3rd day, **2** for every other day or **1** for everyday.

For example, if the **DAYS** switch on program **A** is set to **4**, the controller will water every fourth day. After the switch is moved to **4**, the display shows **day 1**, which indicates a watering day. This means that program **A** will water today if the watering time has not been missed.

By pressing the **HRS** key while the display shows **day 1**, you can change **day 1** to one of the following options:

day 0 - No more watering today.

day 1 - Water today.

day 2 - Water tomorrow.

day 3 - Water the day after tomorrow

day 4 - Water on the 4th day.

This option can be used when both programs are set to the same watering cycle interval so program **A** will water on a different day than program **B**.

To return the controller into time mode, press the **Clock** key or wait 10 seconds after the last keystroke.

2. Move the switch to **OFF** if a program is unused.

Note: The controller counts down from the day interval set to the designated active watering day. Day changeover occurs at 1200P.

Step 1 : Manual Operation

1. To water your yard manually, move the **PROGRAM** switch of the zone you wish to water to **MAN**. The controller will allow only one zone at any given time to be watered manually. If more than one zone switch is placed in the **MAN** position, only the lowest zone number will water. When the switch is moved off the **MAN** position, the second lowest zone number set to **MAN** will start to water. The **MAN** setting will override any automatic watering cycle including any watering cycle in progress.

NOTE: When a zone switch is placed in **MAN**, the controller will water continuously until the switch is moved.

Step 2 : Semi-Auto Operation

1. Semi-auto operation can be initiated by pressing the **PAUSE - SEMI-AUTO** key. The controller will energize all the zones, one zone at a time, starting from zone **1** until zone **6**. The controller will skip any zones that are disabled (zones placed in the **OFF** position within the **PROGRAM** switches). The zones will continue to water until their designated time duration expires, then the next zone in sequence will start. The controller will revert back to the time mode after watering the last zone in the sequence.
2. Pressing the **Min** key will advance the watering to the next zone in sequence.

To pause the cycle, press the **PAUSE - SEMI-AUTO** key once. The display will alternately flash "**PAUSE**" as well as the station number and run time. To resume the watering cycle, press **PAUSE - SEMI-AUTO** key again and the station run time countdown will continue.

3. To exit the semi-auto operation, first pause the operation by pressing the **PAUSE - SEMI-AUTO** key. After pausing the semi-auto operation, press the **CLOCK** key followed by the **PAUSE - SEMI-AUTO** key to terminate the operation. When terminated successfully, **OFF** will be displayed. Pressing the **MIN** key repeatedly until the time mode is displayed will also exit the semi-auto operation.

CONTROLLER SHUT-DOWN / CIRCUIT BREAKER

Controller Shut-Down

When automatic watering is not needed, you can prevent the programmed watering cycles from starting by moving the **DAYS** switches into the **OFF** position.

NOTE: Manual watering is still possible even when the **DAYS** switches are in the **OFF** position.

Electronic Circuit Breaker

The 446 PR/PRI controller is equipped with an electronic circuit breaker that can detect short circuits in the valve zone terminals. If the controller detects a short circuit, the shorted valve will automatically turn off. The display will then alternately flash **FUS** with the shorted zone number. The controller will continue to automatically water the remaining zones in the current watering cycle as well as execute the next watering cycles.

After repairing the short circuit, press the **CLOCK** or any of the **START** keys to return the controller to its current operating mode.

VOLTAGE SPECIFICATION / TROUBLESHOOTING

Voltage Specifications

	Power Input	Station Output	Pump Output
Domestic Models	120 V a.c., 60 Hz., 35W	24 V a.c., 1 VA	24 V a.c., 9 VA max.
International Models	250 V a.c., 50 Hz., 18W	24 V a.c., 1 VA	24 V a.c., 9 VA max.

Troubleshooting

Problem	Possible Cause
One or more valves do not operate.	<ol style="list-style-type: none">1. Faulty solenoid.2. Poor wire connection.3. Possible break in wire.4. Valve flow stem is screwed down too far.
Display is stuck on a zone and FUS is flashing on the display.	<ol style="list-style-type: none">1. Faulty solenoid.2. Shorted or poor wire connection.
Continuous loss of time.	<ol style="list-style-type: none">1. No battery.2. Weak or bad battery.3. Controller is on an electrical circuit controlled by a switch.4. Controller is on the same circuit as a high power user (refrigerator, air conditioner, etc.).
Zones turn on when they are NOT programmed to start.	<ol style="list-style-type: none">1. Start times and the total combined zone run times have overlapped.
The clock has the correct time and the zones appear to be functioning properly, but none of the valves are on.	<ol style="list-style-type: none">1. One or more zone switches are in the OFF position.2. The common wire is not hooked up.3. Valve flow stem is screwed down too far.
Zone does not shut OFF .	<ol style="list-style-type: none">1. Zone switch is in MAN.2. Faulty valve.3. Particles of dirt or debris are preventing proper valve operation.

ELECTROMAGNETIC COMPATIBILITY

Domestic: This equipment has been tested and found to comply with the limits for a Class B digital device, pursuant to Part 15 of the FCC Rules. These limits are designed to provide reasonable protection against harmful interference in a residential installation. This equipment generates, uses and can radiate radio frequency energy and, if not installed and used in accordance with the instructions, may cause harmful interference to radio communications. However, there is no guarantee that interference will not occur in a particular installation. If this equipment does harmful interference to radio or television reception, which can be determined by turning the equipment off and on, the user is encouraged to try to correct the interference by one or more of the following measures:

1. Reorient or relocate the receiving antenna.
2. Increase the separation between the equipment and receiver.
3. Connect the equipment into an outlet on a circuit different from that to which the receiver is connected.
4. Consult the dealer or an experienced radio/TV technician for help.

The user may find the following booklet prepared by the Federal Communications Commission helpful:

“How To Identify and Resolve Radio-TV Interference Problems”. This booklet is available from the U.S. Government Printing Office, Washington, DC 20402. Stock No. 004-000-00345-4.

International: This is a CISPR 22 Class B product.

**Irritrol Systems offers an entire family of products
for commercial and residential applications:**

Controllers and Controller Accessories

Valves and Valve Accessories

Rotors, Spray heads, and Nozzles



U.S.A.:
P.O. Box 489
Riverside, California 92502
Tel: (909) 785-3623
(800) 634-8873

Australia:
Irritrol Systems PTY Ltd.
53 Howards Road
Beverley SA 5009
Tel: (08) 8300 3633

Europa:
Irritrol Systems Europe s.p.a.
Via dell'Artigianato, 1/3-Loc Prato della Corta
00065 Fiano Romano (Roma), Italia
Tel: (39) 0765 455201